



Energy Related Products

SUPER DC INVERTER SERIES

Service Manual



Part 1 General Information 1

Part 2 Indoor Units 5

Part 3 Outdoor Units 56

Part 4 Installation 69

Part 5 Electrical Control System 96



Caution: Risk of fire/flammable materials

※The specifications, designs, and information in this book are subject to change without notice for product improvement.

Part 1

General Information

1. Model List	2
2. External Appearance	3
2.1 Indoor Units.....	3
2.2 Outdoor Units.....	3
3. Nomenclature	4

1. Model List

1.1 Indoor Units

(capacity multiplied by 1000Btu/h)

Type	Function	12	18	24	30	36	42	48	60
Compact Cassette	Cooling and heating	●	●	/	/	/	/	/	/
Super slim cassette	Cooling and heating	/	/	●	/	●	/	●	●
A6 Duct	Cooling and heating	●	●	●	●	●	●	●	●
Ceiling-floor	Cooling and heating	/	●	●	/	●	/	●	●

1.2 Outdoor Units

Universal Outdoor unit Model	Compressor type	Compressor Brand	Matched indoor units
38QUS012D8S*	Rotary	GMCC	42QTD012D8S* 42QSS012D8S*
38QUS018D8S*	Rotary	GMCC	42QTD018D8S* 42QSS018D8S* 42QZL018D8S*
38QUS018R8S*	Rotary	GMCC	42QTD018R8S* 42QSS018R8S* 42QZL018R8S*
38QUS024R8S*	Rotary	GMCC	42QTD024R8S* 42QSS024R8S* 42QZL024R8S*
38QUS030R8S*	Rotary	GMCC	42QSS030R8S*
38QUS036R8S*	Rotary	GMCC	42QTD036R8S* 42QSS036R8S* 42QZL036R8S*
38QUS036R8T*	Rotary	GMCC	42QSS036R8S*
38QUS042R8S*	Rotary	GMCC	42QSS042R8S*
38QUS048R8T*	Rotary	GMCC	42QTD048R8S* 42QSS048R8S* 42QZL048R8S*
38QUS060R8T*	Rotary	GMCC	42QTD060R8S* 42QSS060R8S* 42QZL060R8S*

2. External Appearance

2.1 Indoor Units

Compact cassette



Super Slim Cassette



Ducted



Ceiling-Floor



2.2 Outdoor Units



Single fan outdoor unit



Double fan outdoor unit

3. Nomenclature

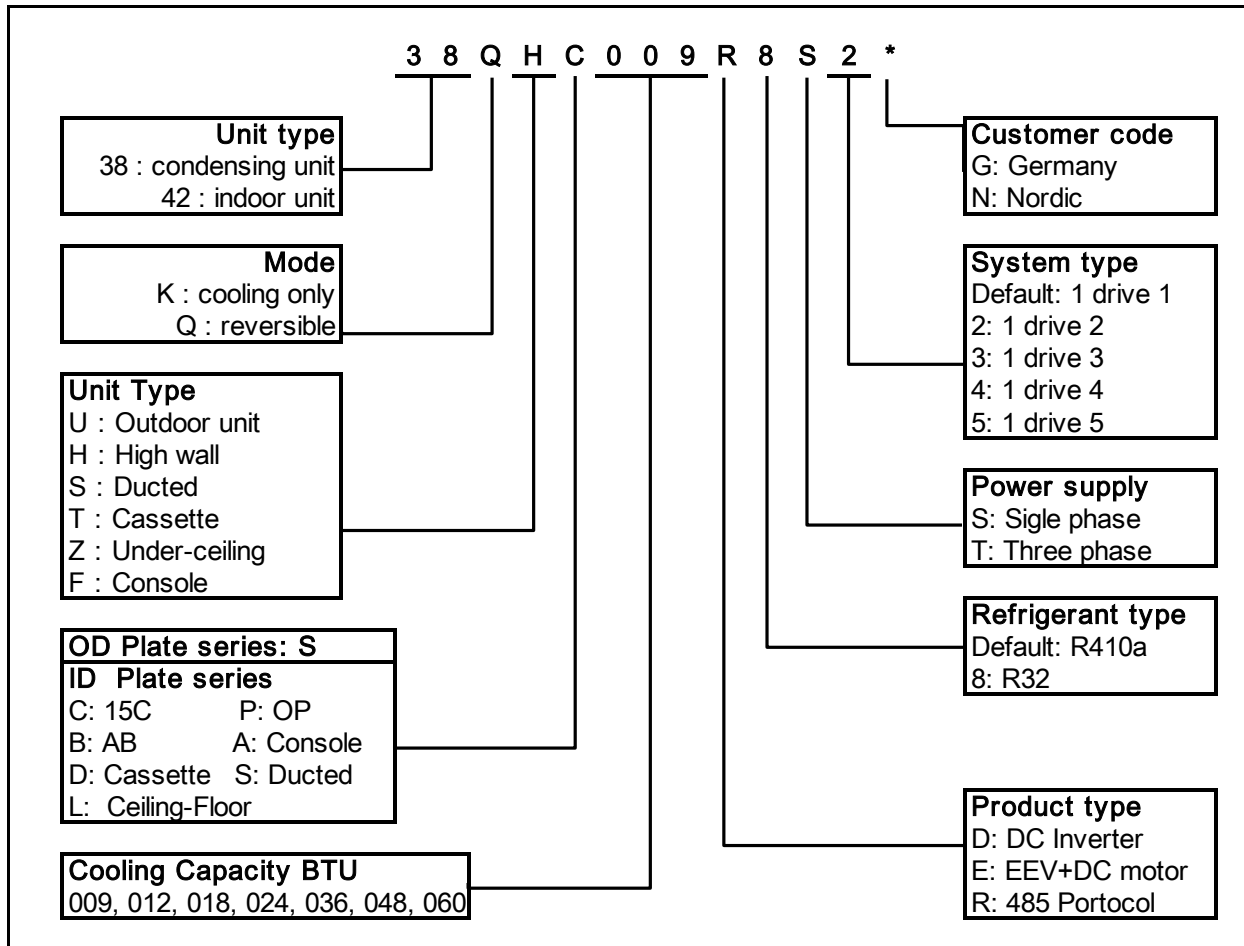

Part 2

Indoor Units

Super Slim Cassette Type	6
A6 Duct Type	22
Ceiling & Floor Type	41

Super Slim Cassette Type

1. Features.....	7
2. Dimensions.....	10
3. Service Space.....	11
4. Wiring Diagrams	12
5. Air Velocity Distributions (Reference Data)	13
6. Electric Characteristics.....	16
7. Sound Levels.....	17
8. Accessories.....	18
9. The Specification of Power	19
10. Field Wiring	20

1. Features

1.1 Overview

- Compact design, super slim body size, less space requiring in installation
- Each louver can be separately controlled, more comfort air blowing is possible.

1.2 Fresh air intake function

- Fresh air fulfills air quality more healthy and comfortable.
- Ventilation motor is optional to increase the effect of fresh air.



1.3 Optional ionizer generator

- Ionizer generator is optional to get refreshing air to your room.

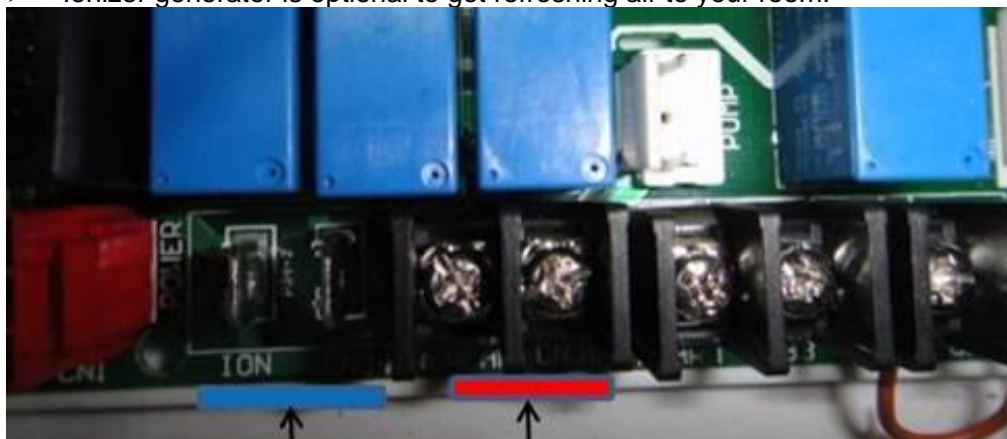

Ionizer generator
connector

Ventilation motor
connector

- Ionizer can be switched on or off by remote controller. When pressing the Clean Air button on the remote controller, Ionizer will work and the indicator light on display board will shine.



1.4 External air duct design

- Reserve external air duct, more flexible for the air supply.

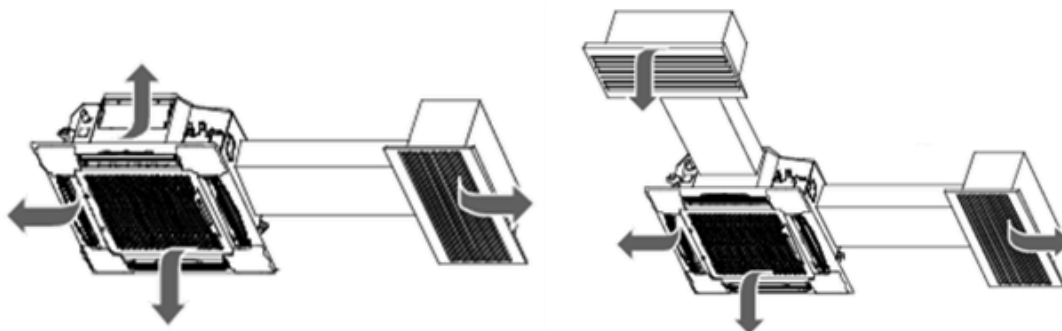

1.5 Built-in draining pump

- Due to the improvement of structure, more convenient to repair or replace the draining pump.

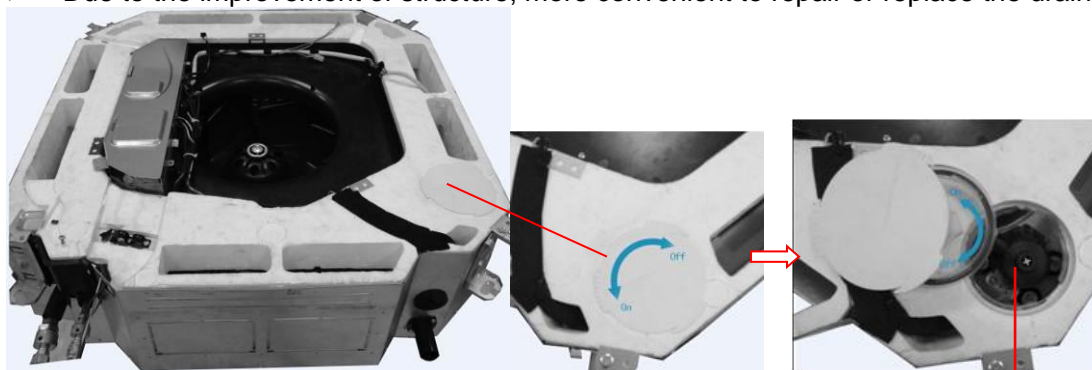

Draining Pump

- Built-in draining pump to make sure condensed water drain out reliably.

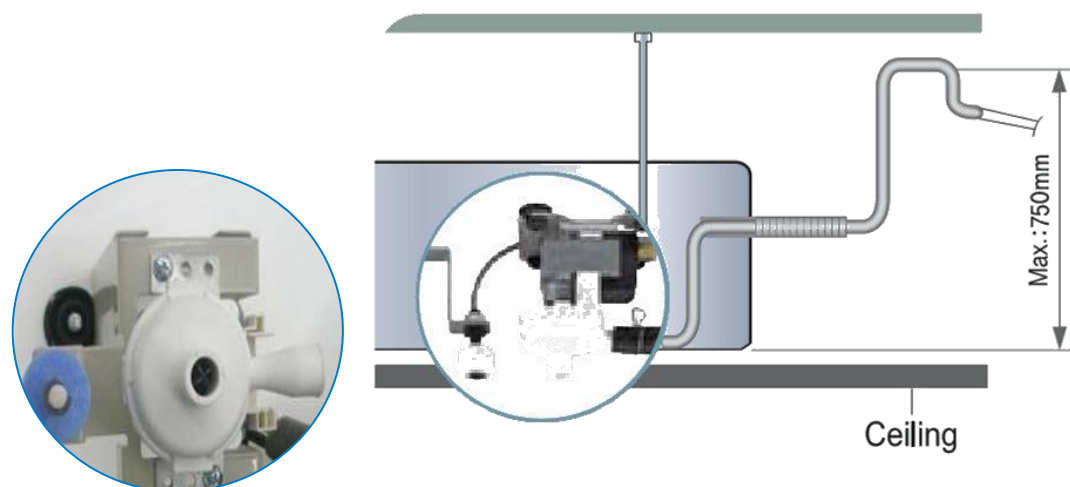

1.6 Terminals for alarm lamp and long-distance on-off controller connection are standard

- Reserve terminals for the connection of alarm lamp and long-distance on-off controller, more human control.



Alarm lamp

Long-distance on-off controller

1.7 Twins Combination(18k-30k)

- The units can be installed as Twin systems: one outdoor unit can connect with two indoor units. The indoor units can be combined in any of the different available ratings.

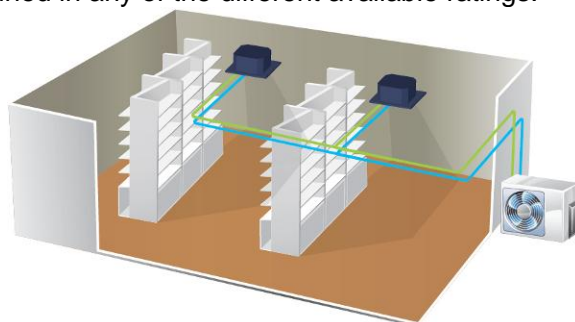

2. Dimensions

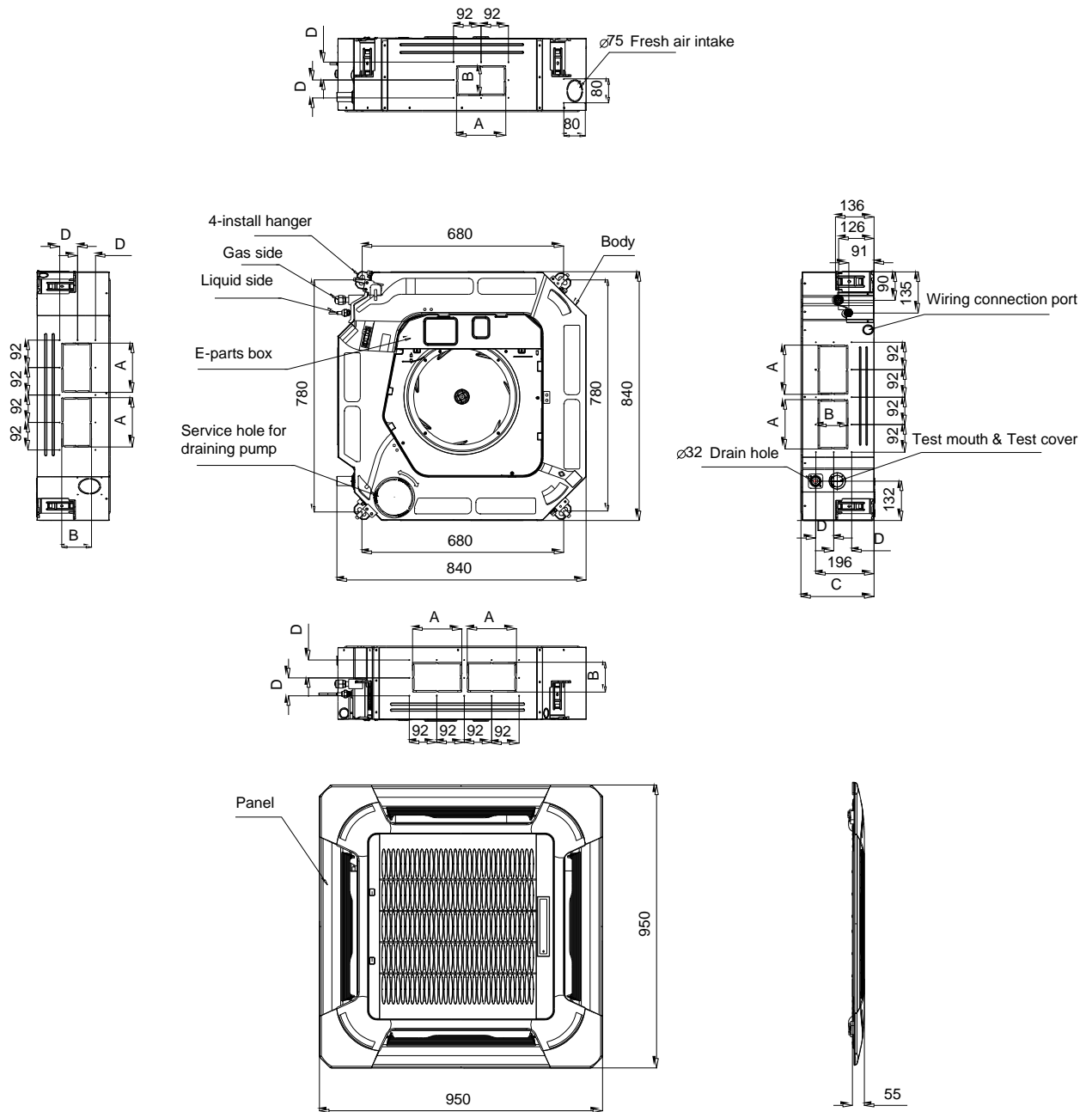

Unit: mm				
Model	A	B	C	D
42QTD018R8S*	160	75	205	50
42QTD024R8S*	160	95	245	60
42QTD036R8S*	160	95	287	60
42QTD048R8S*	160	95	287	60
42QTD060R8S*	160	95	287	60

3. Service Space

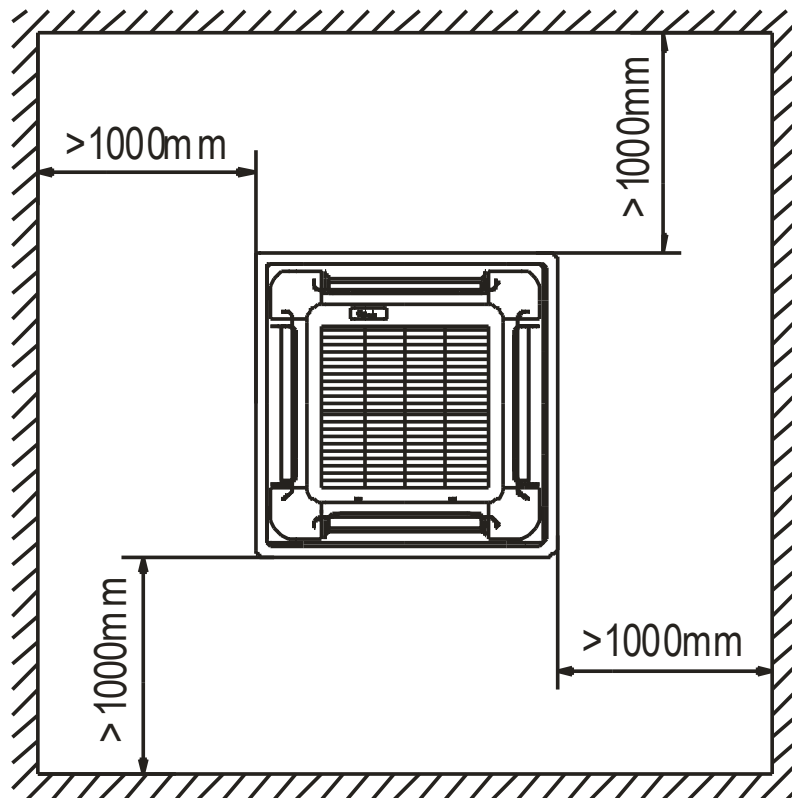

4. Wiring Diagrams

42QTD018R8S*, 42QTD024R8S*, 42QTD036R8S*, 42QTD048R8S*, 42QTD060R8S*

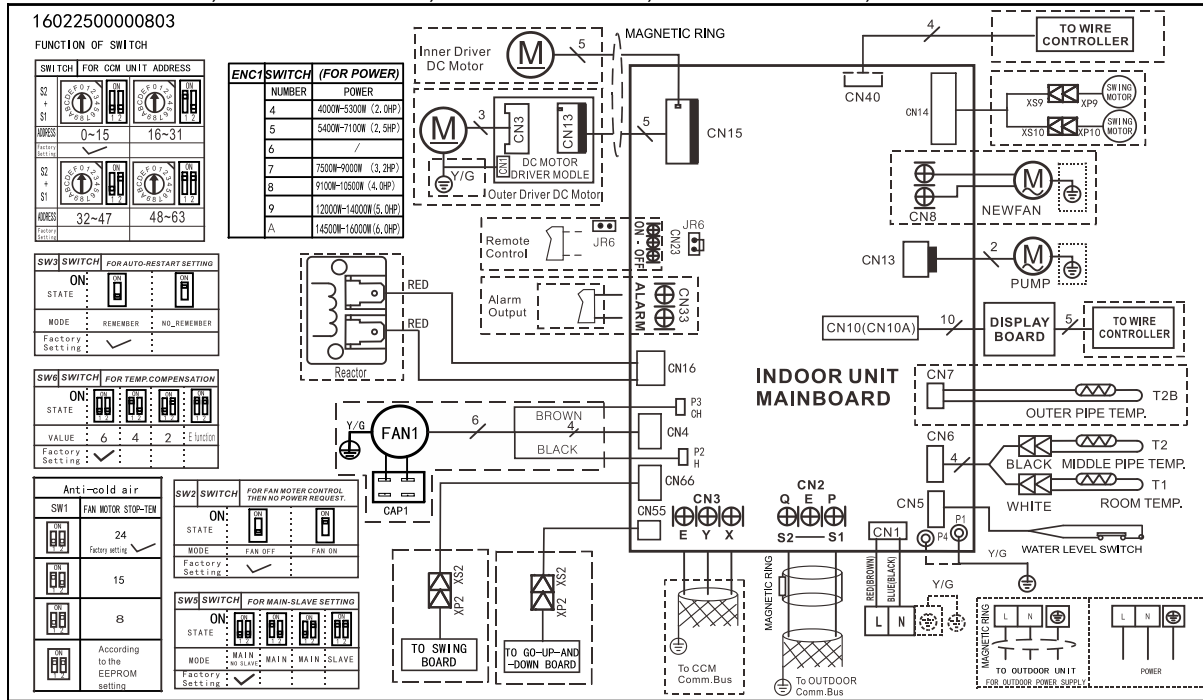

5. Air Velocity Distributions (Reference Data)

18-24K:

Cooling:

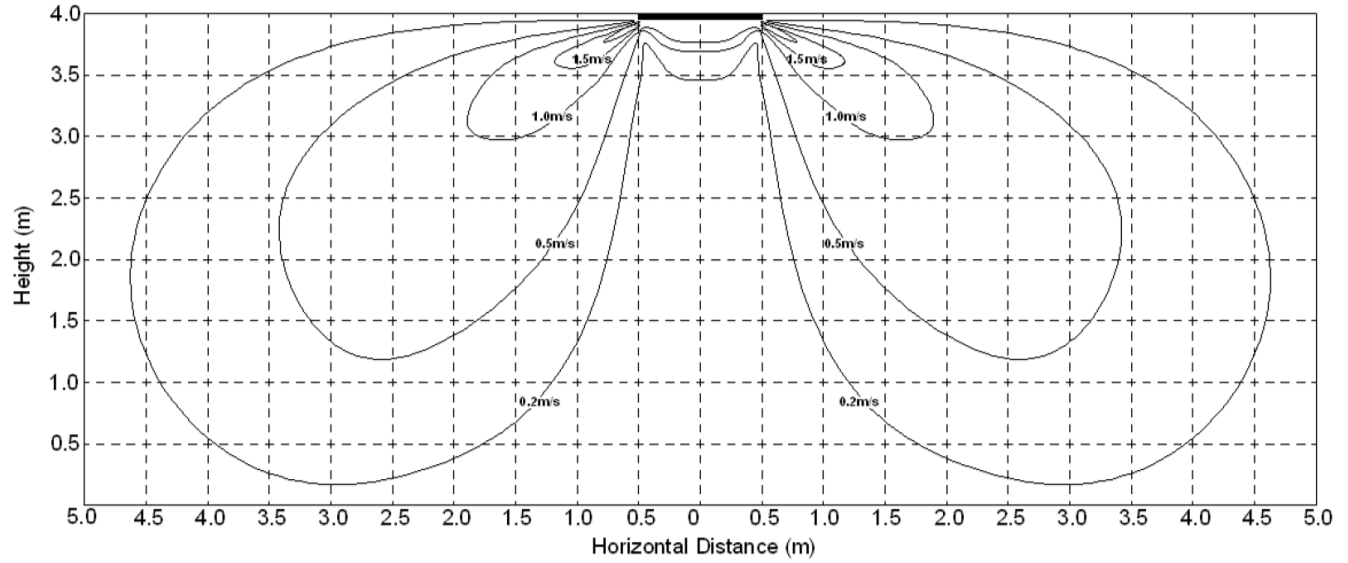

Heating:

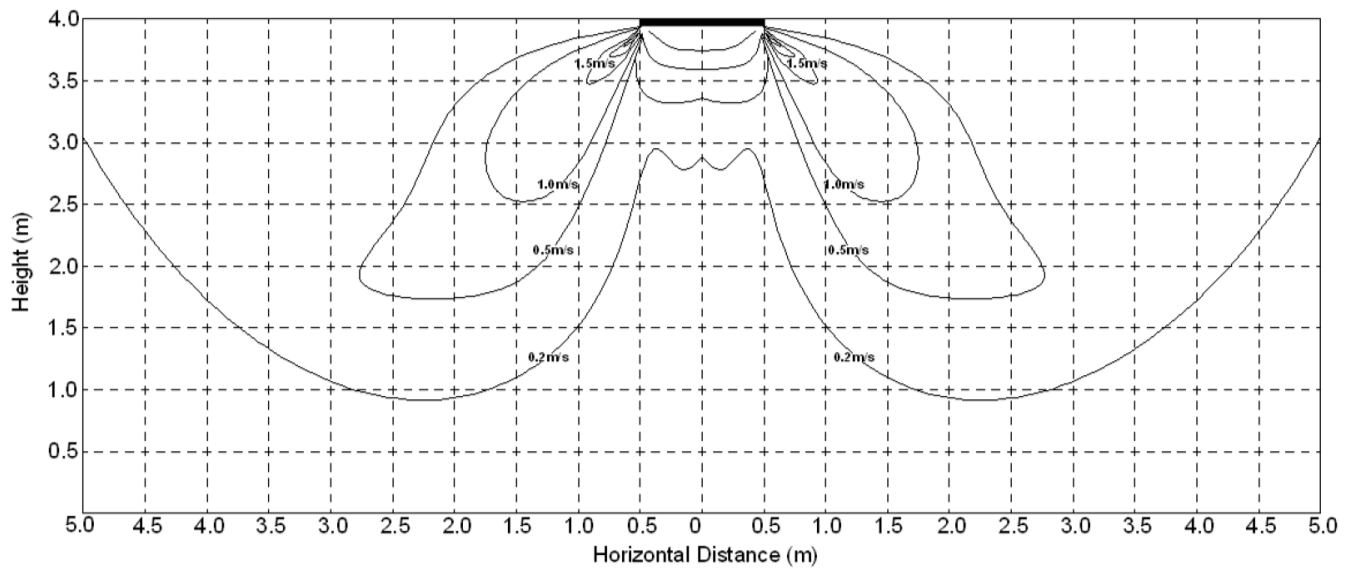

**30-42K:
Cooling:**

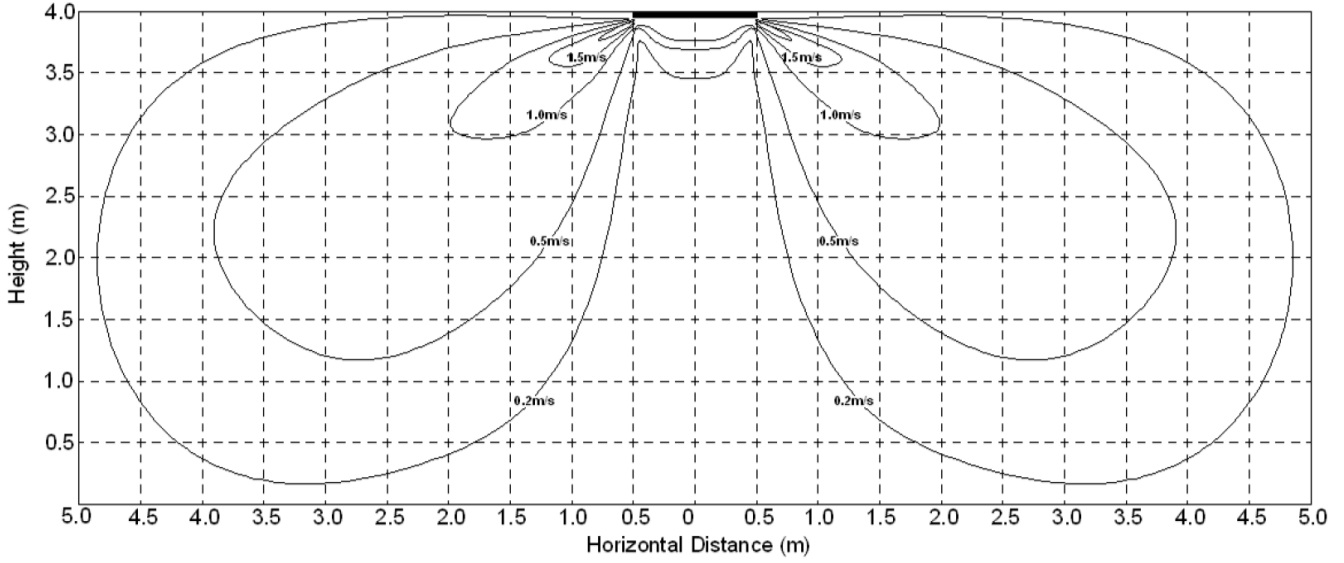

Heating:

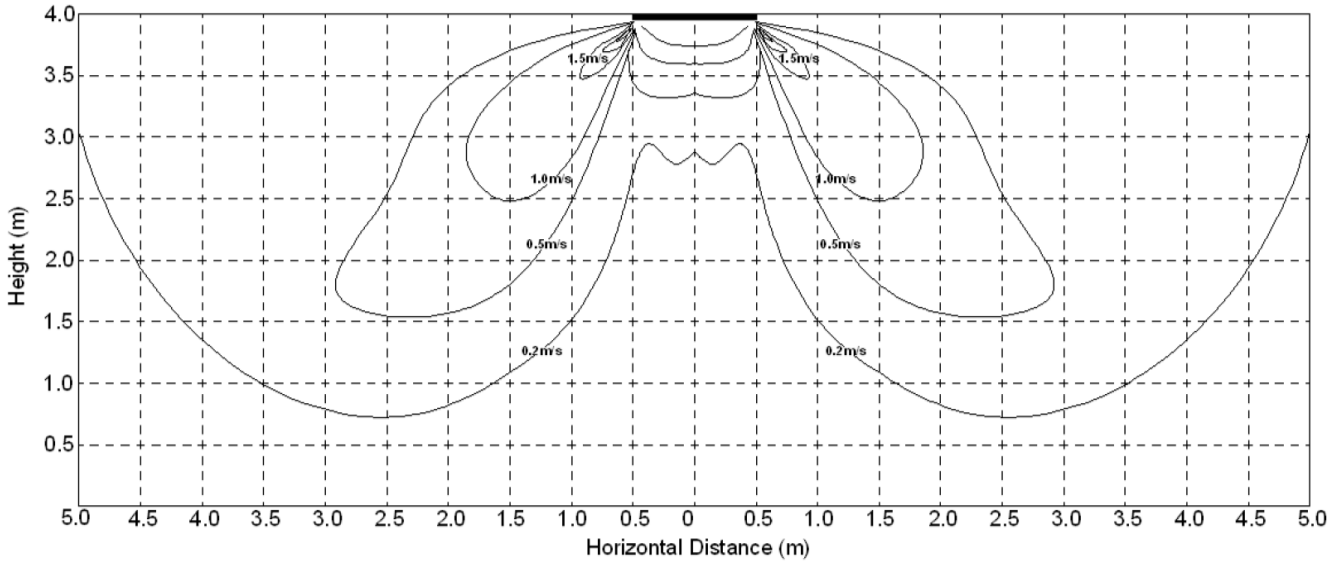

**48-55K:
Cooling:**

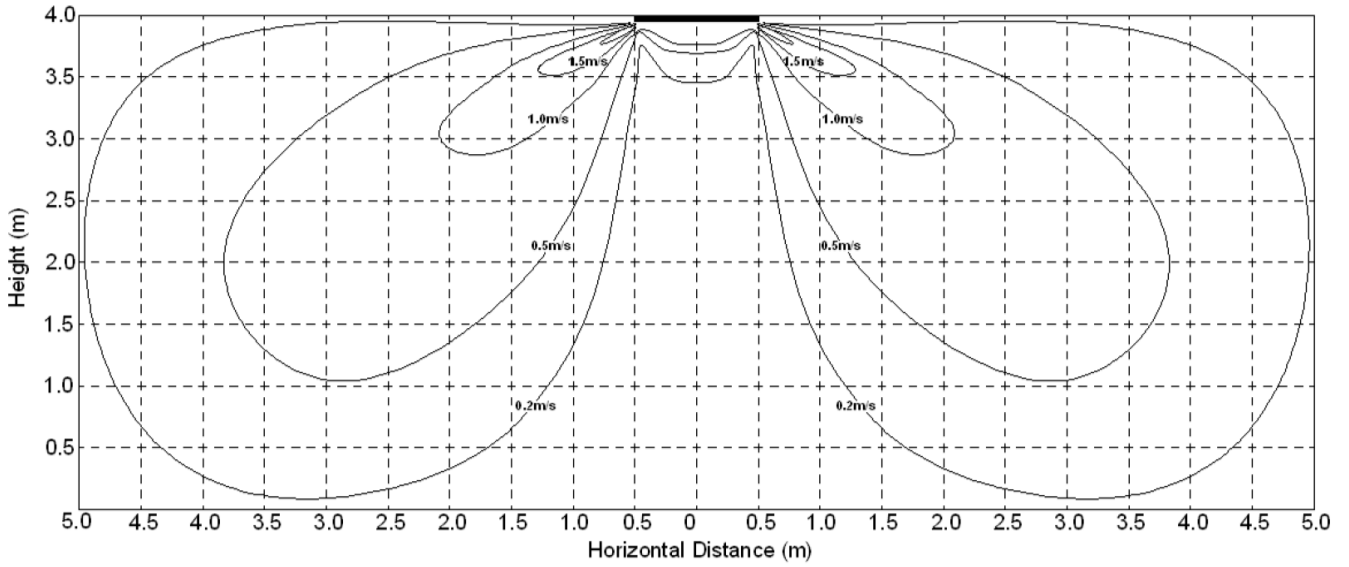

Heating:

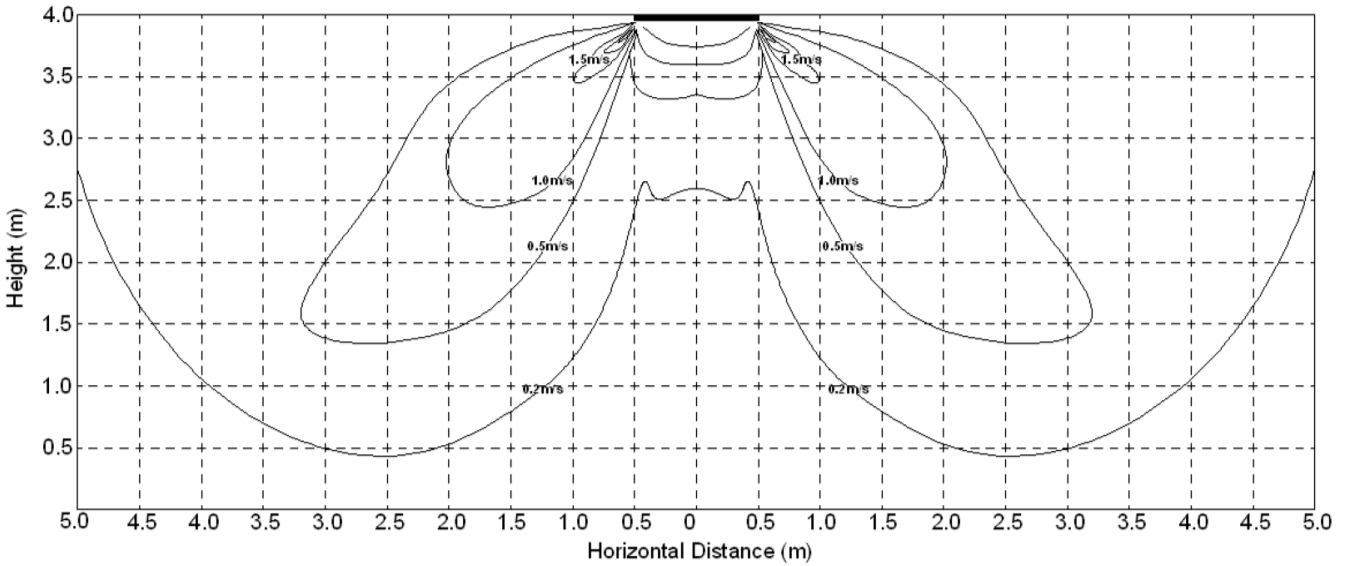

6. Electric Characteristics

Model	Indoor Unit				Power Supply
	Hz	Voltage	Min	Max	MFA
42QTD018R8S*	50	220-240V	198V	254V	10
42QTD024R8S*	50	220-240V	198V	254V	10
42QTD036R8S*	50	220-240V	198V	254V	10
42QTD048R8S*	50	220-240V	198V	254V	/
42QTD060R8S*	50	220-240V	198V	254V	/

Notes:





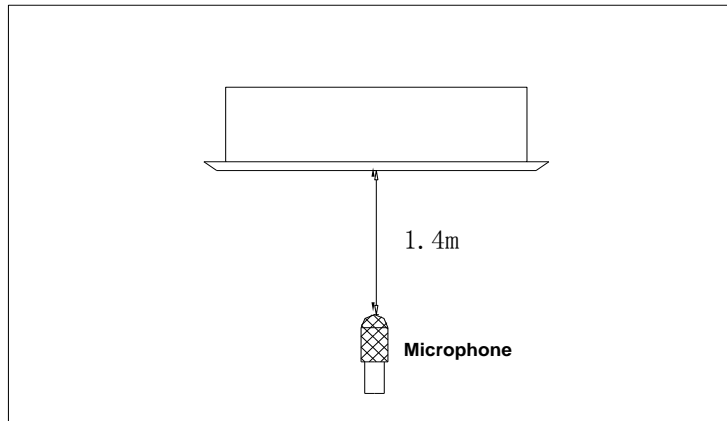









MFA: Max. Fuse Amps. (A)

7. Sound Levels

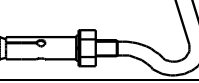
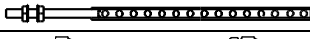

Model	Noise Power dB(A)	Noise level dB(A)		
		H	M	L
42QTD018R8S*	57	45	40	37
42QTD024R8S*	61	46	43	40
42QTD036R8S*	63	51	49	46
42QTD048R8S*	65	52	50	49
42QTD060R8S*	65	53	50	48

8. Accessories

	Name	Shape	Quantity
Installation Fittings	Installation paper board		1
Tubing & Fittings	Soundproof / insulation sheath		1
Drainpipe Fittings	Out-let pipe sheath		1
	Out-let pipe clasp		1
	Drain joint		1
	Seal ring		1
Remote controller & Its Frame (The product you have might not be provided the following accessories)	Remote controller & Its Frame		1
	Remote controller holder		1
	Mounting screw(ST2.9x10-C-H)		2
	Remote controller manual		1
	Alkaline dry batteries (AM4)		2
Others	Owner's manual		1
	Installation manual		1
Installation accessory (The product you have might not be provided the following accessories)	Expansible hook		4
	Installation hook		4
	Orifice		1

9. The Specification of Power

Model(Btu/h)		18000~24000	36000	36000	48000~60000
Indoor Power	Phase	1-phase	1-phase	1-phase	————
	Frequency and Voltage	220-240V, 50Hz	220-240V, 50Hz	220-240V, 50Hz	————
	POWER WIRING (mm ²)	3×1.0	3×1.0	3×1.0	————
CIRCUIT BREAKER/Fuse (A)		15/10	15/10	15/10	————
Outdoor Power	Phase	1-phase	1-phase	3-phase	3-phase
	Frequency and Voltage	220-240V, 50Hz	220-240V, 50Hz	380-415V, 50Hz	380-415V, 50Hz
	POWER WIRING (mm ²)	3×2.5	3×4.0	5×2.5	5×2.5
CIRCUIT BREAKER/Fuse (A)		25/20	40/30	25/20	30/25
Indoor/Outdoor Connecting Wiring (Weak Electric Signal) (mm ²)		2×0.2	2×0.2	2×0.2	2×0.2
Indoor/Outdoor Connecting Wiring (Strong Electric Signal) (mm ²)		————	————	————	3×1.0

10. Field Wiring

42QTD018R8S*, 42QTD024R8S*, 42QTD036R8S*

Air Condition Link-Circuit

202044790380

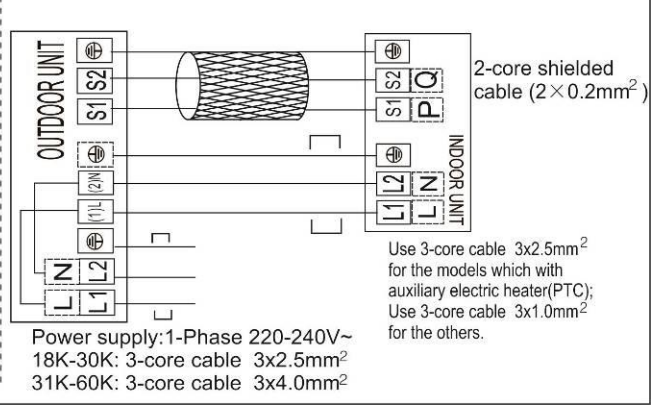
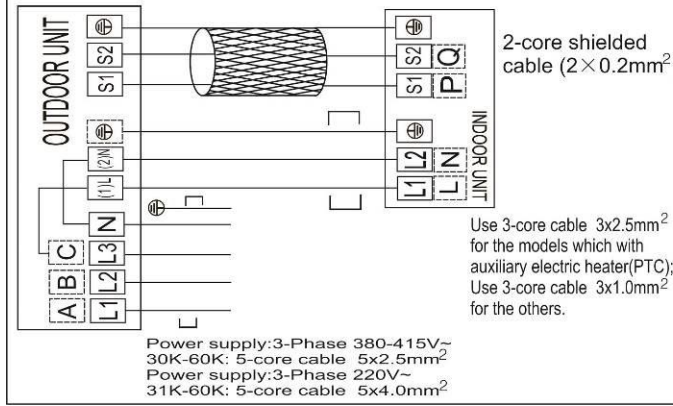
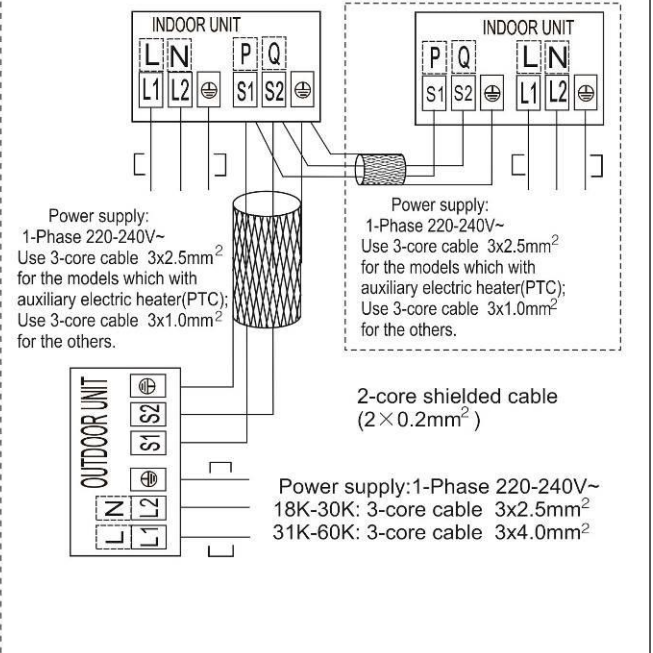
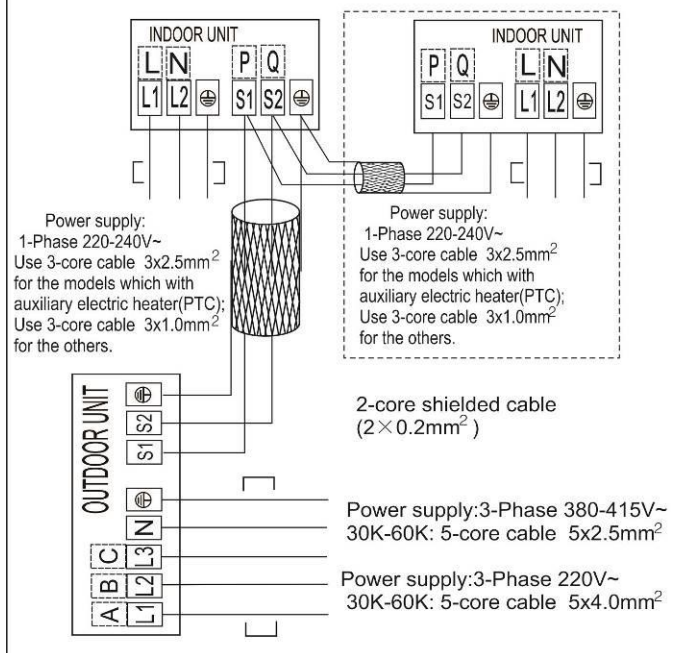

42QTD048R8S*, 42QTD060R8S*

Air Condition Link-Circuit

16023000006042

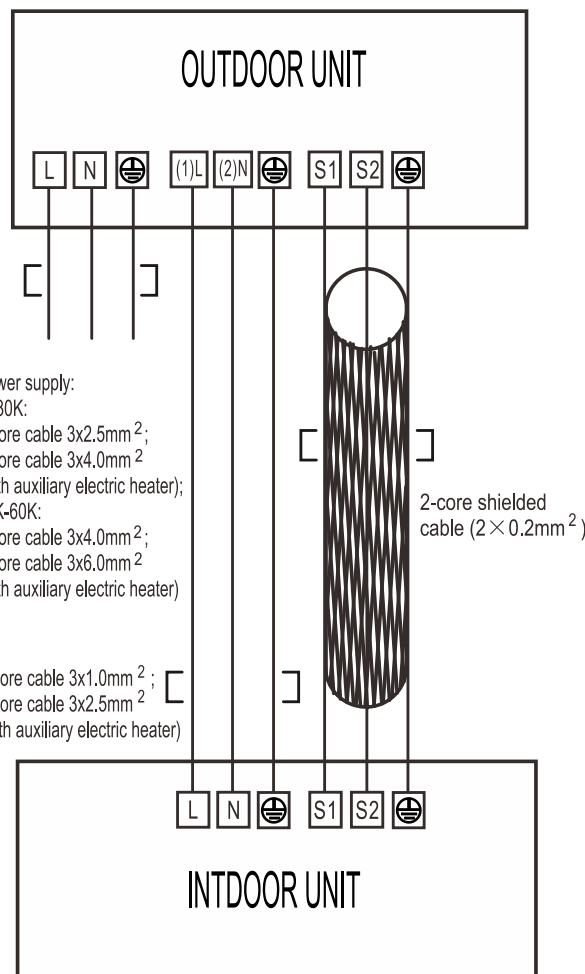
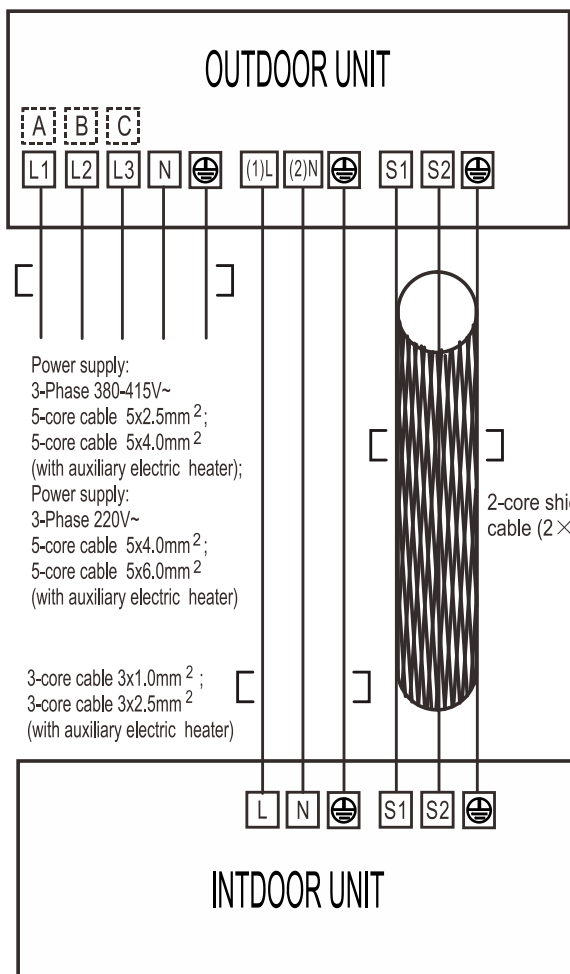

A6 Duct Type

1. Features.....	23
2. Dimensions.....	28
3. Service Space.....	29
4. Wiring Diagrams	30
5. Static Pressure.....	31
6. Electric Characteristics	36
7. Sound Levels.....	37
8. Accessories	38
9. The Specification of Power	39
10. Field Wiring	40

1. Features

1.1 Higher Static Pressure

- As a ducted air conditioner with medium static pressure, it has the widest static pressure range.
- The maximum static pressure reaches 160 Pa



1.2 Slim Design

- The industry Lowest height is designed to be fitted into tight roof spaces.
- *18K unit - 210mm, 24K/36K unit - 249mm, 48K unit - 300mm

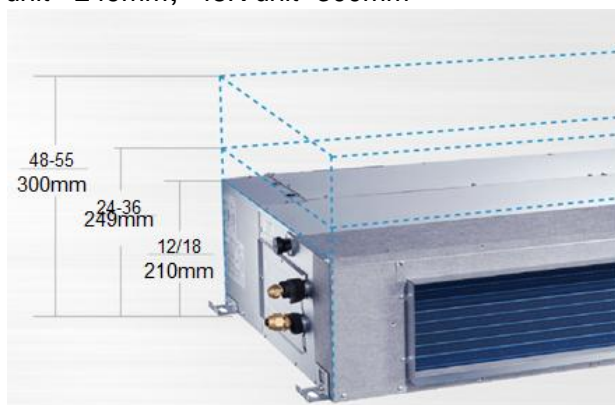

1.3 Constant air volume control

- For ordinary duct, when the static pressure exceeds the expected range, it is fairly difficult even for an experienced installer to calculate and adjust the air volume precisely.
- With constant air volume control technology, the duct will automatically adjust to perfect static pressure and keep constant air volume.

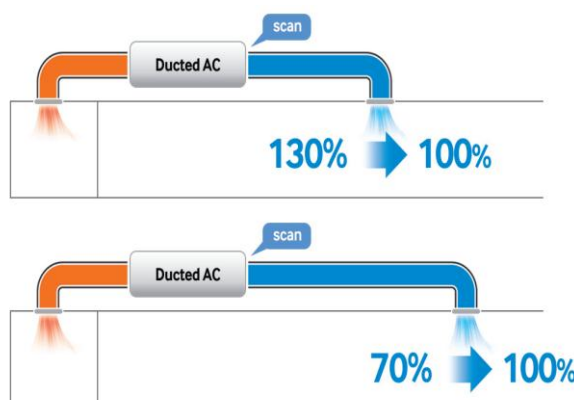

1.4 Installation accessories: (Optional)

- Front Board, Filter, Panel, for easy installation

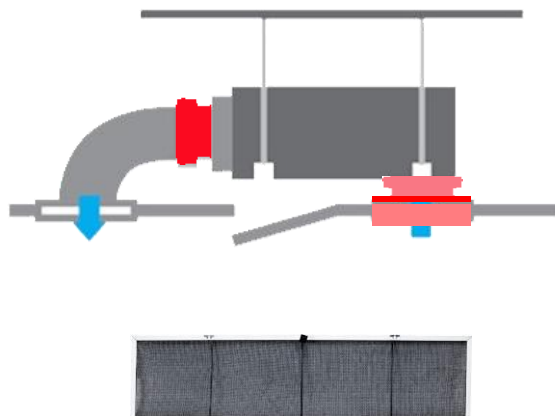

Filter

1.5 Flexible Air Intake Way (Bottom side or Rear side)

- The frame size of air inlet in rear and bottom is the same. It's very easy to switch to match different application.

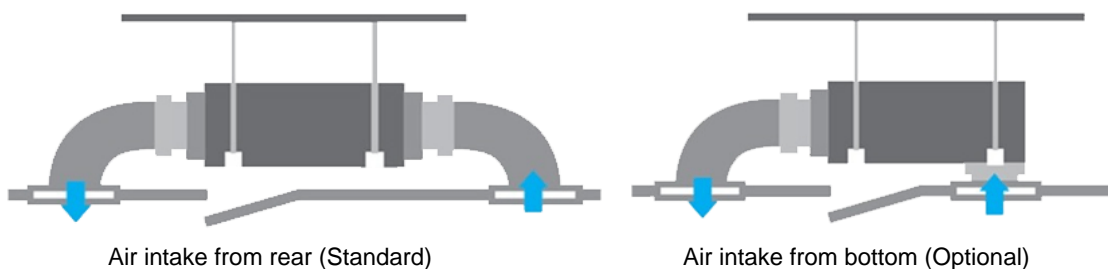

1.6 Communication wire connection

- A6 duct uses two wires without polarity connection way, which almost has no mistake during the installation.



1.7 Easy Clean

- Clean the filter (Optional, standard product without filter)
- It is easy to draw out the filter from the indoor unit for cleaning, even the filter is installed in rear side or bottom side.

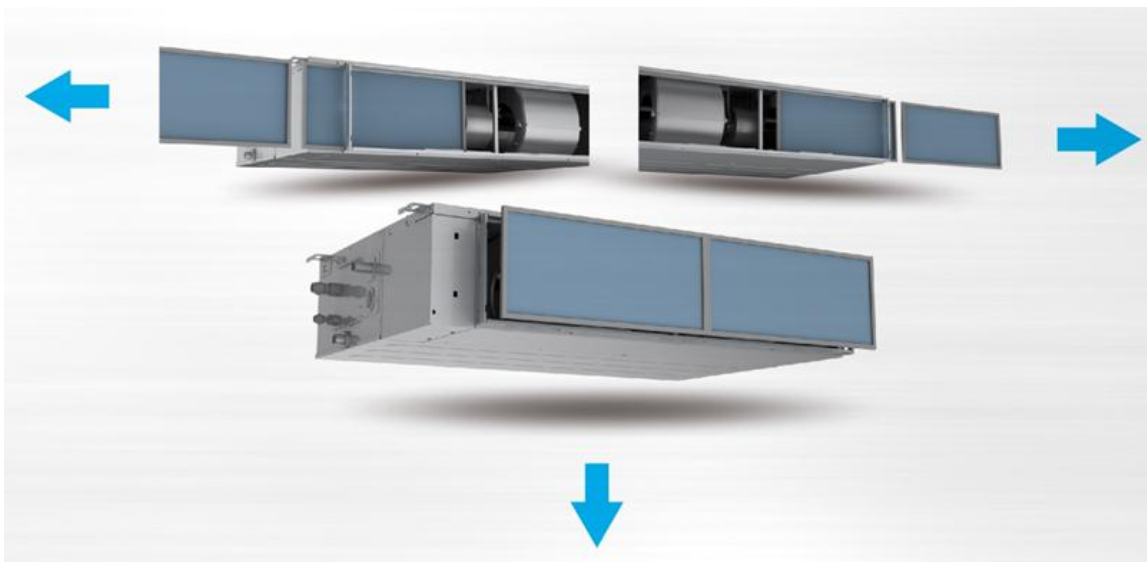

- With a larger window design, once the motor and the blower wheels have been detached, heat exchanger and water receiver tray in behind can be seen very clearly. Dust can be easily removed from the inside by vacuum



1.8 Easy maintenance

- A6 duct allows operators maintenance the motor from the bottom more easily compare with that on the top.

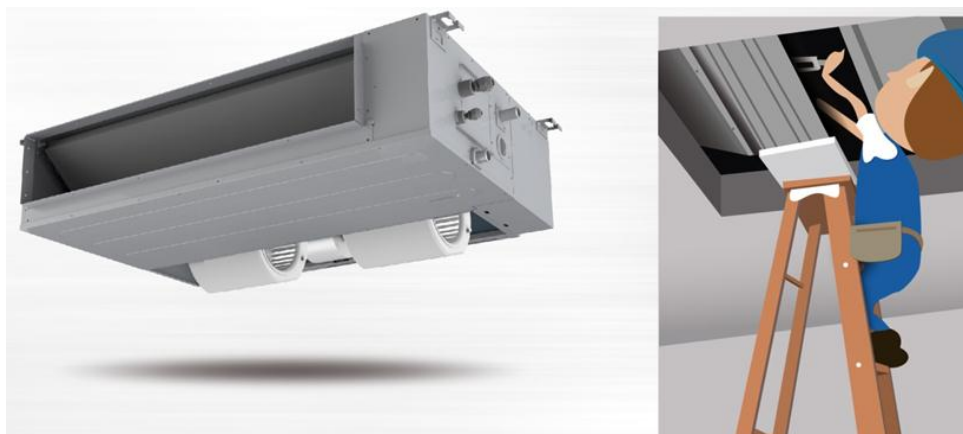

- A6 duct has big space for maintenance at the side

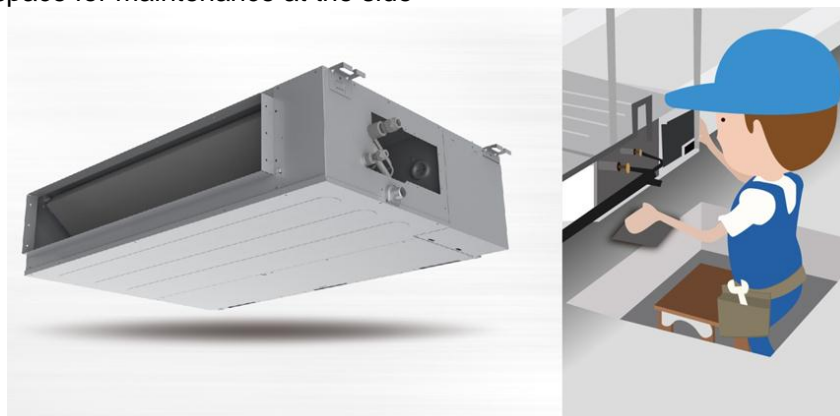

1.9 Twins Function

- The twin system connects two indoor units of the same type and capacity to one outdoor unit in order to ensure more air distribution in a large zone. The controller can only control the master unit. The slave unit will work in the same state as the master unit.

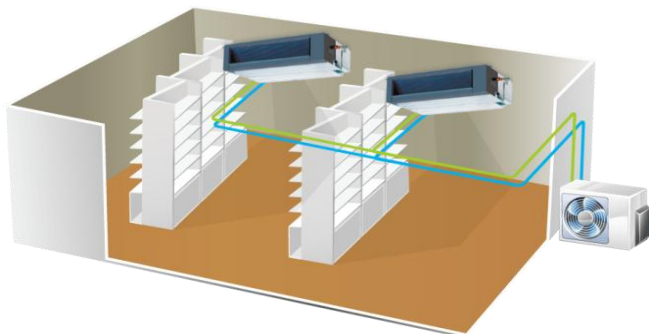

	Outdoor Unit	Indoor Units
Twin System	36K	18K + 18K
	48K	24K + 24K
	60K	30K + 30K

1.10 Fresh air intake function(Optional)

- Install one duct from the reserved fresh-air intake to outdoor. Continually inhale the fresh air to improve the quality of the indoor air, fulfills air quality more healthy and comfortable.
- A ventilation motor (provided by the installer) can be installed inside the fresh air duct to improve the fresh air volume. There are reserved ports for this motor on main PCB (Standard for 3D inverter units, and only optional for DC inverter 53~160 units).

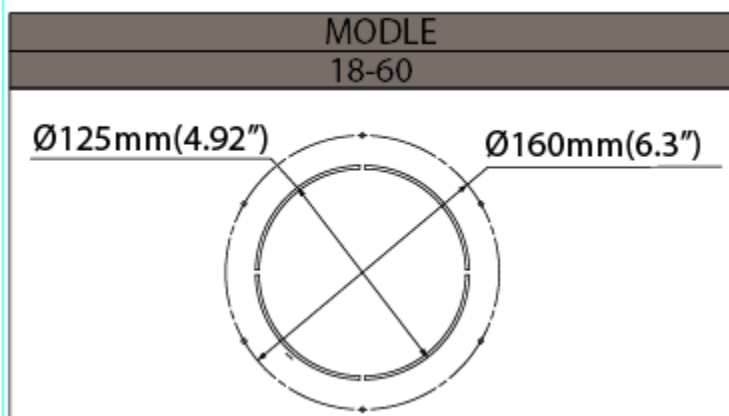

1.11 Built-in drain pump (Optional)

- Built-in drain pump can lift the water to 750mm upmost, which widens the drainage piping range.

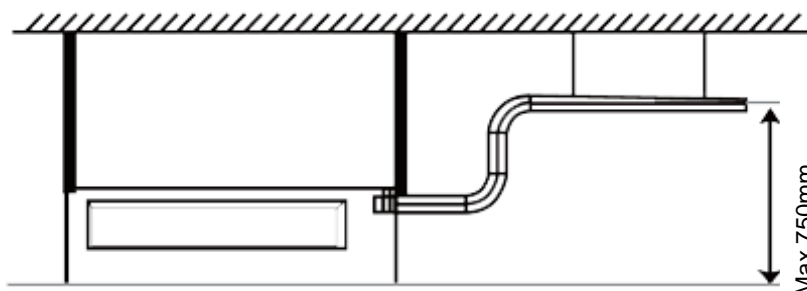

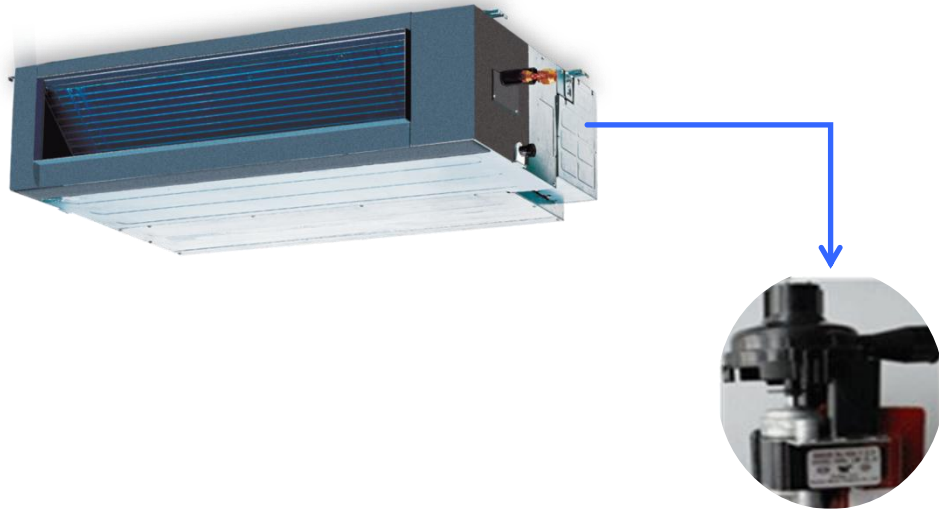

2. Dimensions

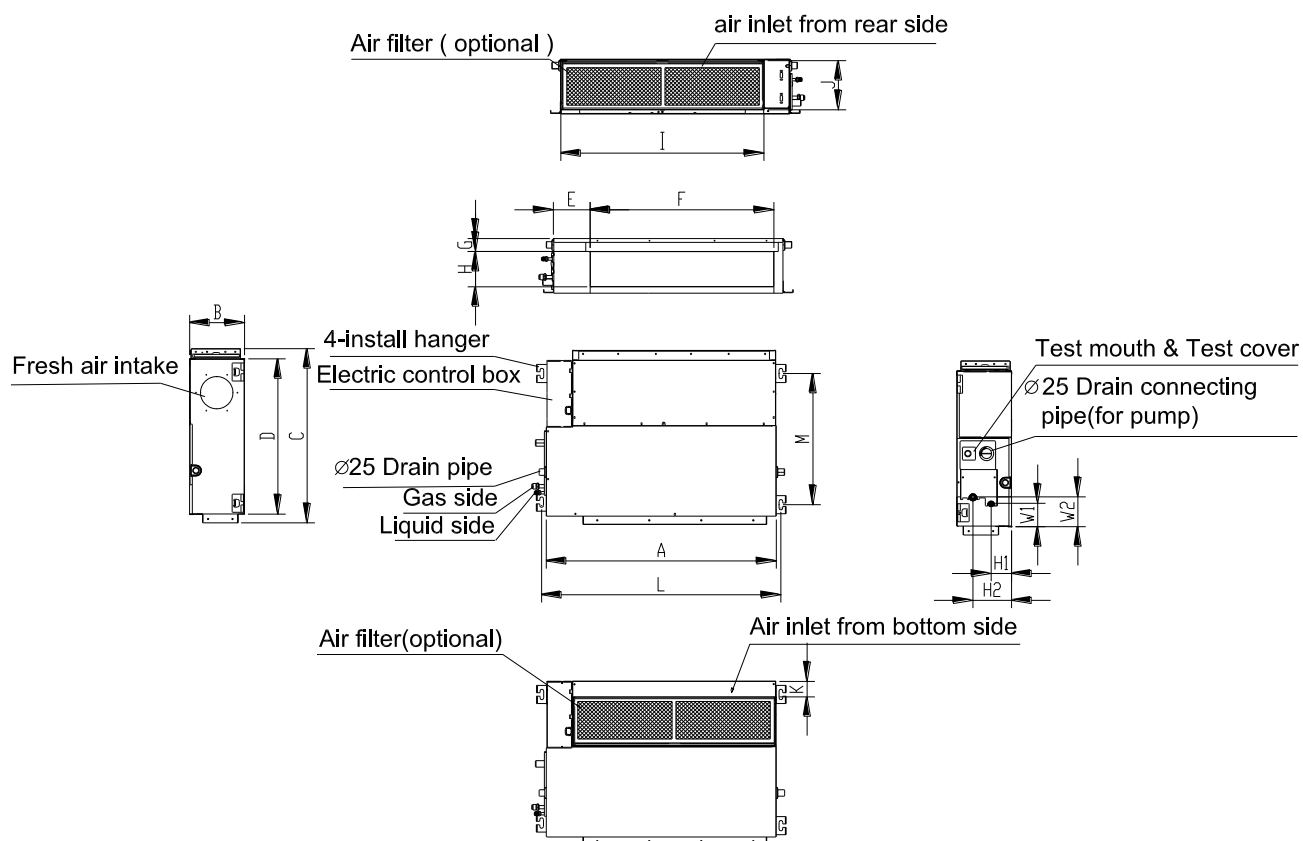

Model (Kbtu/h)	unit	A	B	C	D	E	F	G	H	I	J	K	L	M	H1	H2	W1	W2
18	mm	880	210	674	600	140	706	50	136	782	190	40	920	508	78	148	88	112
	inch	34.65	8.27	26.54	23.62	5.51	27.80	1.97	5.35	30.79	7.48	1.57	36.22	20.00	3.07	5.83	3.46	4.41
24	mm	1100	249	774	700	140	926	50	175	1001	228	5	1140	598	80	150	130	155
	inch	43.31	9.80	30.47	27.56	5.51	36.46	1.97	6.89	39.41	8.98	0.20	44.88	23.54	3.15	5.91	5.12	6.10
36	mm	1360	249	774	700	140	1186	50	175	1261	228	5	1400	598	80	150	130	155
	inch	53.54	9.80	30.47	27.56	5.51	46.69	1.97	6.89	49.65	8.98	0.20	55.12	23.54	3.15	5.91	5.12	6.10
48/55	mm	1200	300	874	800	123	1044	50	227	1101	280	5	1240	697	80	150	185	210
	inch	47.24	11.81	34.41	31.5	4.84	41.1	1.97	8.94	43.35	11.02	0.20	48.82	27.44	3.15	5.91	7.28	8.27

3. Service Space

Ensure enough space required for installation and maintenance.

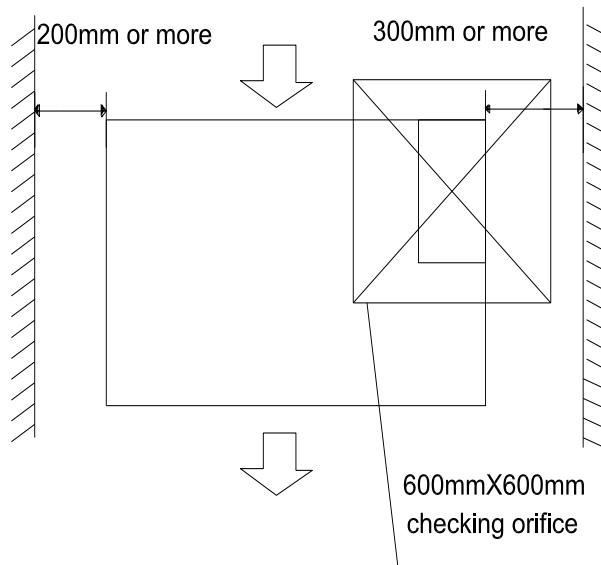

4. Wiring Diagrams

42QSS018R8S*, 42QSS024R8S*, 42QSS036R8S*, 42QSS048R8S*
 42QSS060R8S*

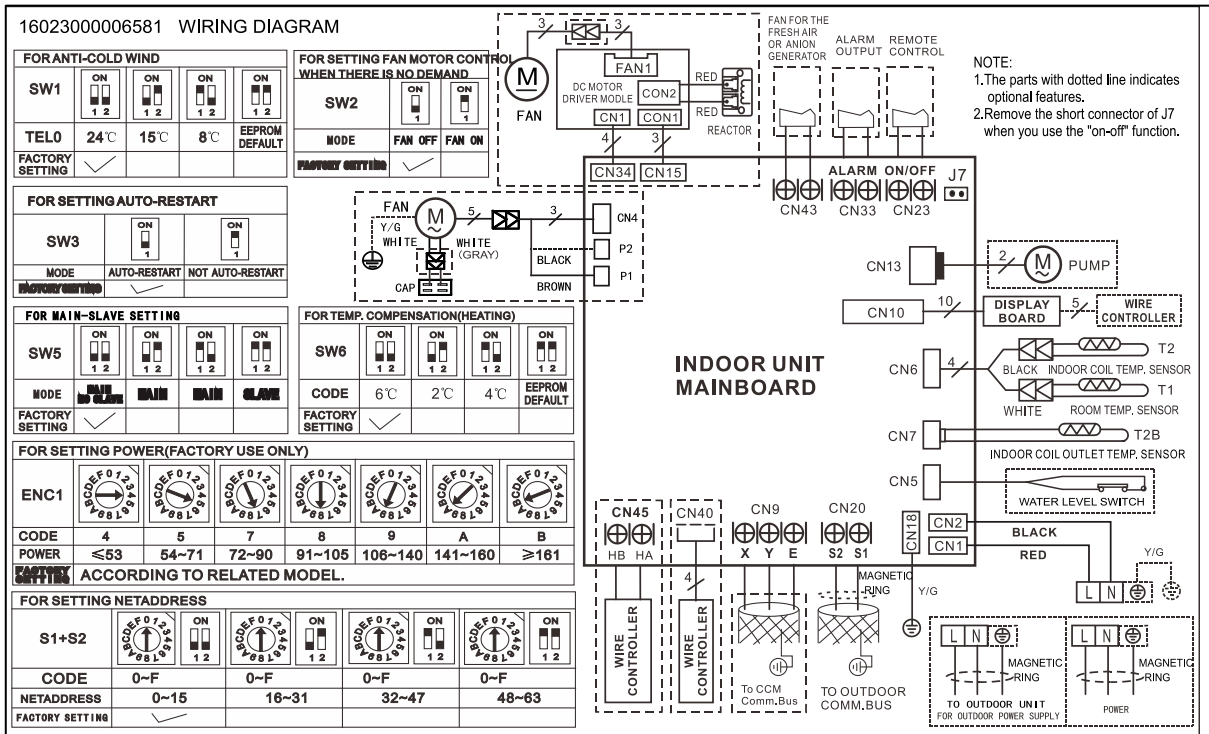

5. Static Pressure

42QSS018R8S*

Air flow rate (L/S)
(with filter)

(with filter)

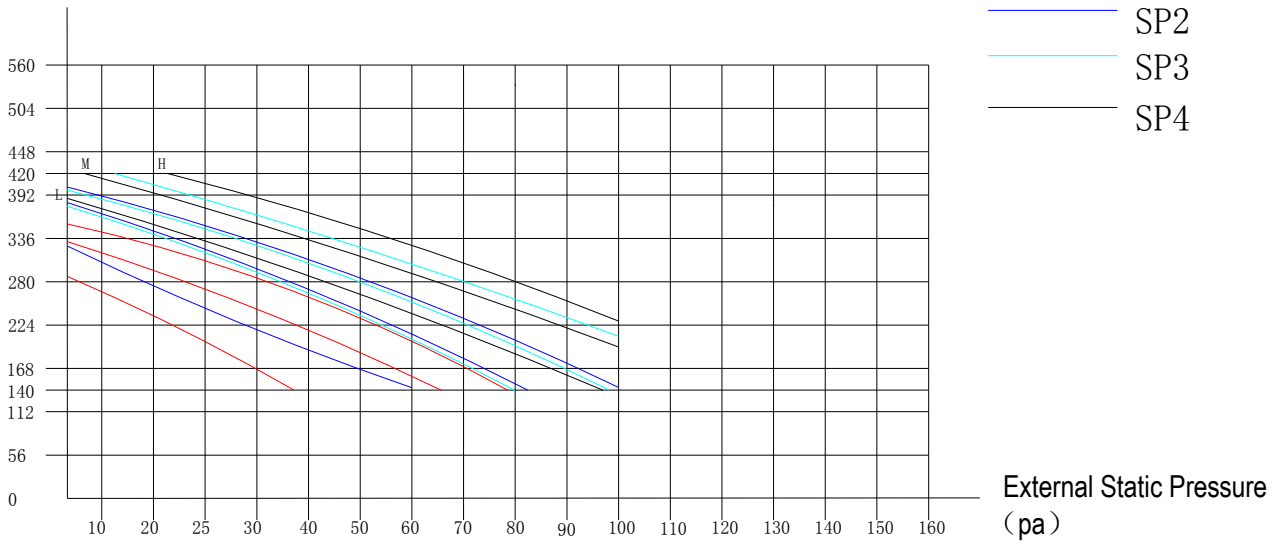

Air flow rate (L/S)
(no filter)

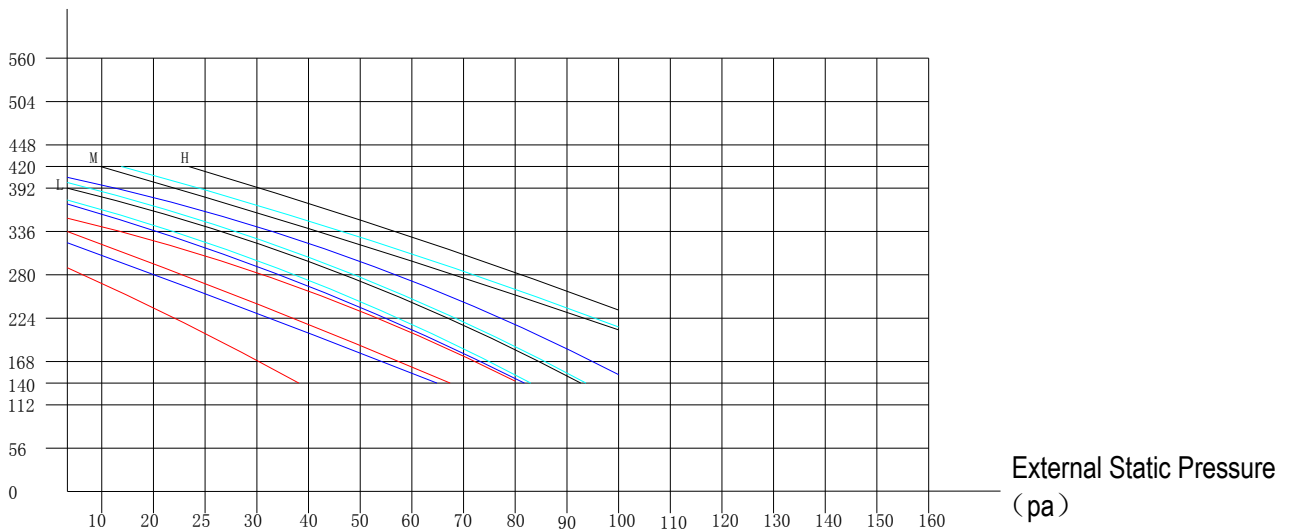

42QSS024R8S*

Air flow rate (L/S)
(with filter)

- SP1
- SP2
- SP3
- SP4

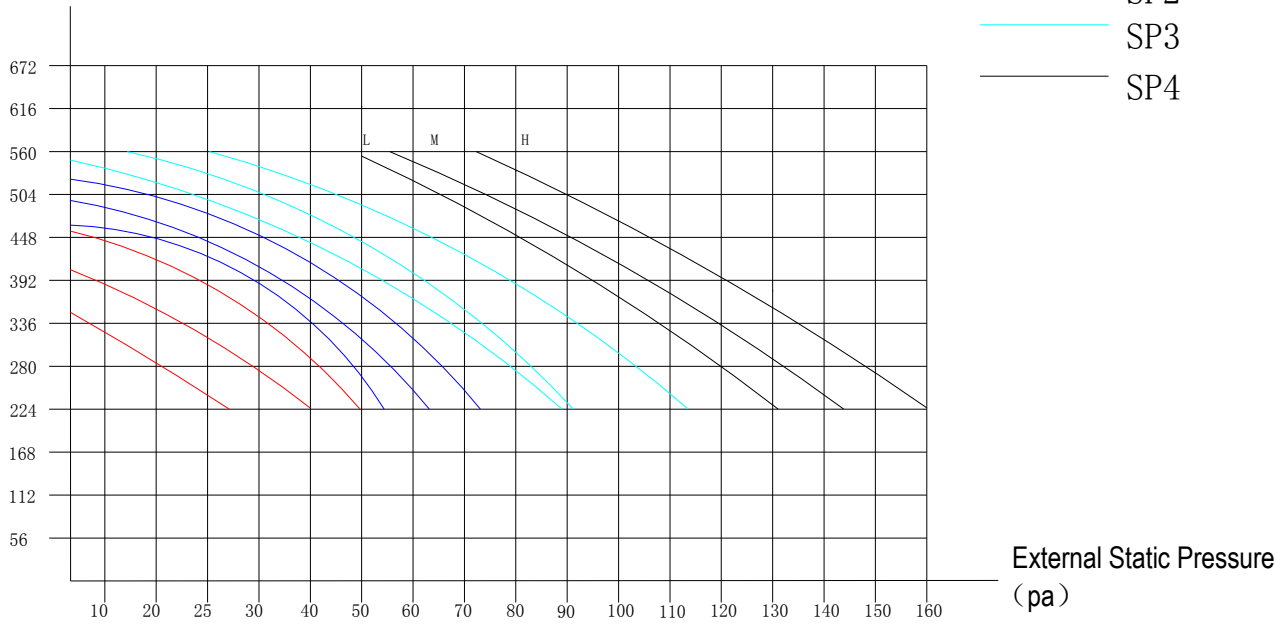

Air flow rate (L/S)
(no filter)

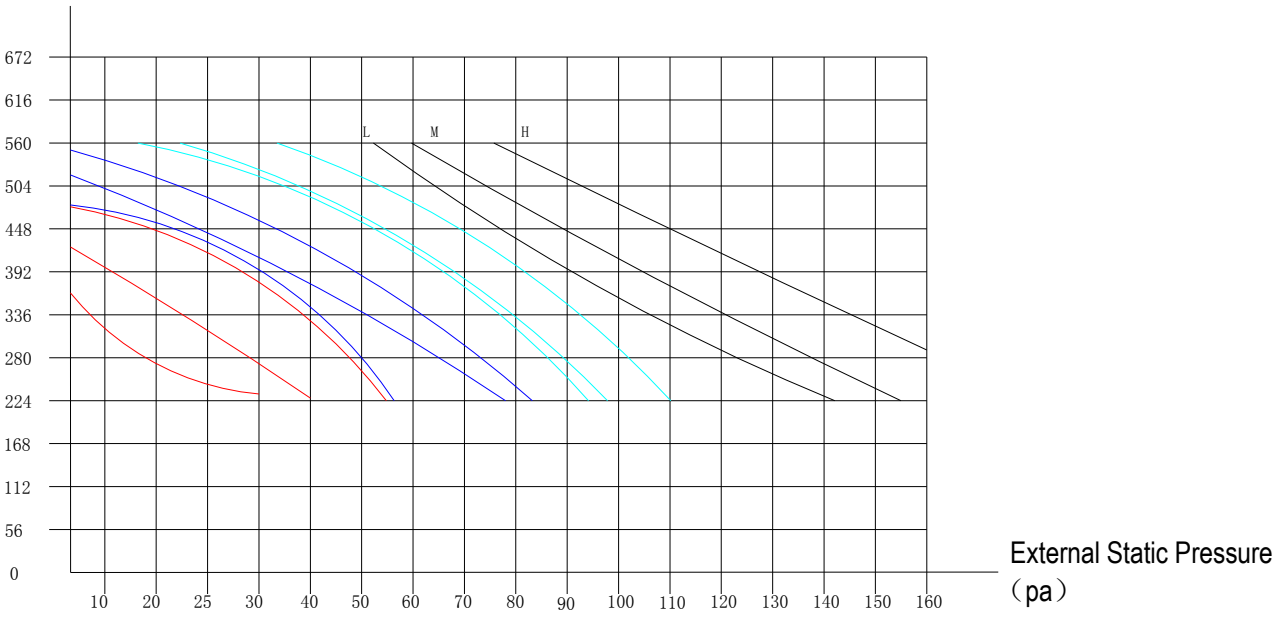

42QSS036R8S*

Air flow rate (L/S)
(with filter)

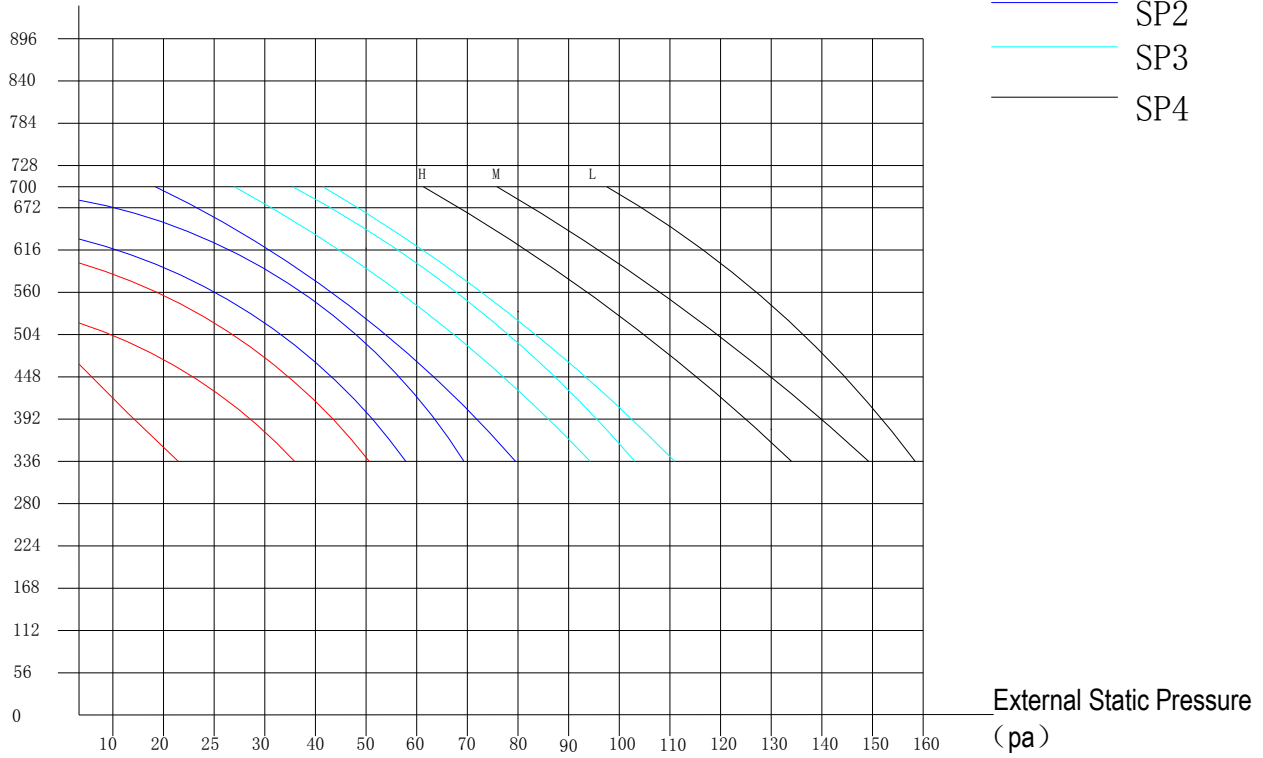

Air flow rate (L/S)
(no filter)

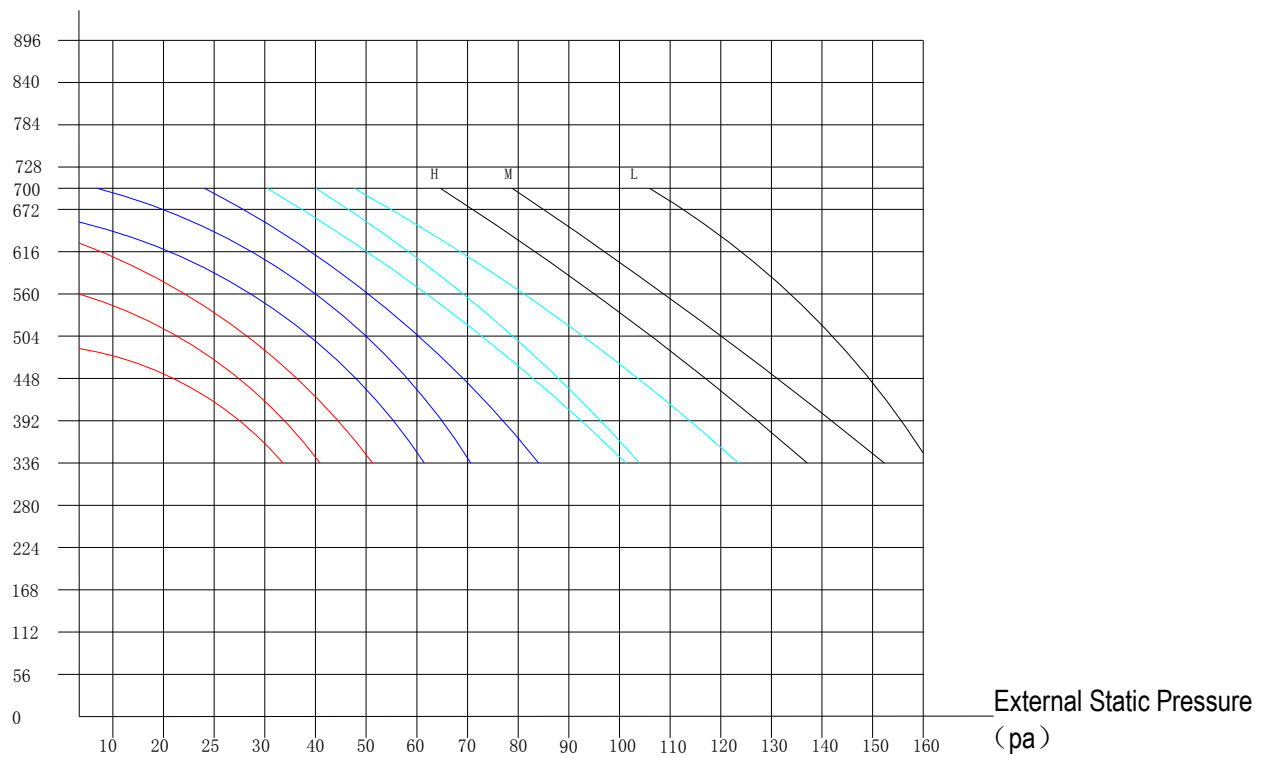

42QSS048R8S*

Air flow rate (L/S)
(with filter)

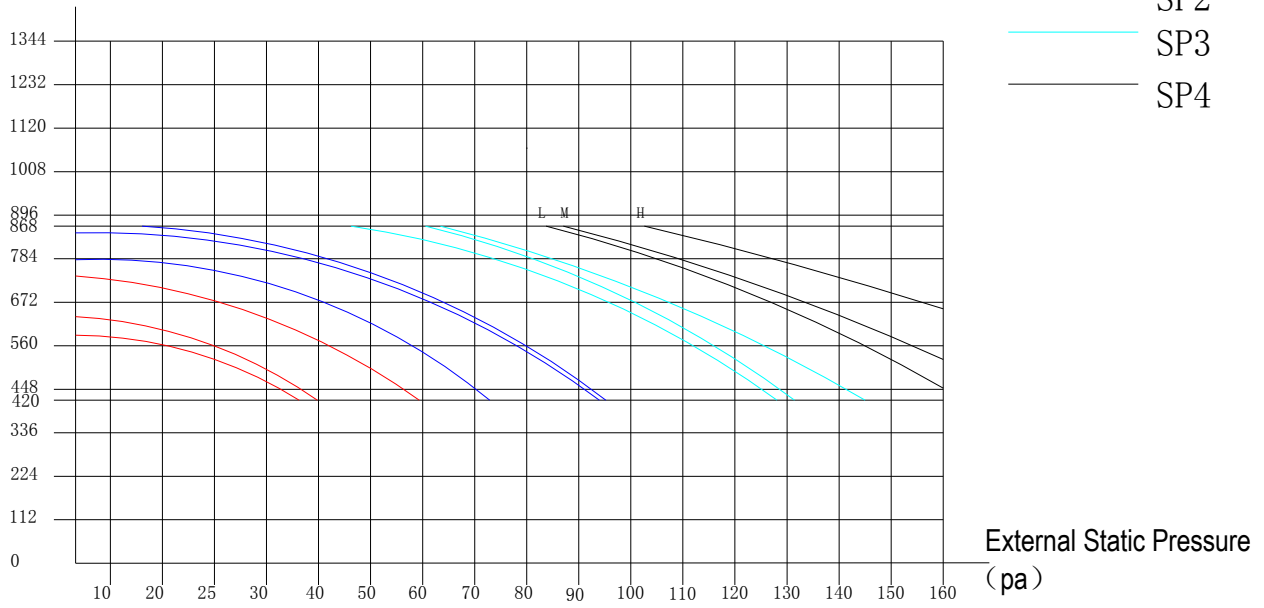

Air flow rate (L/S)
(no filter)

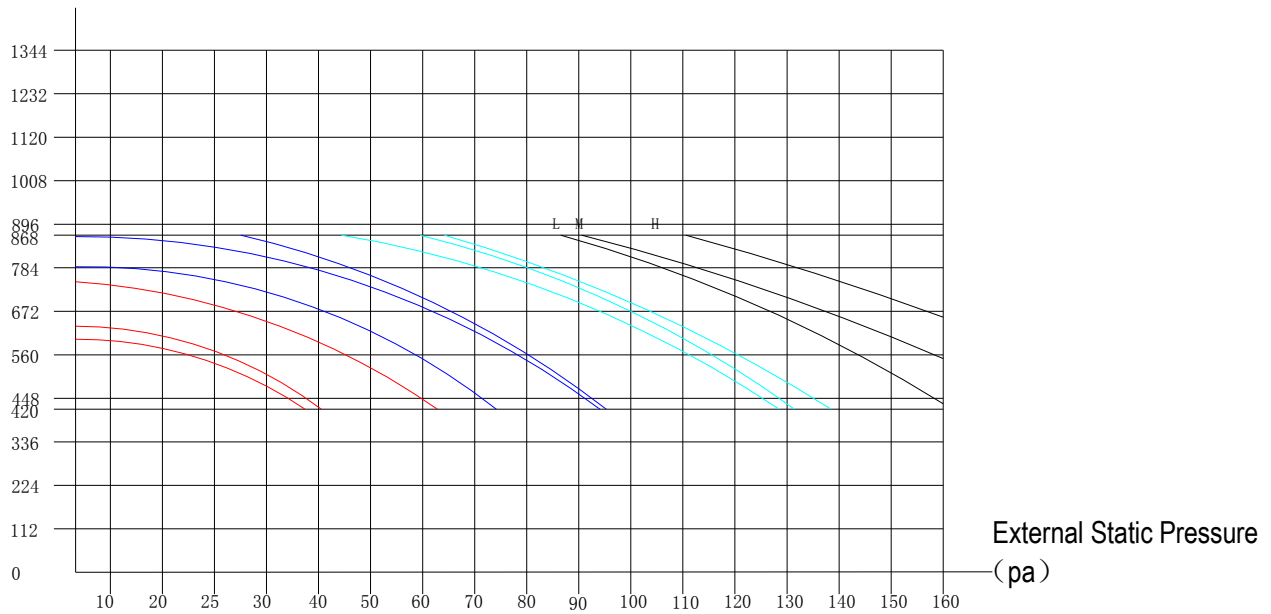

42QSS060R8S*

Air flow rate (L/S)
(with filter)

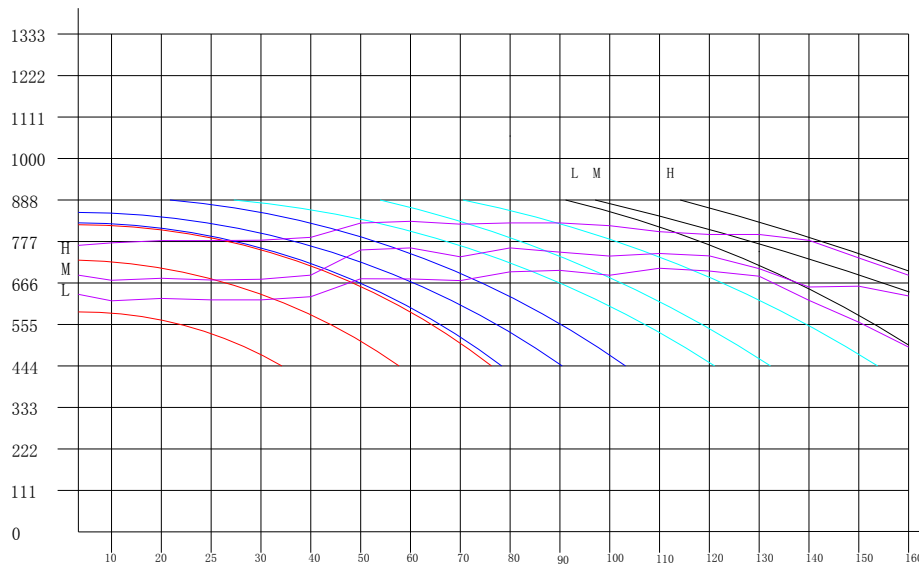

- SP0
- SP1
- SP2
- SP3
- SP4

External Static Pressure
(pa)

Air flow rate (L/S)
(no filter)

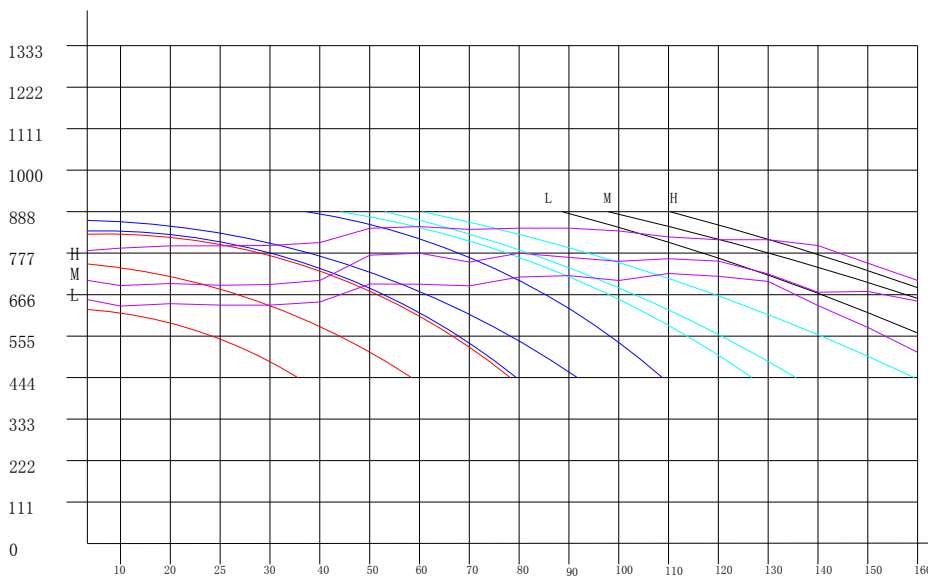

External Static Pressure
(pa)

6. Electric Characteristics

Model	Indoor Unit				Power Supply
	Hz	Voltage	Min.	Max.	MFA
42QSS018R8S*	50	220-240V	198V	254V	/
42QSS024R8S*	50	220-240V	198V	254V	/
42QSS036R8S*	50	220-240V	198V	254V	/
42QSS048R8S*	50	220-240V	198V	254V	/
42QSS060R8S*	50	220-240V	198V	254V	/

Note:





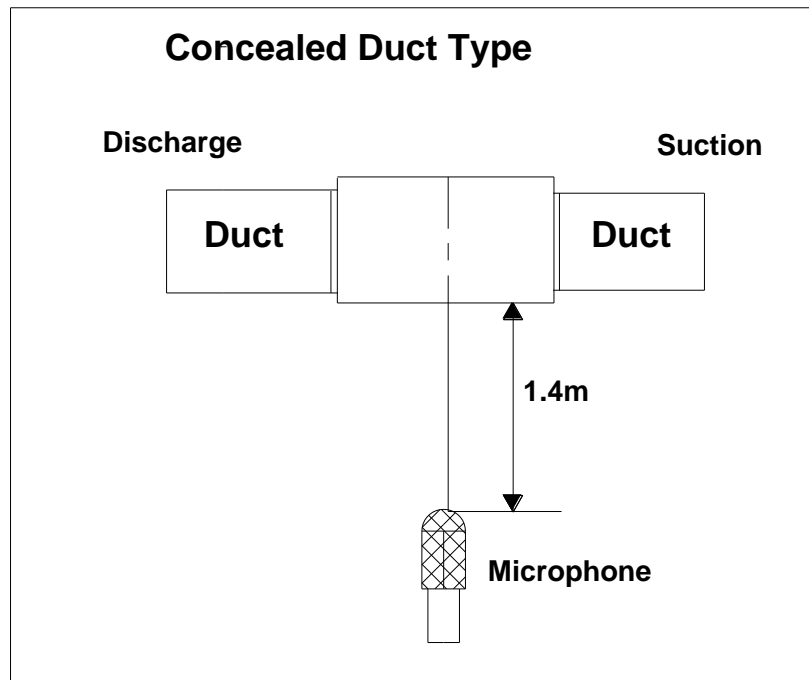



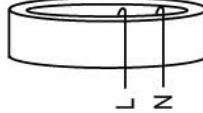

MFA: Max. Fuse Amps. (A)

7. Sound Levels



Model	Sound Power dB(A)	Noise level dB(A)		
		H	M	L
42QSS018R8S*	60	42	40	38
42QSS024R8S*	63	42	40	38
42QSS036R8S*	65	45	42	39
42QSS048R8S*	67	51	49	47
42QSS060R8S*	71	54	52	50

8. Accessories

	Name	Shape	Quantity
Tubing & Fittings	Soundproof / insulation sheath		2
	Drainpipe Fittings (for cooling & heating)	Drain joint	
	Seal ring		1
EMC & It's Fitting (for some models)	Magnetic ring (twist the electric wires L and N around the magnetic ring to five circles)		1
Wired controller & Its Frame	Wired controller		1
	Owner' s manual of wired controller		1
	Wired controller installation manual		1
Others	Owner' s manual		1
	Installation manual		1
	Connecting wire for display (2m)		1(on some models)
	Cord protection rubber ring		1(on some models)

9. The Specification of Power

Model(Btu/h)		18000~24000	36000	36000	48000~60000
POWER	Phase	1-phase	1-phase	3-phase	3-phase
	Frequency and Voltage	220-240V, 50Hz	220-240V, 50Hz	380-415V, 50Hz	380-415V, 50Hz
	POWER WIRING (mm ²)	3×2.5	3×4.0	5×2.5	5×2.5
CIRCUIT BREAKER/Fuse (A)		30/20	40/30	30/20	30/25
Indoor/Outdoor Connecting Wiring (Weak Electric Signal) (mm ²)		2×0.2	2×0.2	2×0.2	2×0.2
Indoor/Outdoor Connecting Wiring (Strong Electric Signal) (mm ²)		3×1.0	3×1.0	3×1.0	3×1.0

10. Field Wiring

42QSS018R8S*, 42QSS024R8S*, 42QSS036R8S*, 42QSS048R8S*,
42QSS060R8S*

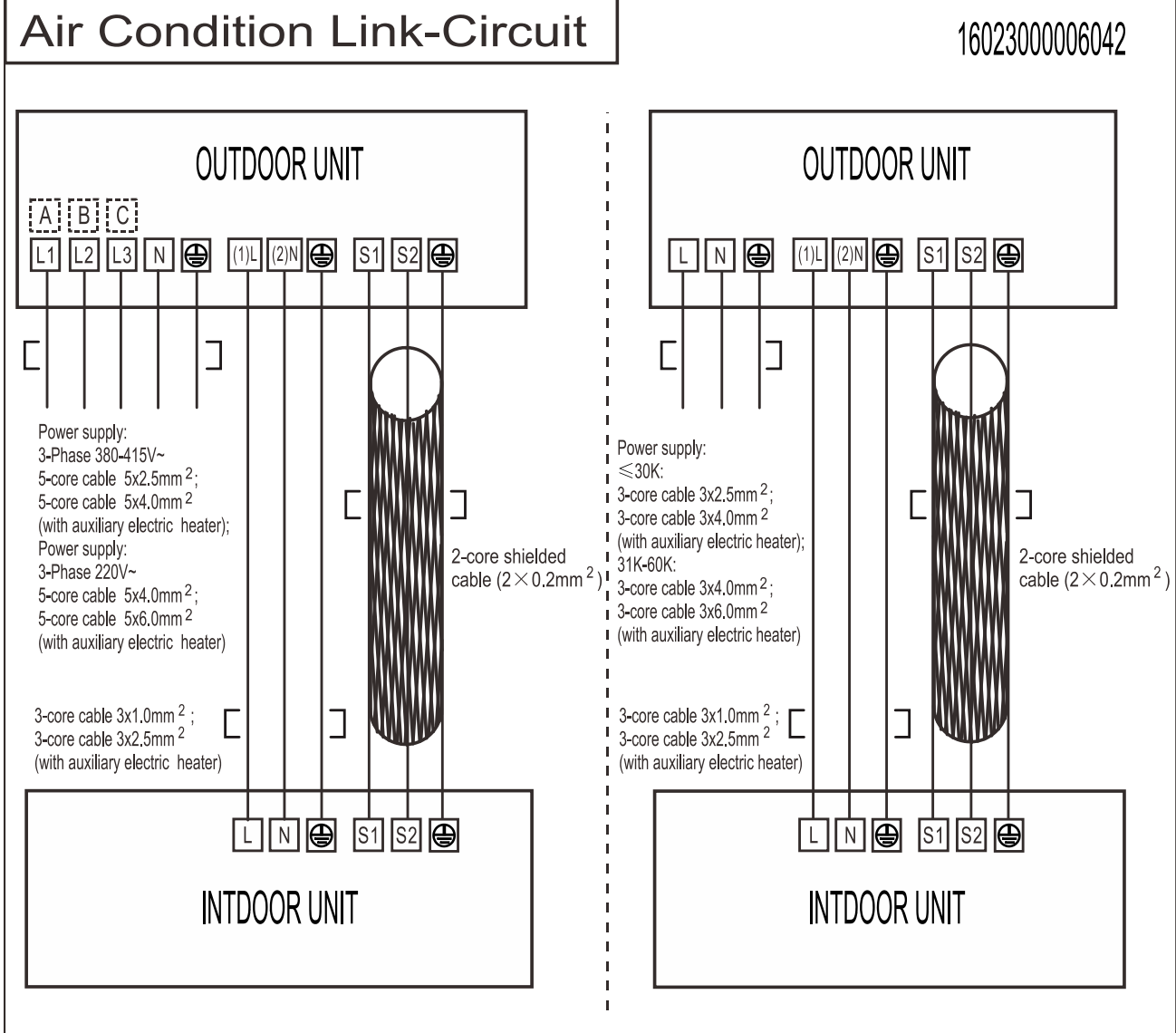

Ceiling & Floor Type

1. Features	42
2. Dimensions	43
3. Service Space	44
4. Wiring Diagrams	45
5. Electric Characteristics.....	47
6. Sound Levels	47
7. Air Velocity and Temperature Distributions (Reference Data)	48
8. Accessories	54
9. The Specification of Power	54
10. Field Wiring.....	55

1. Features

1.1. New design, more modern and elegant appearance.



1.2. Convenient installation

- The ceiling type can be easily installed into a corner of the ceiling even if the ceiling is very narrow
- It is especially useful when installation of an air conditioner in the center of the ceiling is impossible due to a structure such as one lighting.

1.3. Two direction auto swing (vertical & horizontal) and wide angle air flow,

- Air flow directional control minimizes the air resistance and produces wider air flow to vertical direction.
- The range of horizontal air discharge is widened which secures wider air flow distribution to provide more comfortable air circulation no matter where the unit is set up

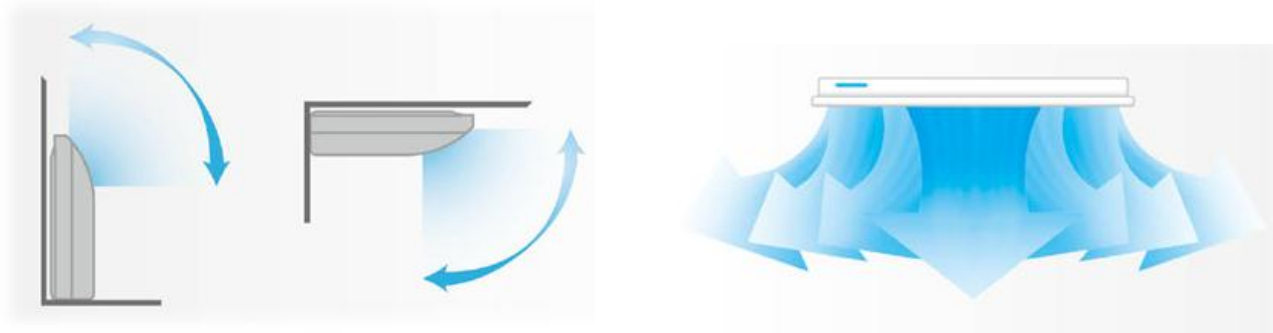

1.4. Three level fan speed, more humanism design, meets different air-supply requirement.

1.5. New foam drain pan with plastic-spraying inner surface



1.6. Easy operation.

1.7. Remote control and optional wired control method.

2. Dimensions

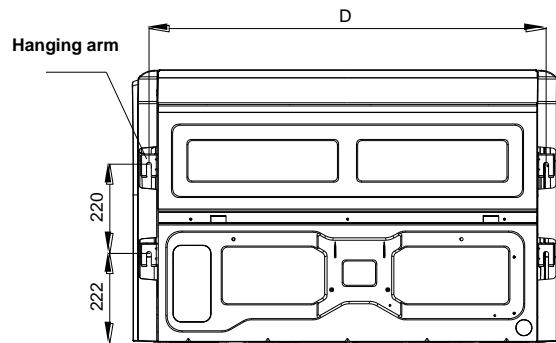
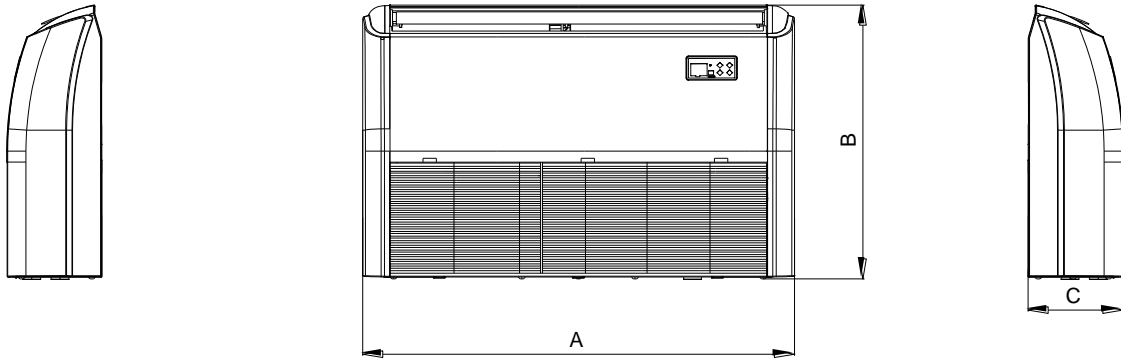
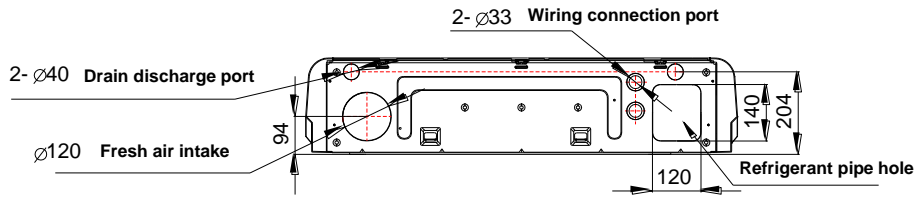

Capacity (KBtu/h)	A	B	C	D
18/24	1068	675	235	983
36/48/55	1650	675	235	1565

3. Service Space

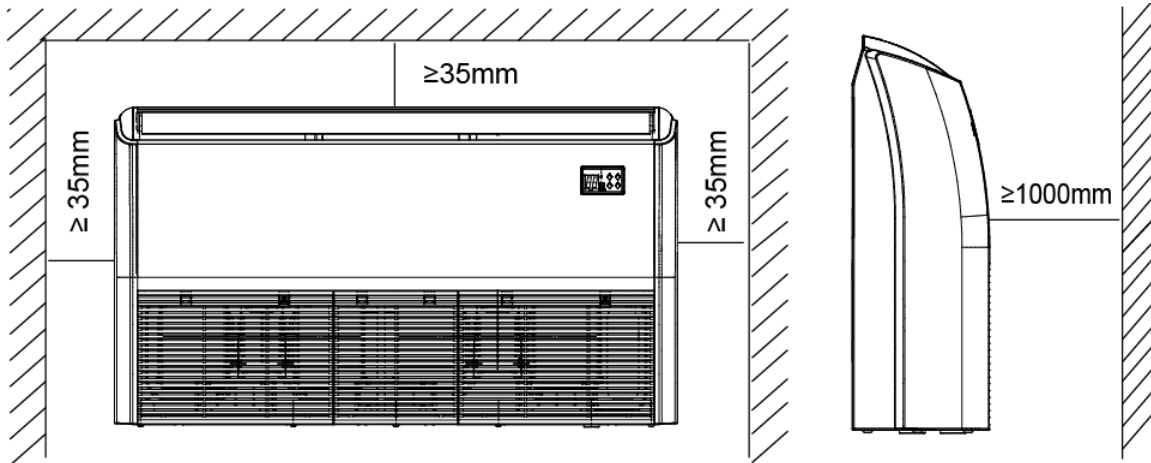

4. Wiring Diagrams

42QZL018D8S-1

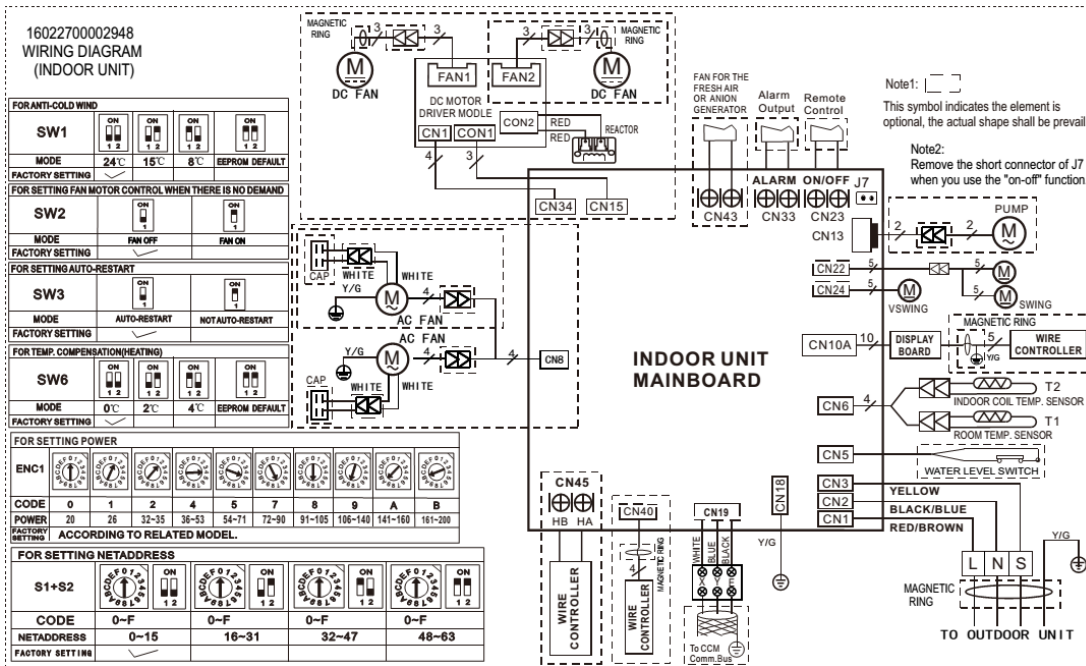

42QZL024R8S*

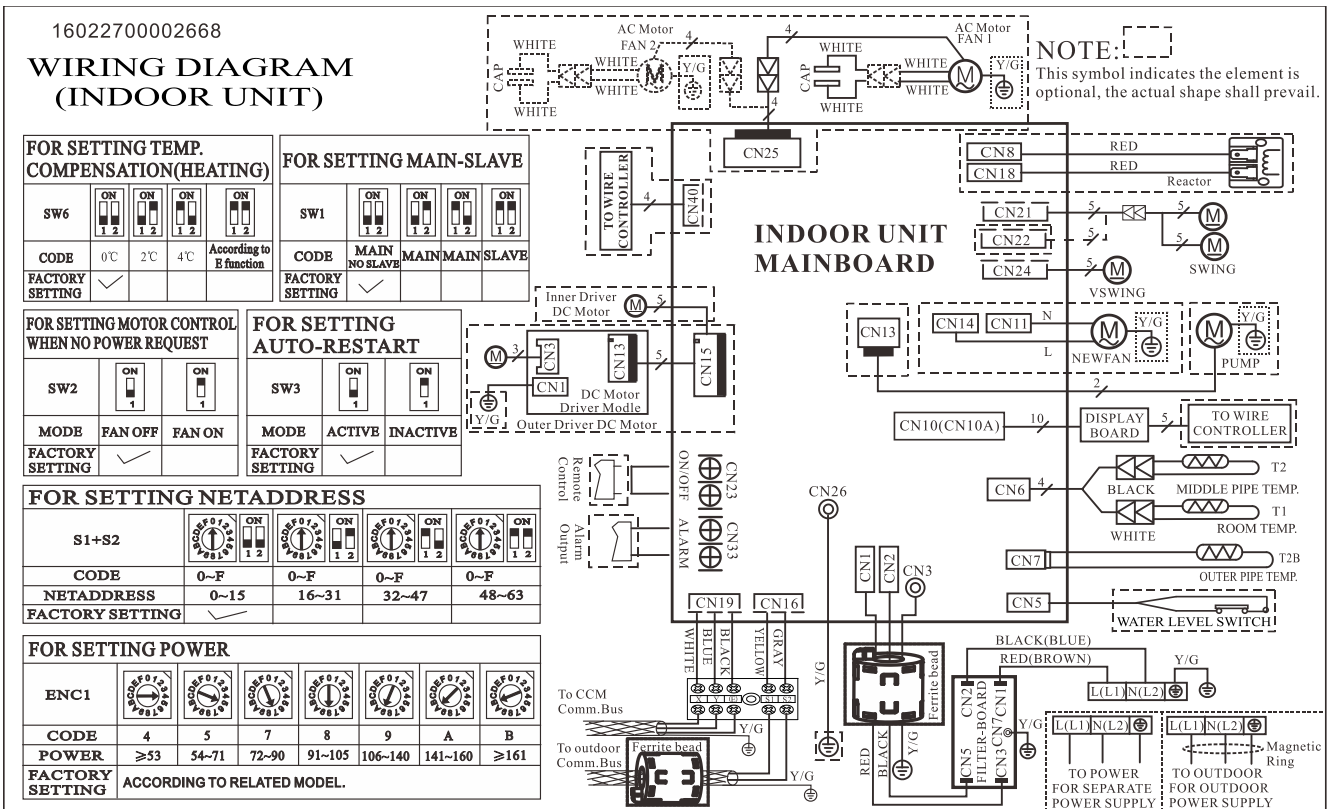

42QZL036R8S*, 42QZL048R8S*, 42QZL060R8S*

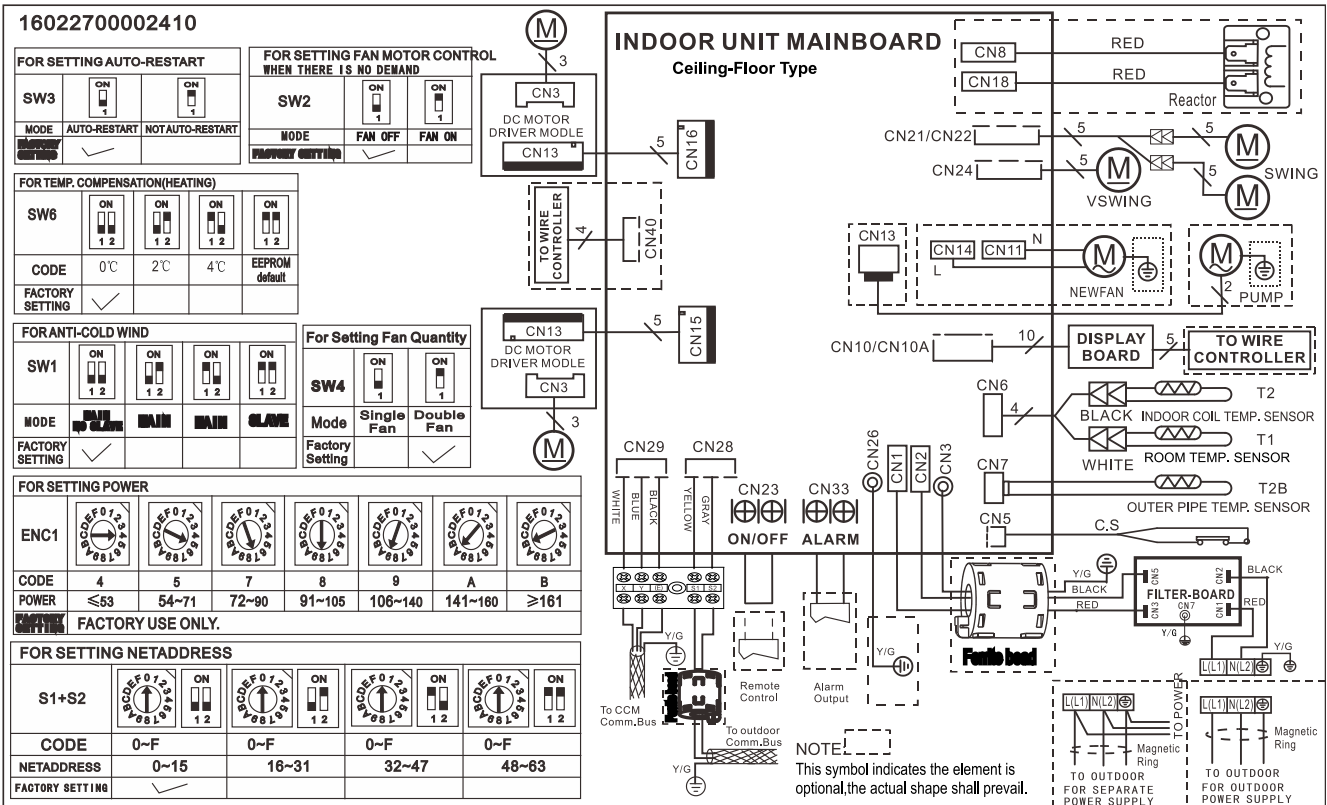

5. Electric Characteristics

Model	Indoor Units				Power Supply
	Hz	Voltage	Min.	Max.	MFA
42QZL018R8S*	50	220-240V	198V	254V	/
42QZL024R8S*	50	220-240V	198V	254V	/
42QZL036R8S*	50	220-240V	198V	254V	/
42QZL048R8S*	50	220-240V	198V	254V	/
42QZL060R8S*	50	220-240V	198V	254V	/

Note:

MFA: Max. Fuse Amps. (A)

6. Sound Levels

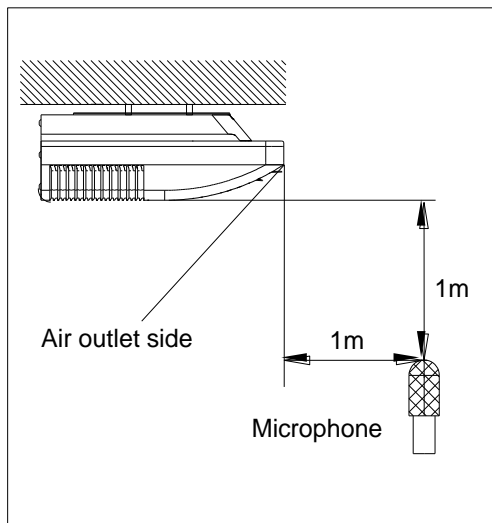

Ceiling

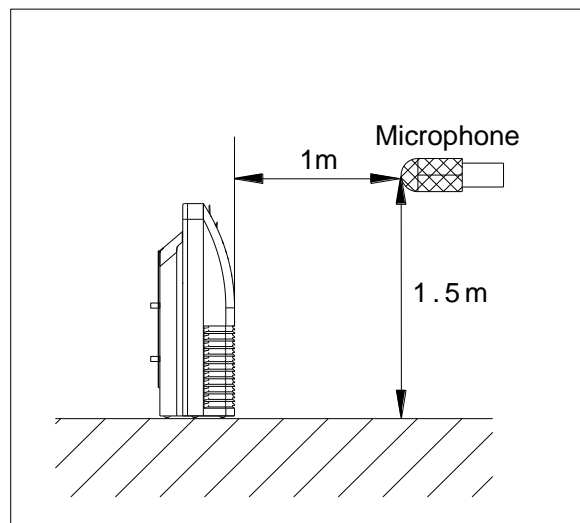

Floor

Model	Sound Power dB (A)	Noise level dB(A)		
		H	M	L
42QZL018R8S*	57	45	40	37
42QZL024R8S*	62	49	46	41
42QZL036R8S*	63	50	46	42
42QZL048R8S*	66	52	48	43
42QZL060R8S*	68	54	47	43

7. Air Velocity and Temperature Distributions (Reference Data)

Model: 42QZL018R8S*, 42QZL024R8S*

Ceiling installation:

Discharge angle 17°

Cooling airflow velocity distribution

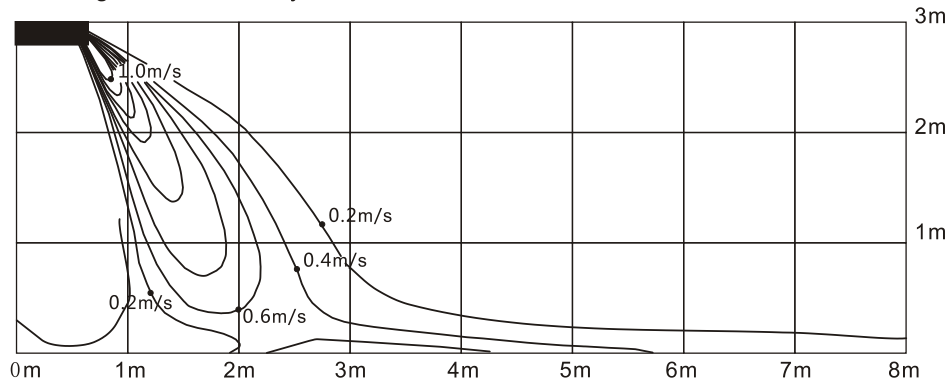

Cooling temperature distribution

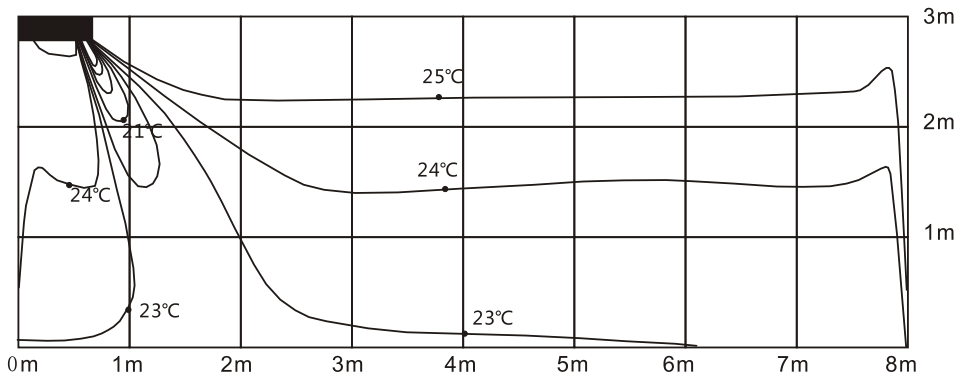

Discharge angle 50°

Heating airflow velocity distribution

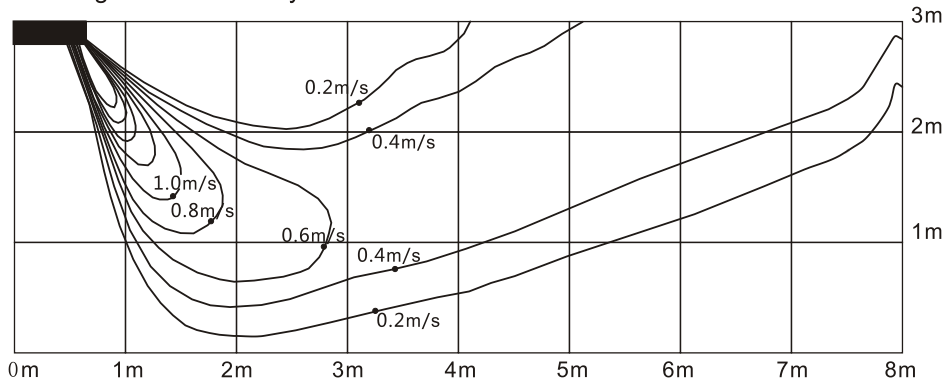

Heating temperature distribution

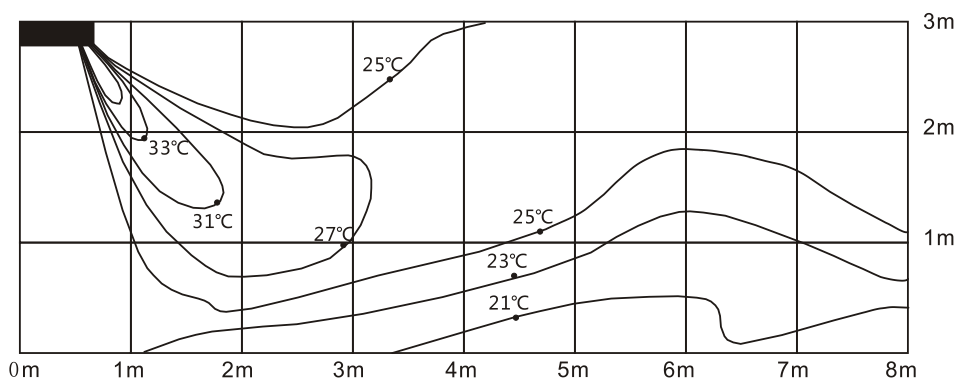

Floor installation:

Discharge angle 17°

Cooling airflow velocity distribution

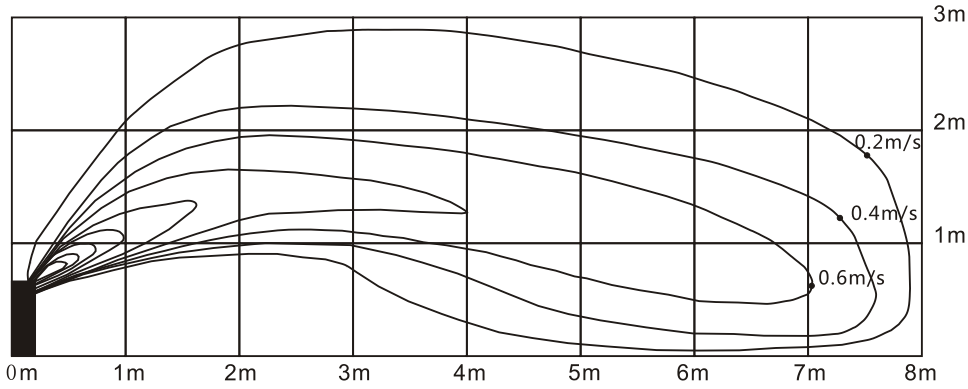

Cooling temperature distribution

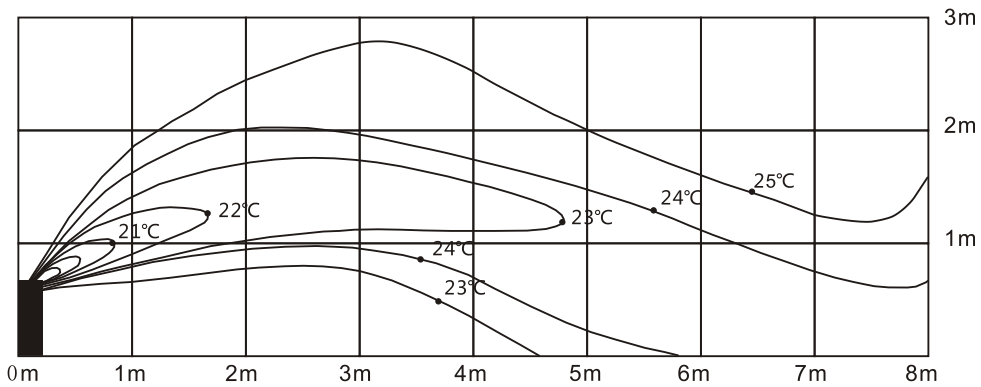

Discharge angle 50°

Heating airflow velocity distribution

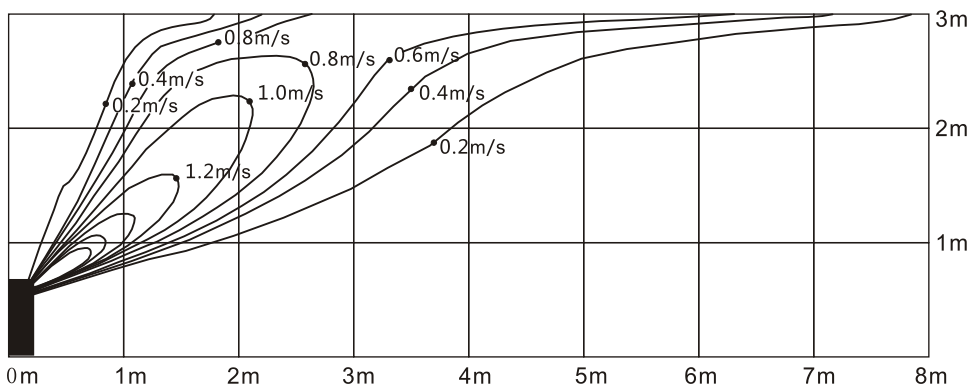

Heating temperature distribution

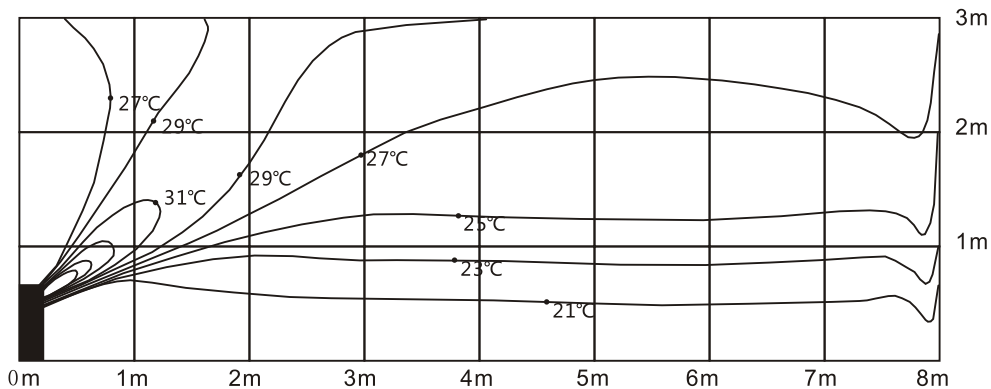

Model: 42QZL036R8S*

Ceiling installation:

Discharge angle 17°

Cooling airflow velocity distribution

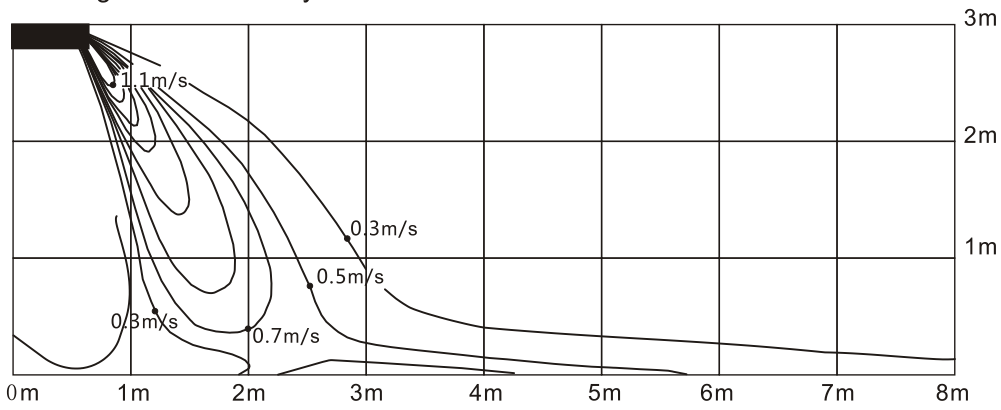

Cooling temperature distribution

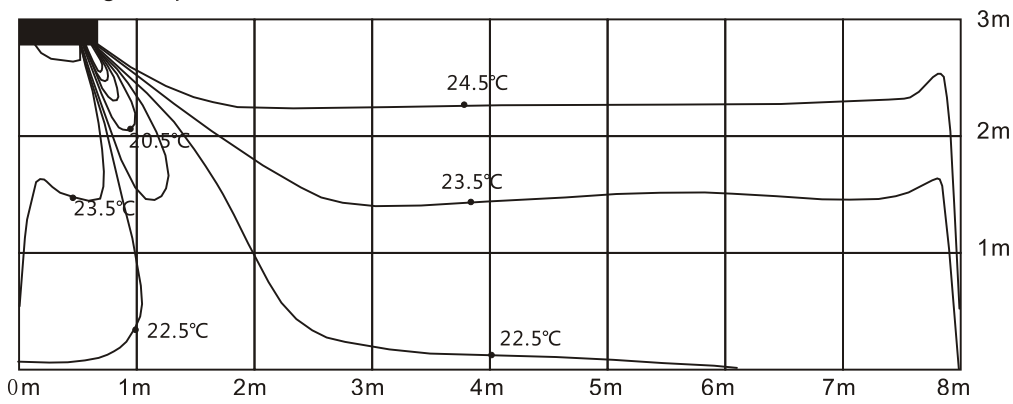

Discharge angle 50°

Heating airflow velocity distribution

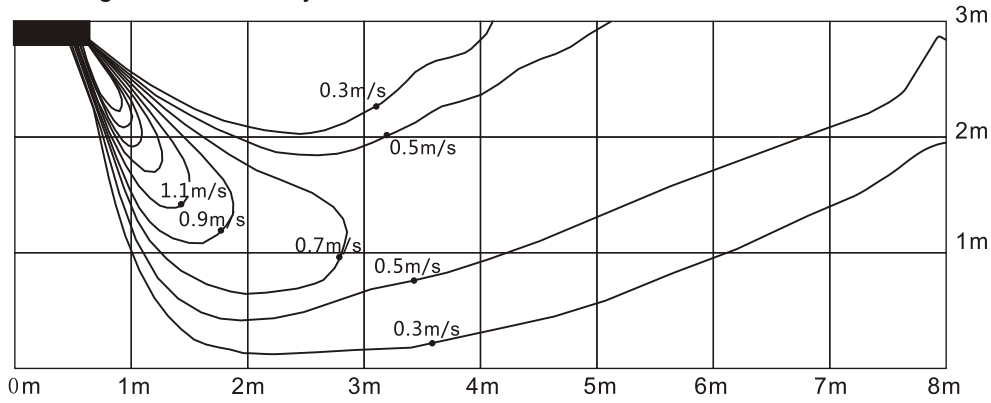

Heating temperature distribution

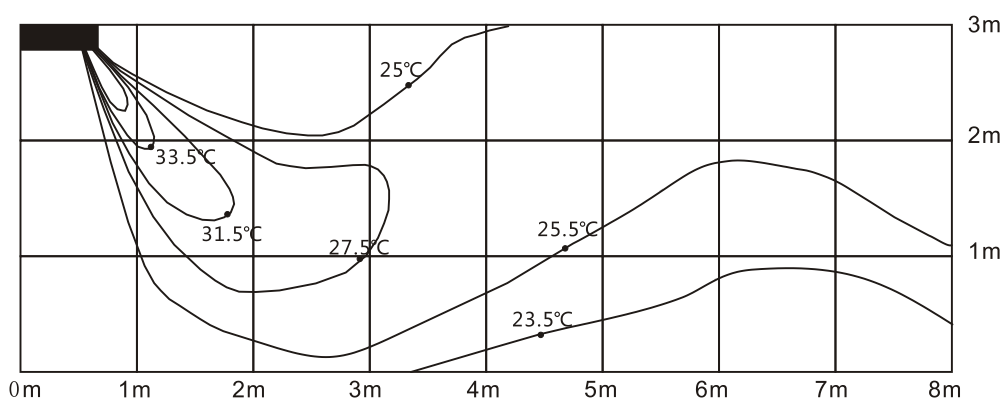

Floor installation:

Discharge angle 17°

Cooling airflow velocity distribution

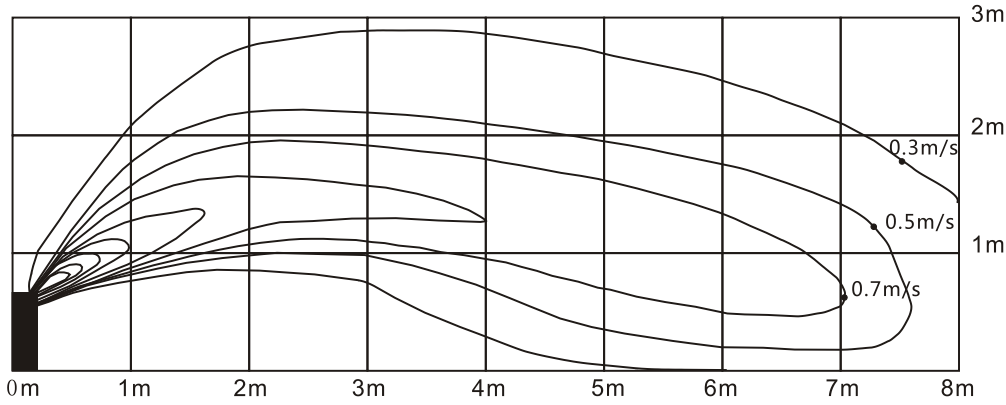

Cooling temperature distribution

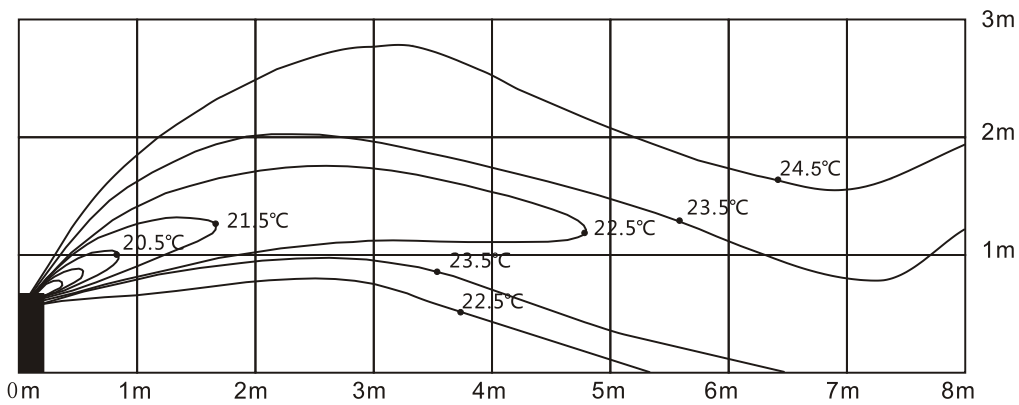

Discharge angle 50°

Heating airflow velocity distribution

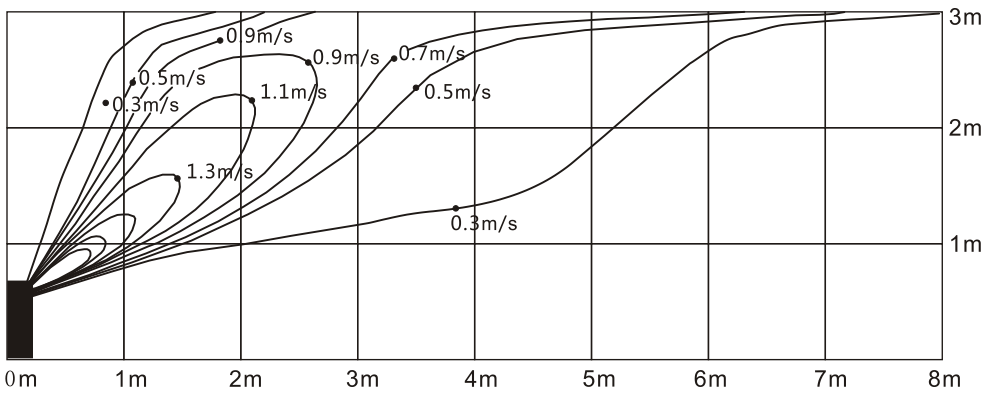

Heating temperature distribution

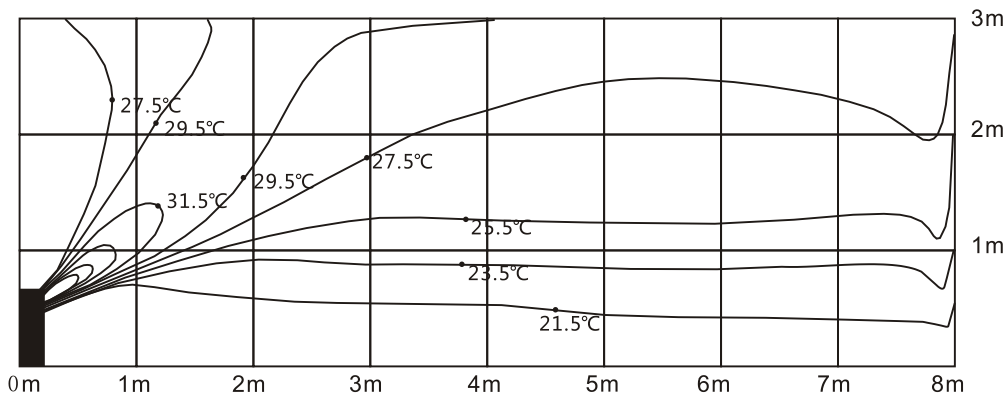

Model: 42QZL048R8S*, 42QZL060R8S*

Ceiling installation:

Discharge angle 17°

Cooling airflow velocity distribution

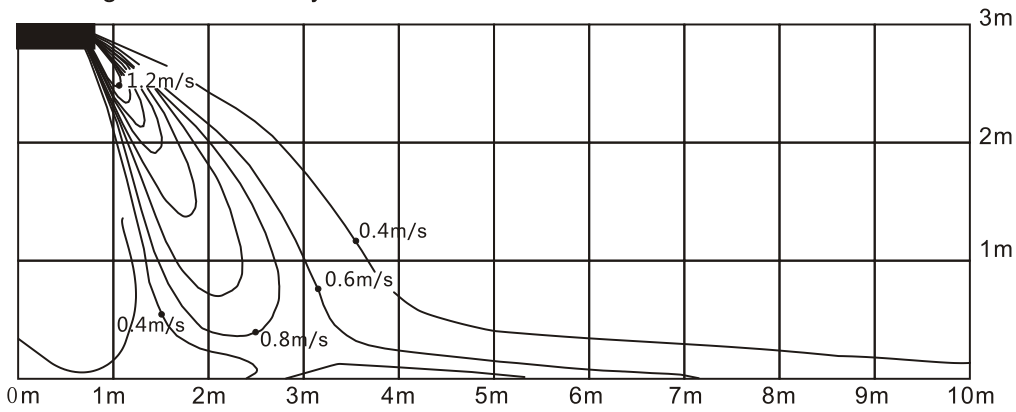

Cooling temperature distribution

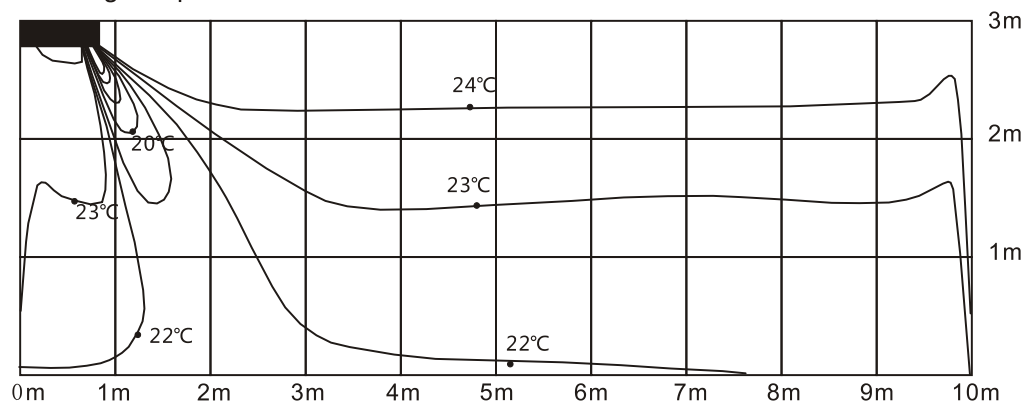

Discharge angle 50°

Heating airflow velocity distribution

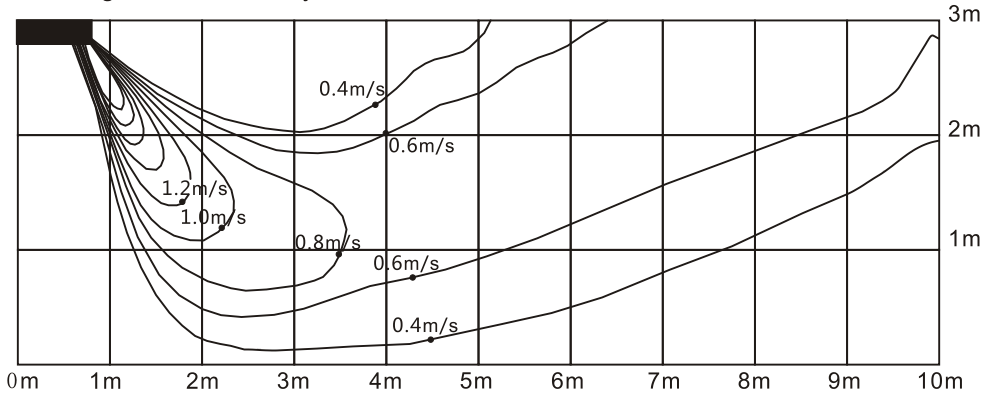

Heating temperature distribution

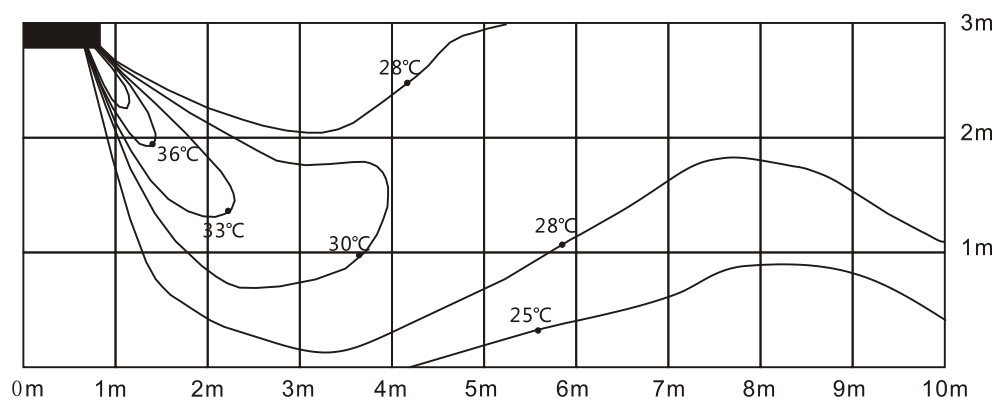

Floor installation:

Discharge angle 17°

Cooling airflow velocity distribution

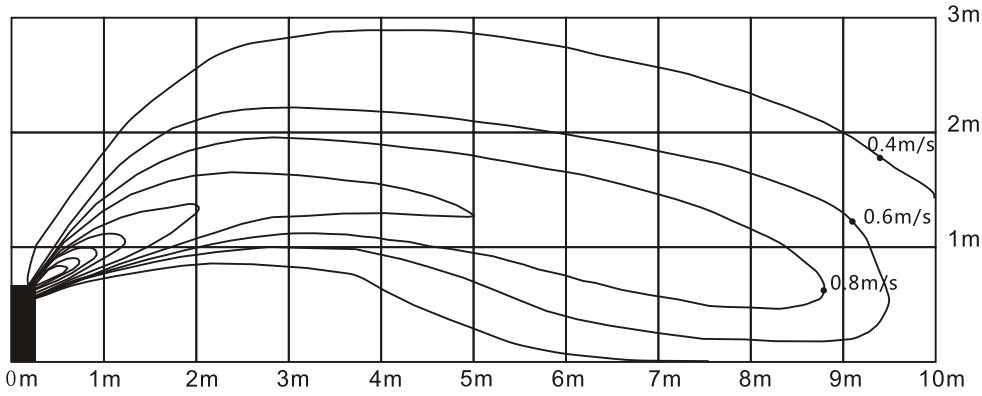

Cooling temperature distribution

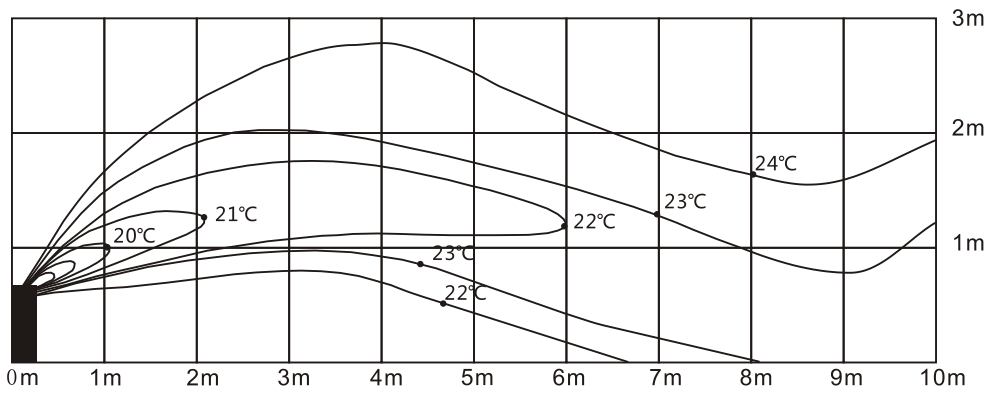

Discharge angle 50°



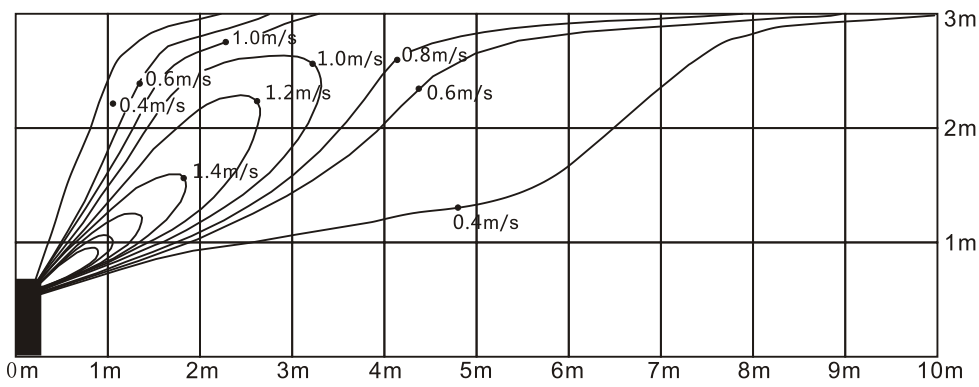

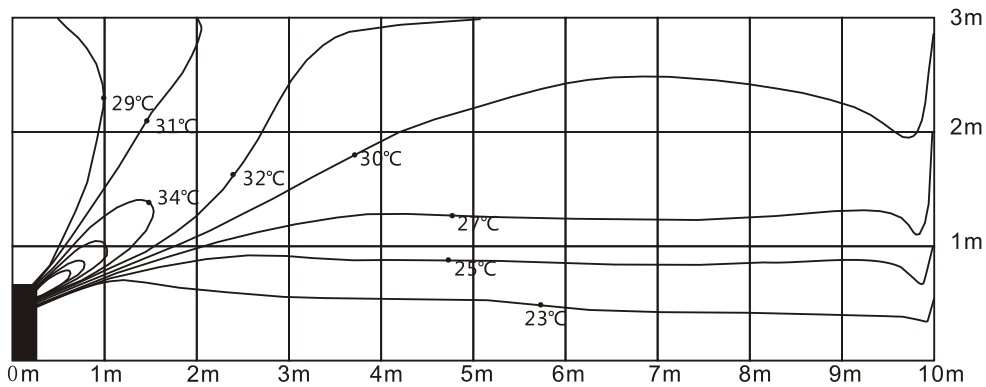

Heating airflow velocity distribution



Heating temperature distribution

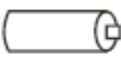

8. Accessories

	Name	Shape	Quantity
Remote controller & Its holder(The product you have might not be provided the following accessories)	1. Remote controller		1
	2. Remote controller holder		1
	3. Mounting screw (ST2.9x10-C-H)		2
	4. Alkaline dry batteries (AM4)		2
Others	5. Owner's manual		1
	6. Installation manual		1
	7. Remote controller manual		1

9. The Specification of Power

Model(Btu/h)		18000~24000	36000	36000	48000~60000
POWER	Phase	1-phase	1-phase	3-phase	3-phase
	Frequency and Voltage	220-240V, 50Hz	220-240V, 50Hz	380-415V, 50Hz	380-415V, 50Hz
	POWER WIRING (mm ²)	3x2.5	3x4.0	5x2.5	5x2.5
CIRCUIT BREAKER/Fuse (A)		30/20	40/30	30/20	30/25
Indoor/Outdoor Connecting Wiring (Weak Electric Signal) (mm ²)		2x0.2	2x0.2	2x0.2	2x0.2
Indoor/Outdoor Connecting Wiring (Strong Electric Signal) (mm ²)		3x1.0	3x1.0	3x1.0	3x1.0

10. Field Wiring

42QZL018R8S*, 42QZL024R8S*, 42QZL036R8S*, 42QZL048R8S*, 42QZL060R8S*

Air Condition Link-Circuit

16023000006042

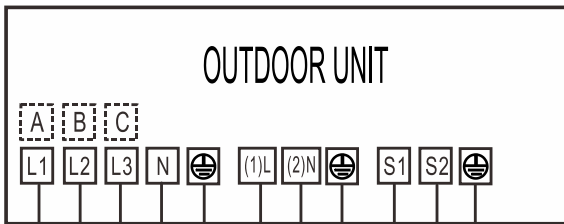

Power supply:
3-Phase 380-415V~
5-core cable 5x2.5mm²;
5-core cable 5x4.0mm²
(with auxiliary electric heater);
Power supply:
3-Phase 220V~
5-core cable 5x4.0mm²;
5-core cable 5x6.0mm²
(with auxiliary electric heater)

3-core cable 3x1.0mm²;
3-core cable 3x2.5mm²
(with auxiliary electric heater)

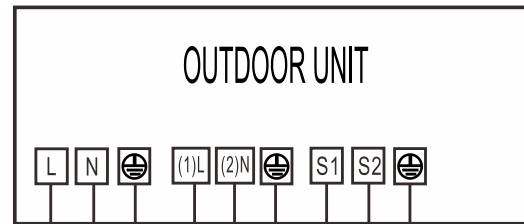
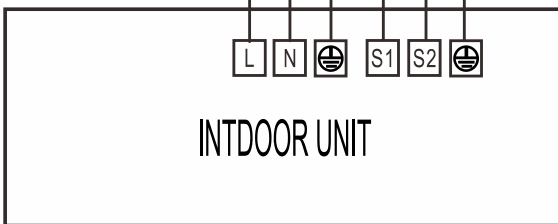
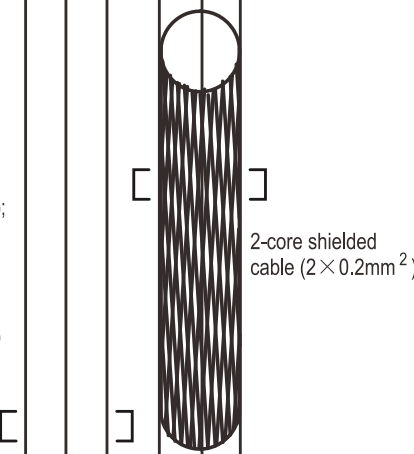

Power supply:
≤30K:
3-core cable 3x2.5mm²;
3-core cable 3x4.0mm²
(with auxiliary electric heater);
31K-60K:
3-core cable 3x4.0mm²;
3-core cable 3x6.0mm²
(with auxiliary electric heater)

3-core cable 3x1.0mm²;
3-core cable 3x2.5mm²
(with auxiliary electric heater)

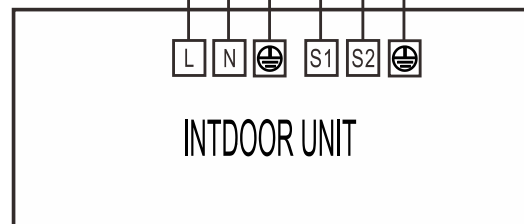
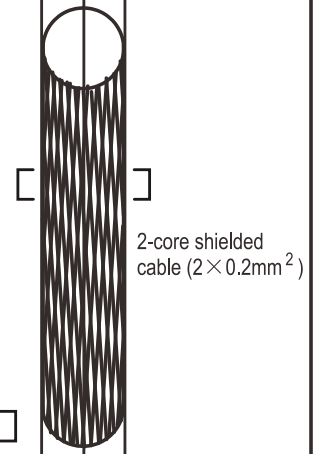

Part 3

Outdoor Units

1. Dimensions.....	57
2. Service Space.....	59
3. Wiring Diagrams	60
4. Piping Diagrams.....	65
5. Electric Characteristics	66
6. Operation Limits	67
7. Sound Levels.....	68

1. Dimensions

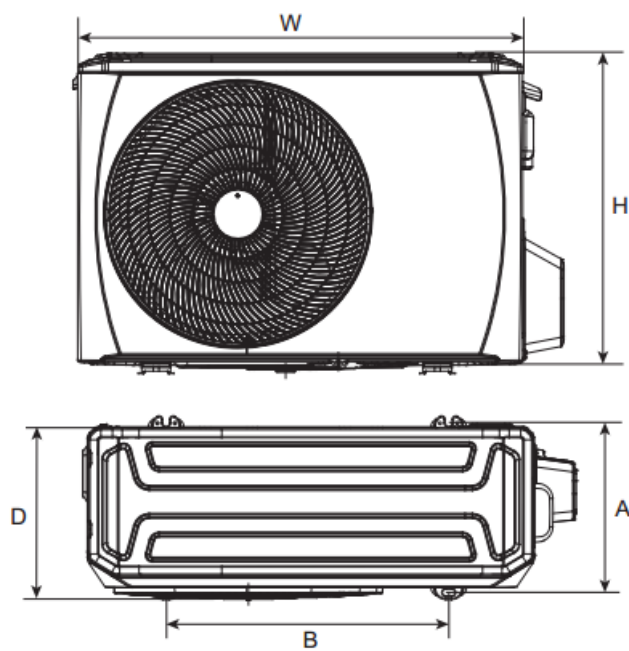

Model	Unit: mm					
	W	D	H	W1	A	B
38QUS018R8S*	800	333	554	870	514	340
38QUS024R8S*	845	363	702	914	540	350
38QUS036R8S*	946	410	810	1030	673	403
38QUS036R8T*	946	410	810	1030	673	403

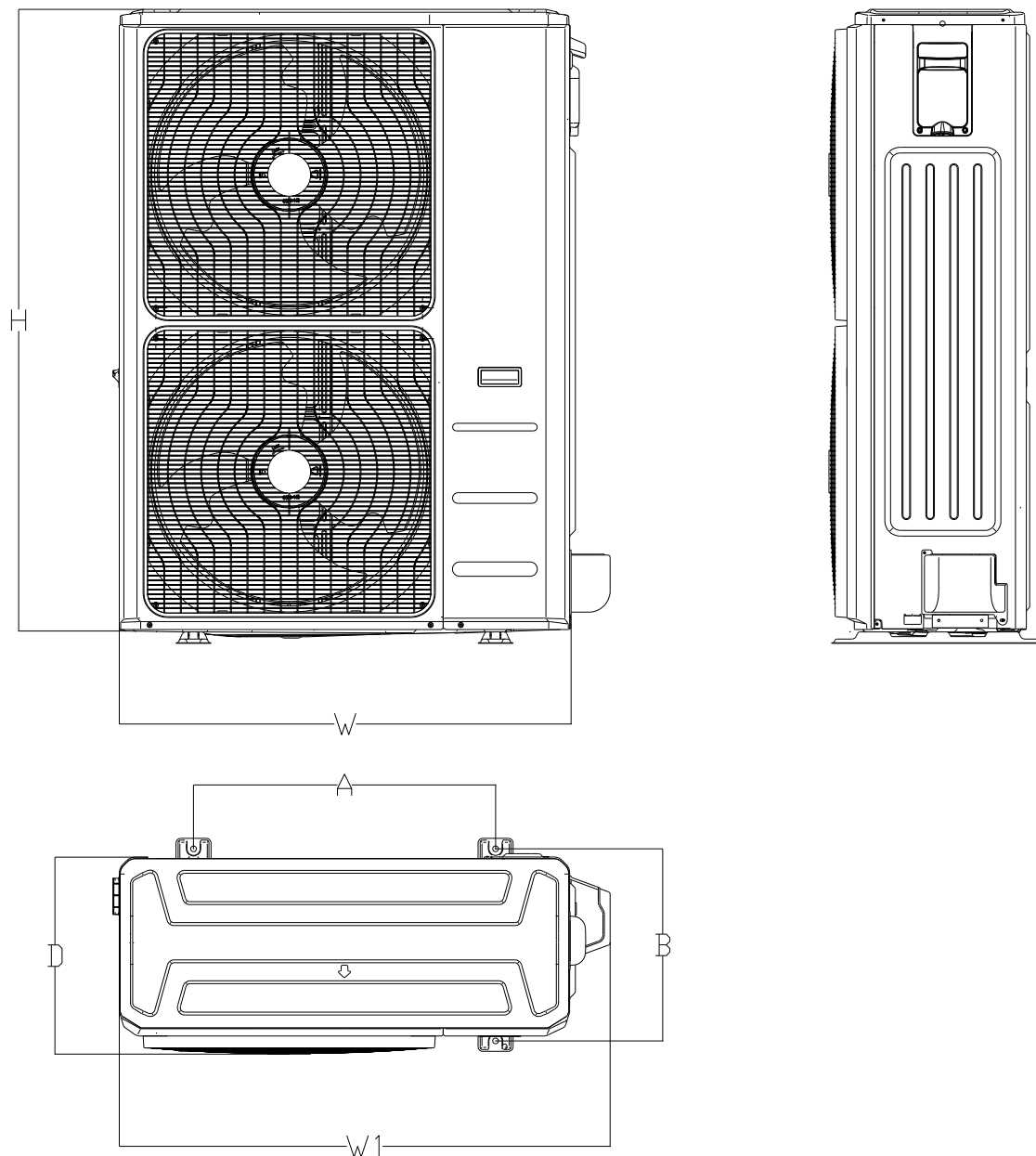

Model	Unit: mm					
	W	D	H	W1	A	B
38QUS048R8T*	952	415	1333	1045	634	404
38QUS060R8T*	952	415	1333	1045	634	404

2. Service Space

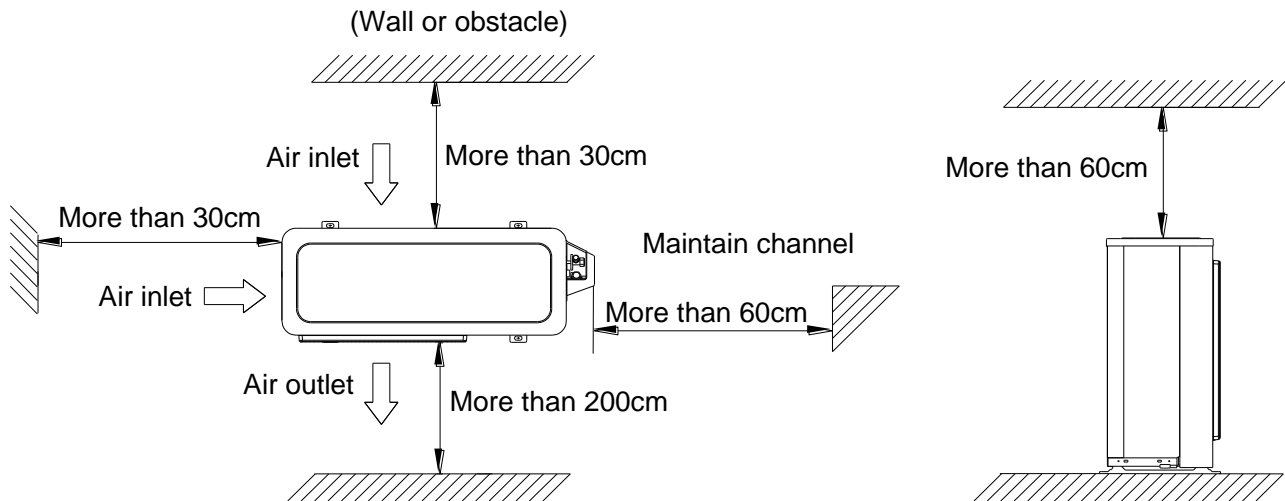

3. Wiring Diagrams

38QUS018R8S*

16022000026369

Notes: - - - - -

This symbol indicates the element is optional, the actual shape shall prevail.

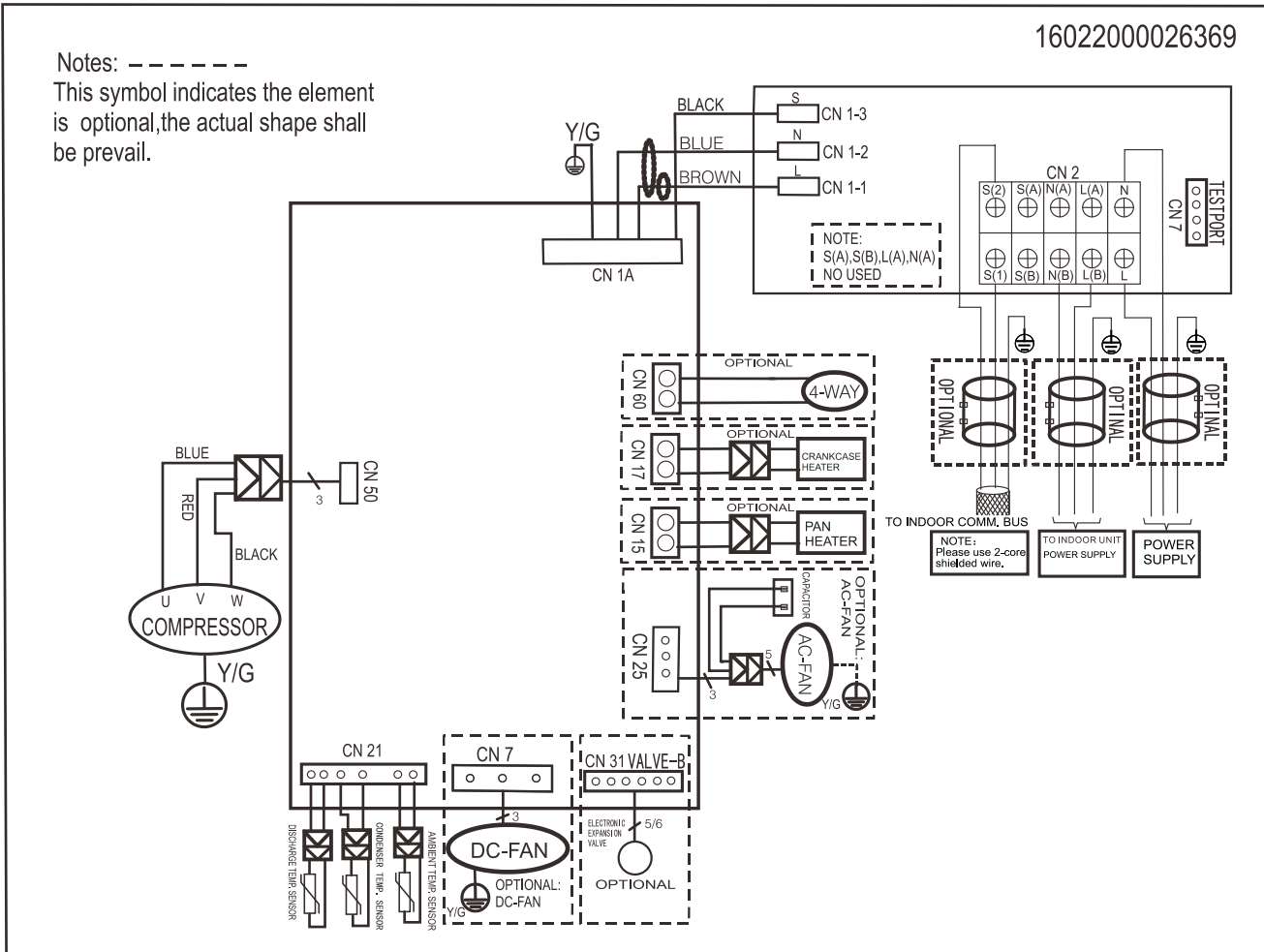

38QUS024R8S*

16022500003723

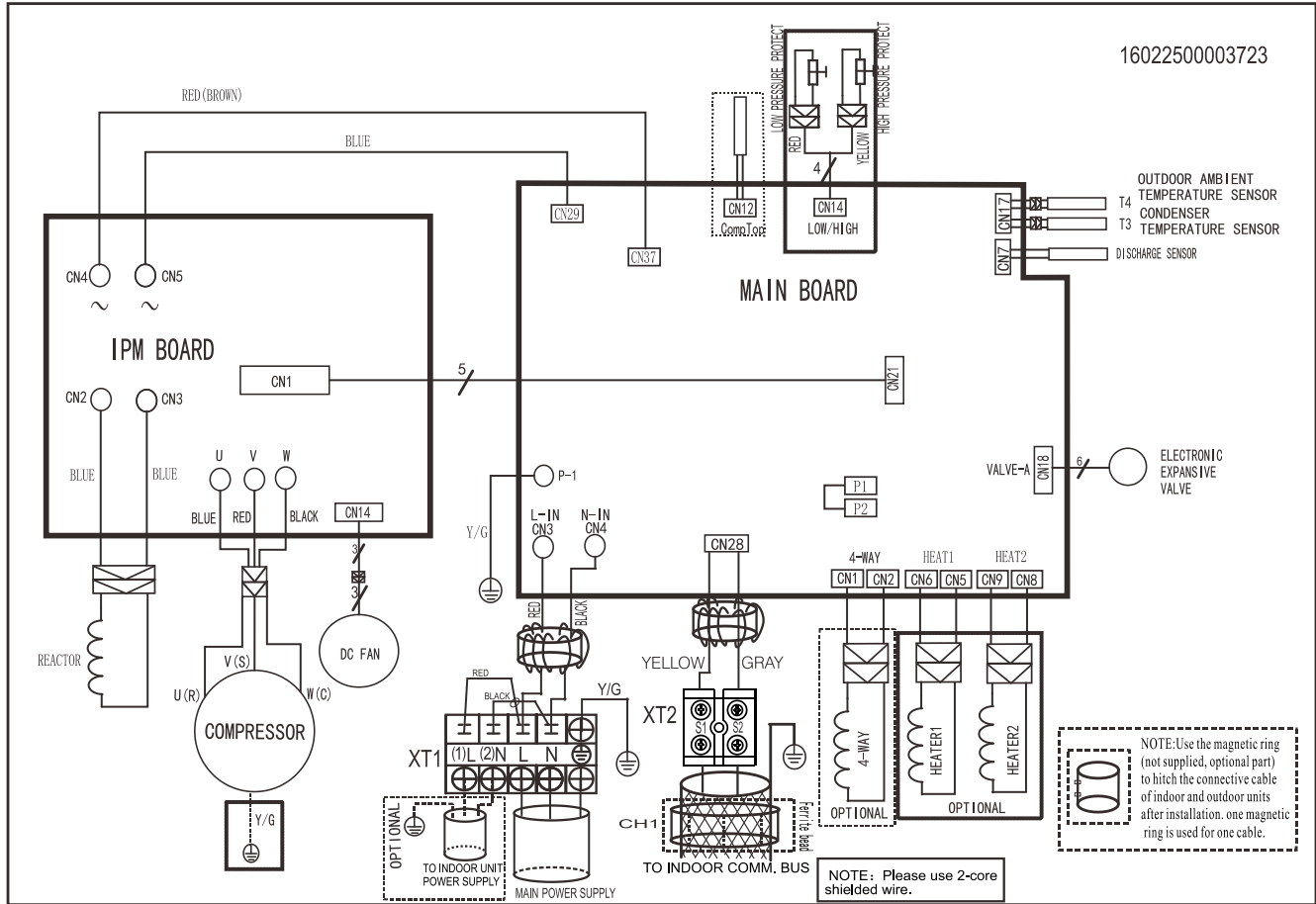

38QUS036R8S*

16022700002412

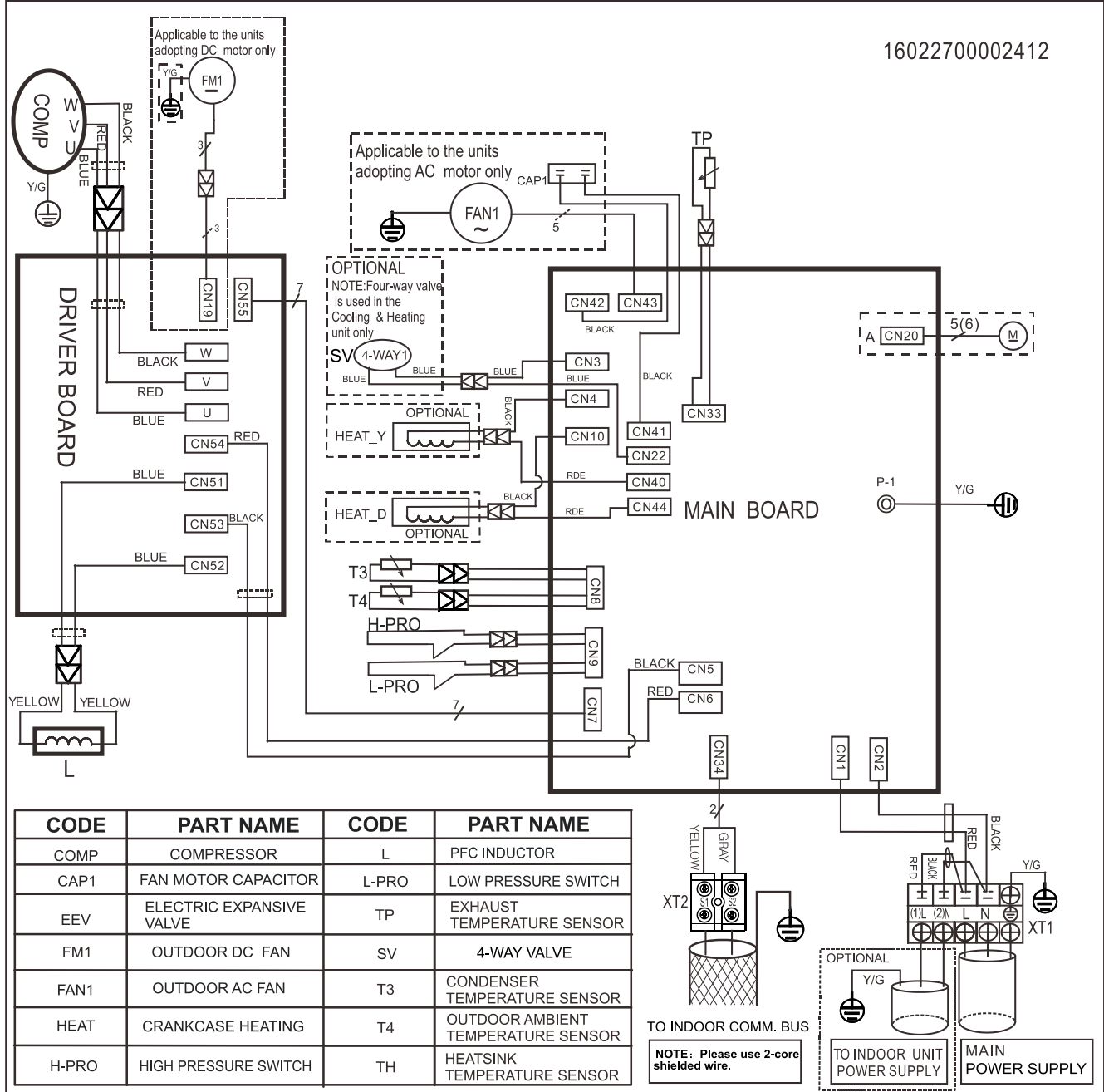

38QUS036R8T*

WIRING DIAGRAM (OUTDOOR UNIT)

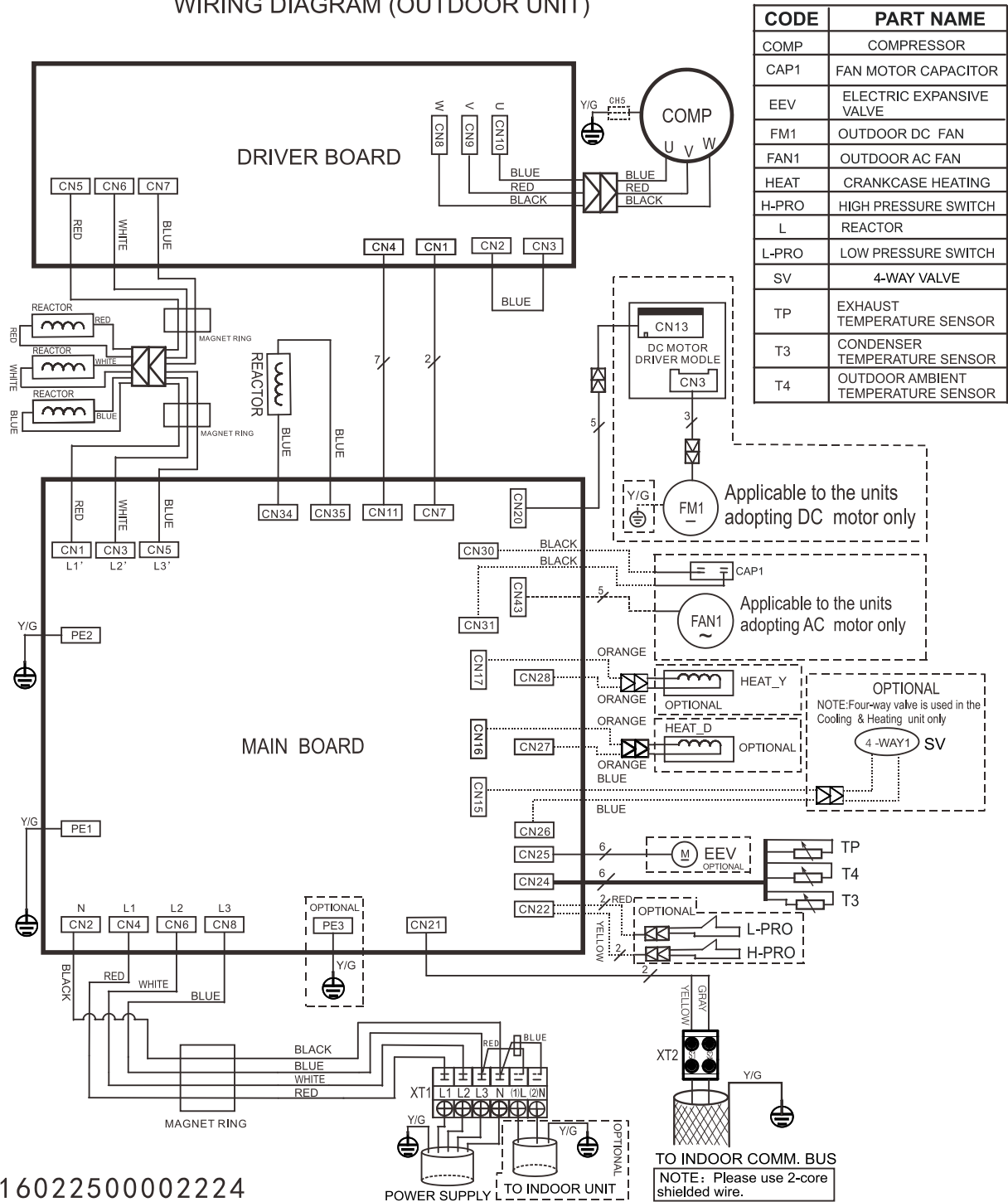

38QUS048R8T*, 38QUS060R8T*

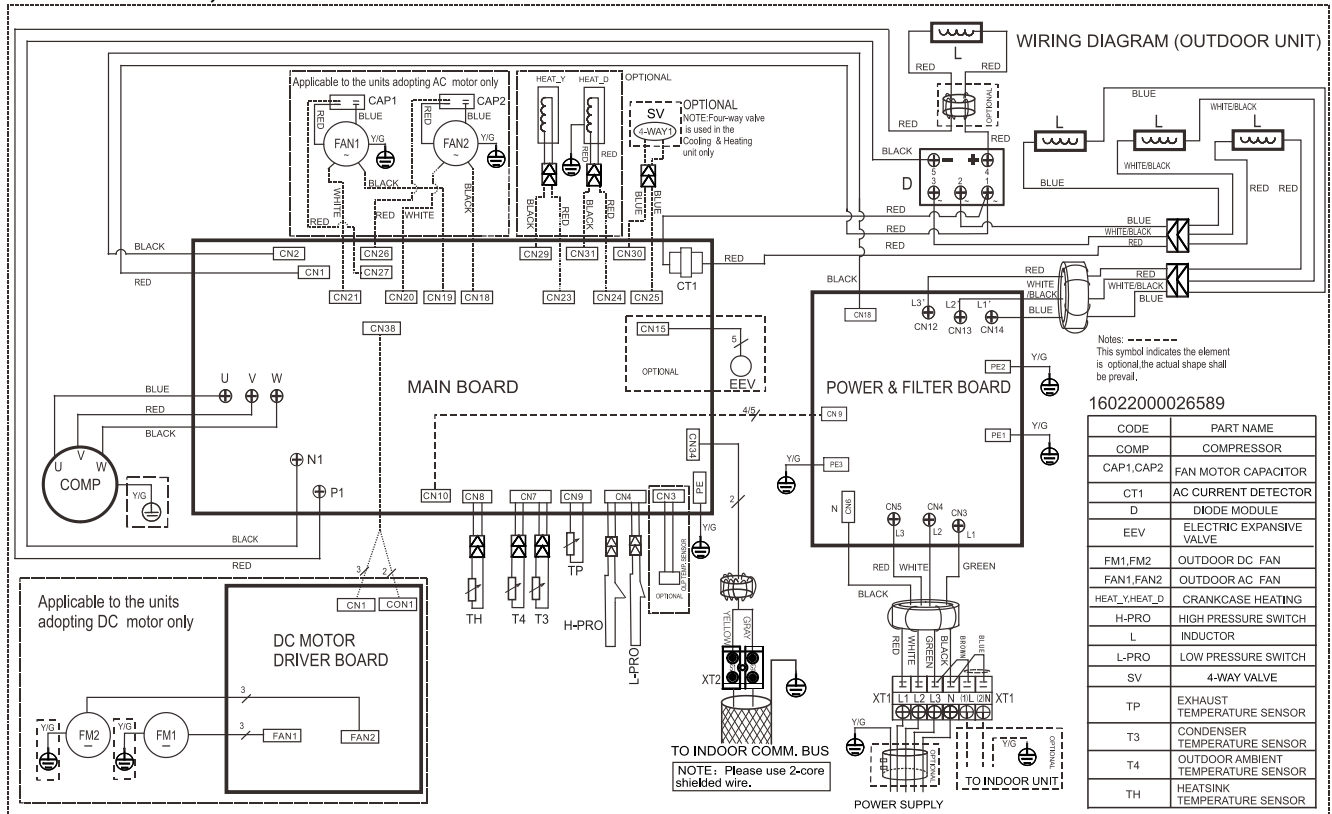

4. Piping Diagrams

38QUS018R8S*, 38QUS024R8S*

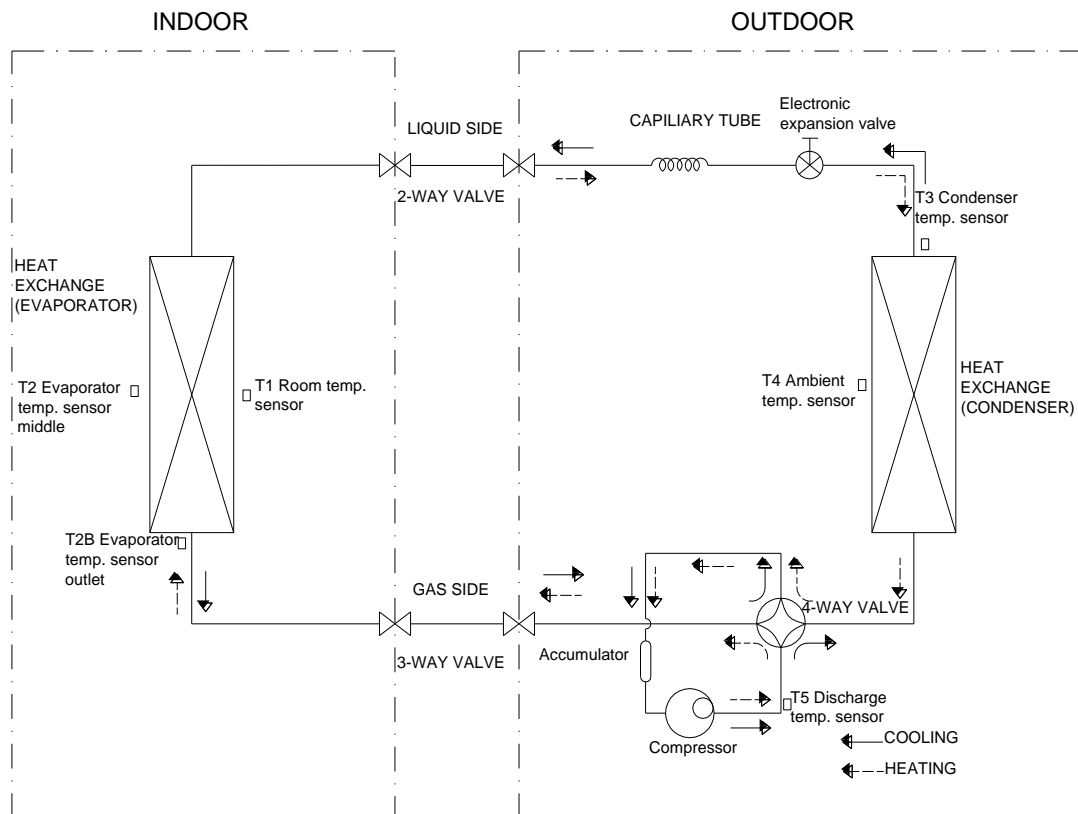

For 38QUS024R8S*, there is no accumulator.

38QUS036R8S*,
INDOOR

38QUS036R8T*,

38QUS048R8T*,
OUTDOOR

38QUS060R8T*

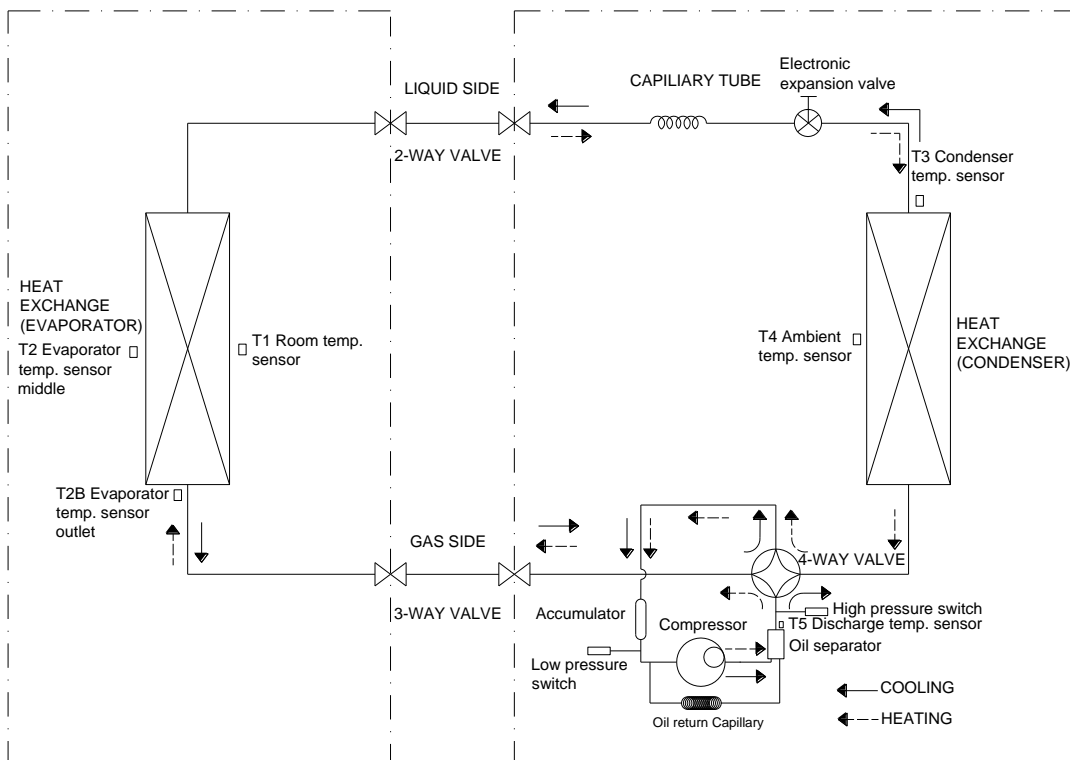

5. Electric Characteristics

Model	Outdoor Unit				Power Supply
	Hz	Voltage	Min.	Max.	MFA
38QUS018R8S*	50	220-240V	198V	254V	20
38QUS024R8S*	50	220-240V	198V	254V	20
38QUS036R8S*	50	220-240V	198V	254V	30
38QUS036R8T*	50	380-415V	342V	440V	20
38QUS048R8T*	50	380-415V	342V	440V	25
38QUS060R8T*	50	380-415V	342V	440V	25

Notes:

MFA: Max. Fuse Amps. (A)

6. Operation Limits

Mode \ Temperature	Cooling operation	Heating operation	Drying operation
Room temperature	17°C~32°C	0°C~30°C	17°C~32°C
Outdoor temperature	0°C~50°C	-15°C~24°C	0°C~50°C
	(-15°C~50°C: For the models with low temperature cooling system)		

CAUTION:

1. If the air conditioner is used beyond the above conditions, certain safety protection features may come into operation and cause the unit to operate abnormally.
2. The room relative humidity should be less than 80%. If the air conditioner operates beyond this figure, the surface of the air conditioner may attract condensation. Please set the vertical air flow louver to its maximum angle (vertically to the floor), and set HIGH fan mode.
3. The optimum performance will be achieved during this operating temperature zone.

7. Sound Levels

Outdoor Unit

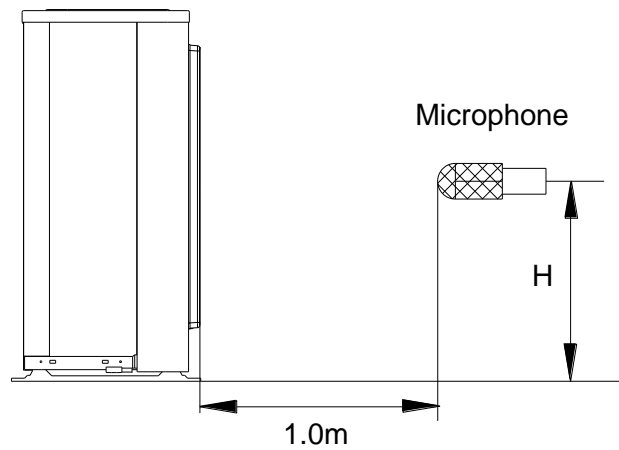

Note: $H = 0.5 \times$ height of outdoor unit

Model	Noise Power dB(A)	Noise level dB(A)
38QUS018R8S*	65	57
38QUS024R8S*	67	61
38QUS036R8S*	69	64
38QUS036R8T*	69	64
38QUS048R8T*	75	66
38QUS060R8T*	77	66

Part 4

Installation

1. Installation Procedure.....	70
2. Location selection	71
3. Indoor unit installation.....	72
4. Outdoor unit installation (Side Discharge Unit).....	82
5. Refrigerant pipe installation	83
6. Drainage pipe installation.....	87
7. Vacuum Drying and Leakage Checking	91
8. Additional refrigerant charge	92
9. Engineering of insulation	93
10. Engineering of electrical wiring	94
11. Test operation	95

1. Installation Procedure

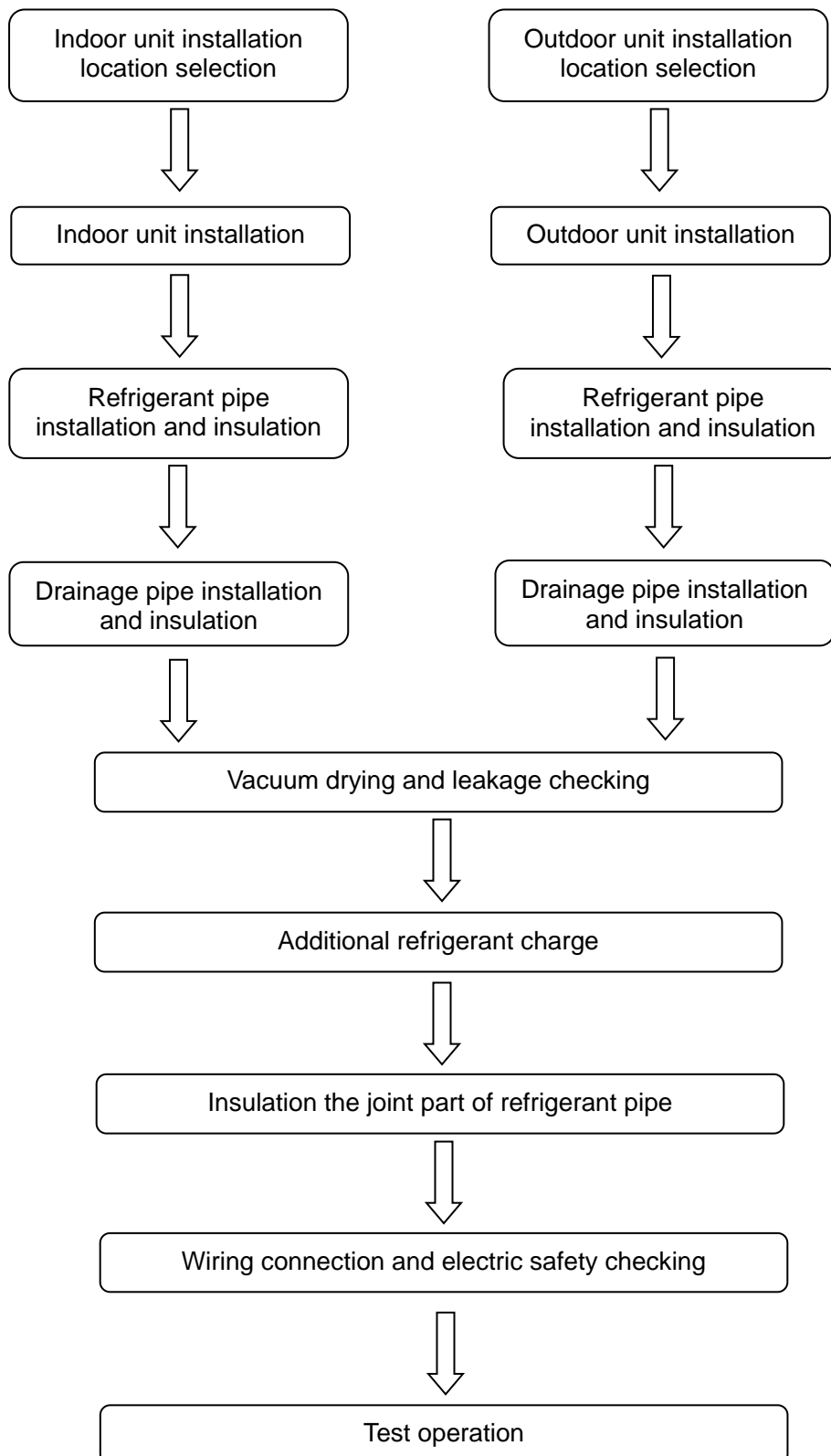

2. Location selection

2.1 Indoor unit location selection

- The place shall easily support the indoor unit's weight.
- The place can ensure the indoor unit installation and inspection.
- The place can ensure the indoor unit horizontally installed.
- The place shall allow easy water drainage.
- The place shall easily connect with the outdoor unit.
- The place where air circulation in the room should be good.
- There should not be any heat source or steam near the unit.
- There should not be any oil gas near the unit
- There should not be any corrosive gas near the unit
- There should not be any salty air near the unit
- There should not be strong electromagnetic wave near the unit
- There should not be inflammable materials or gas near the unit
- There should not be strong voltage vibration.

2.2 Outdoor unit location selection

- The place shall easily support the outdoor unit's weight.
- Locate the outdoor unit as close to indoor unit as possible
- The piping length and height drop can not exceed the allowable value.
- The place where the noise, vibration and outlet air do not disturb the neighbors.
- There is enough room for installation and maintenance.
- The air outlet and the air inlet are not impeded, and not face the strong wind.
- It is easy to install the connecting pipes and cables.
- There is no danger of fire due to leakage of inflammable gas.
- It should be a dry and well ventilation place
- The support should be flat and horizontal
- Do not install the outdoor unit in a dirty or severely polluted place, so as to avoid blockage of the heat exchanger in the outdoor unit.
- If is built over the unit to prevent direct sunlight, rain exposure, direct strong wind, snow and other scraps accumulation, make sure that heat radiation from the condenser is not restricted.

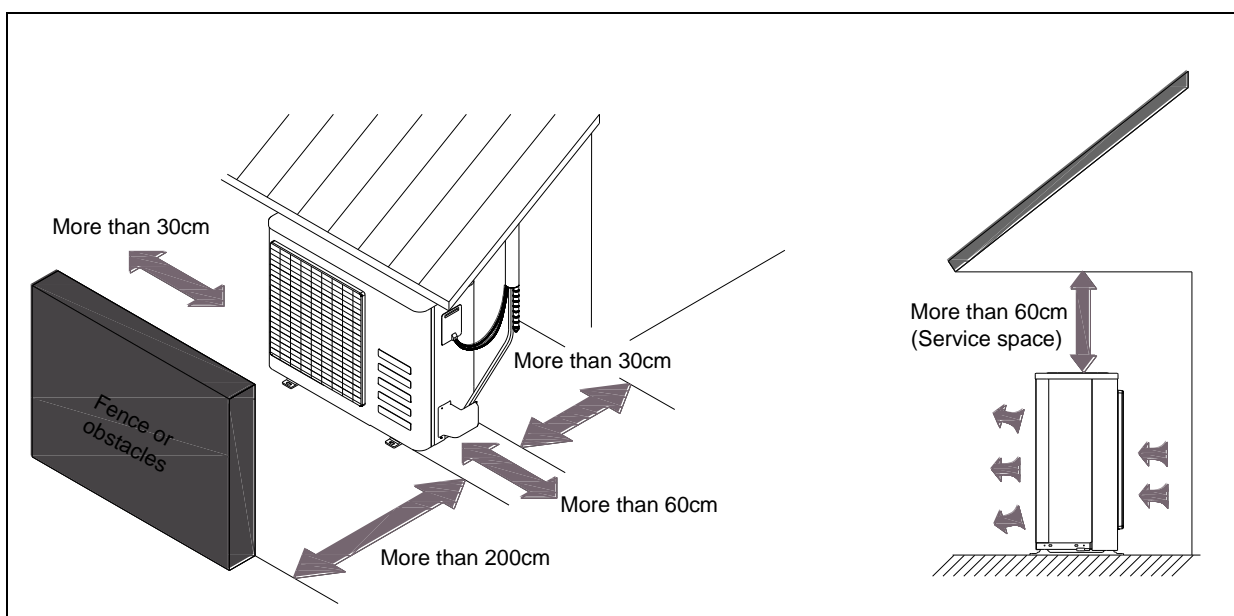

3. Indoor unit installation

3.1 Super slim cassette indoor unit installation

3.1.1 Service space for indoor unit

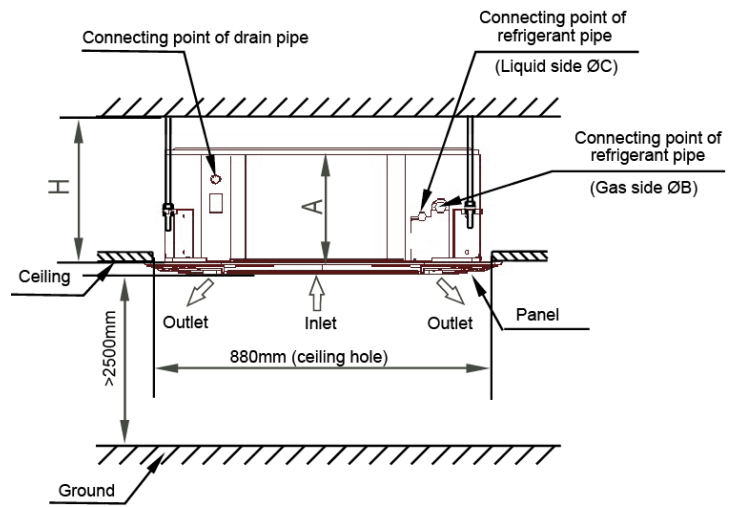
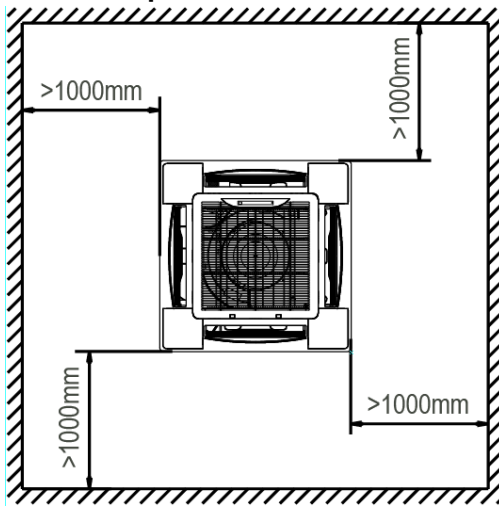

Model	A	H
18	205	>235
24~36	245	>275
48/55	287	>317

3.1.2 Bolt pitch

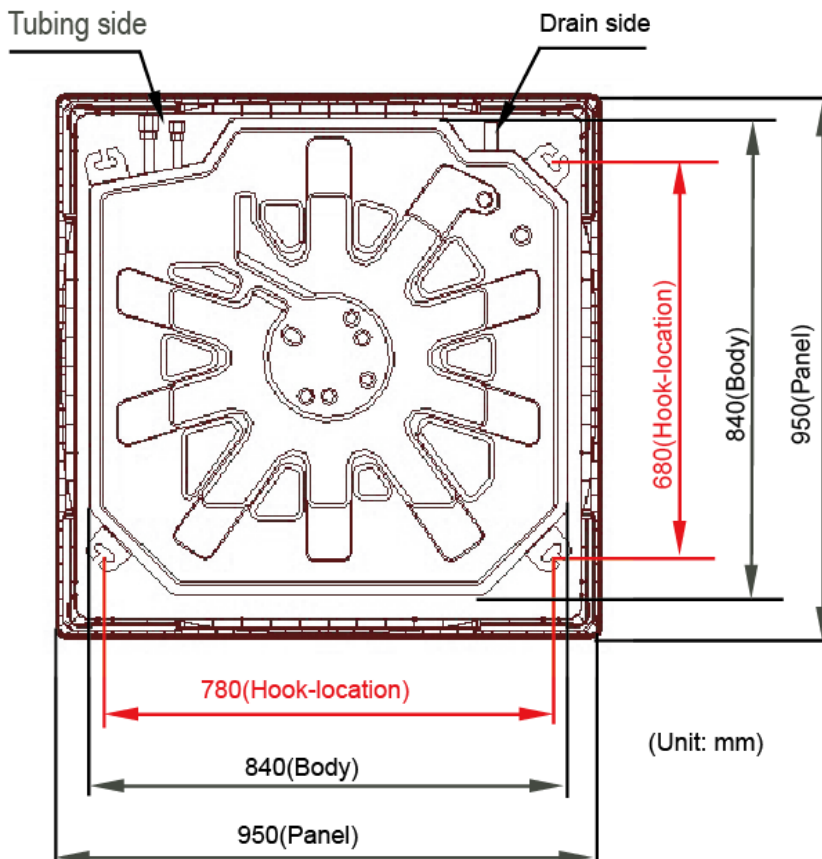

3.1.3 Install the pendant bolt

Select the position of installation hooks according to the hook holes positions showed in upper picture. Drill four holes of $\text{Ø}12\text{mm}$, 45~50mm deep at the selected positions on the ceiling. Then embed the expandable hooks (fittings).



3.1.4 Install the main body

Make the 4 suspender through the 4 hanger of the main body to suspend it. Adjust the hexangular nuts on the four installation hooks evenly, to ensure the balance of the body. Use a leveling instrument to make sure the levelness of the main body is within $\pm 1^\circ$.



Adjust the position to ensure the gaps between the body and the four sides of ceiling are even. The body's lower part should sink into the ceiling for 10~12 mm. In general, L is half of the screw length of the installation hook.

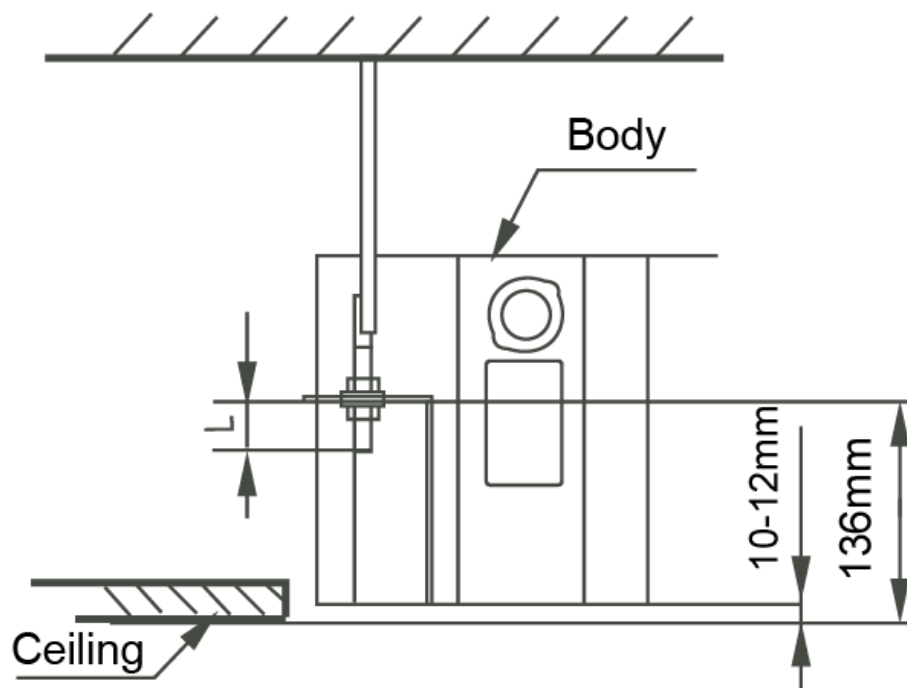

Locate the air conditioner firmly by wrenching the nuts after having adjusted the body's position well.

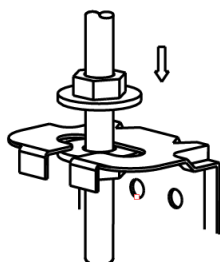

3.1.5 Install the panel

Remove the grille

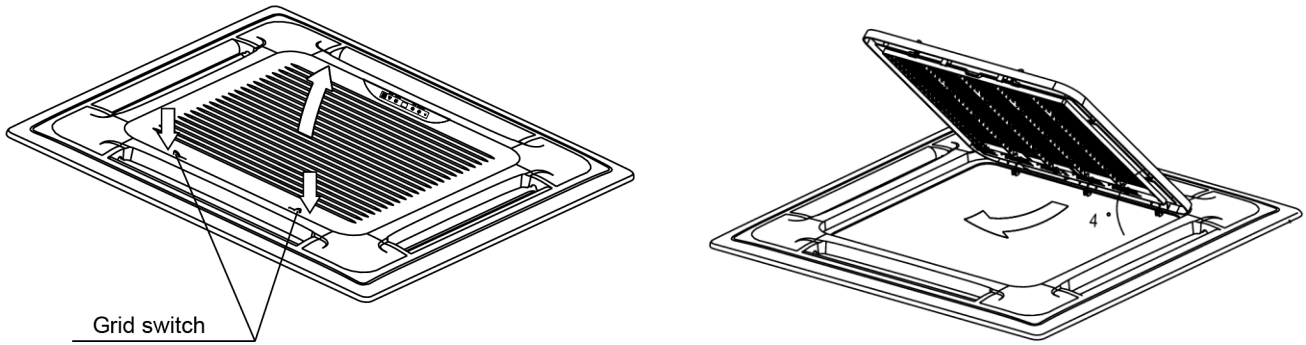

Remove the 4 corner covers.

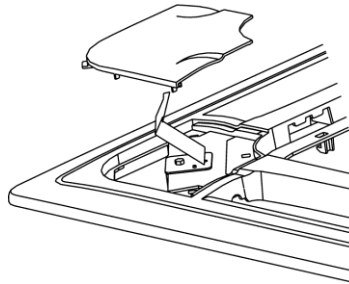

Hang the panel to the hooks on the mainbody. If the panel is with auto-lift grille, please watch the ropes lifting the grille, DO NOT make the ropes entwined or blocked.

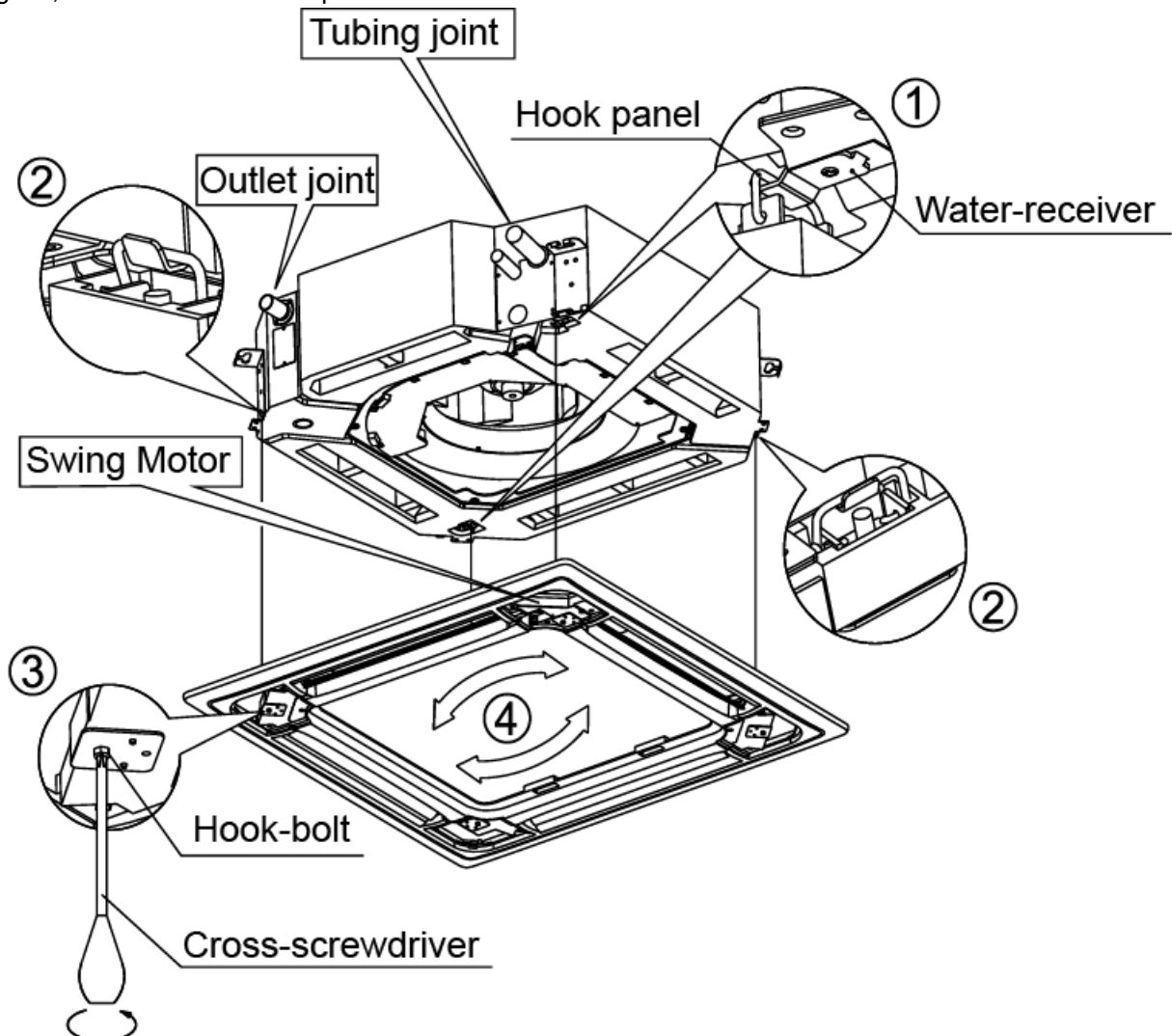

Tighten the screws under the panel hooks till the panel closely stick on the ceiling to avoid condensate water.

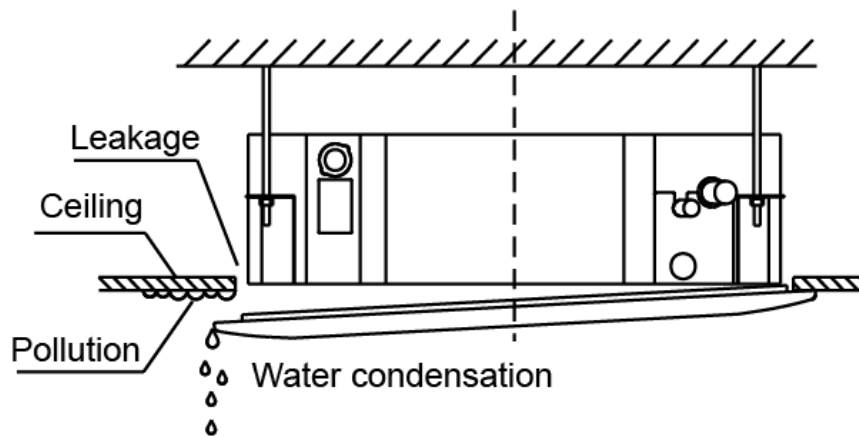
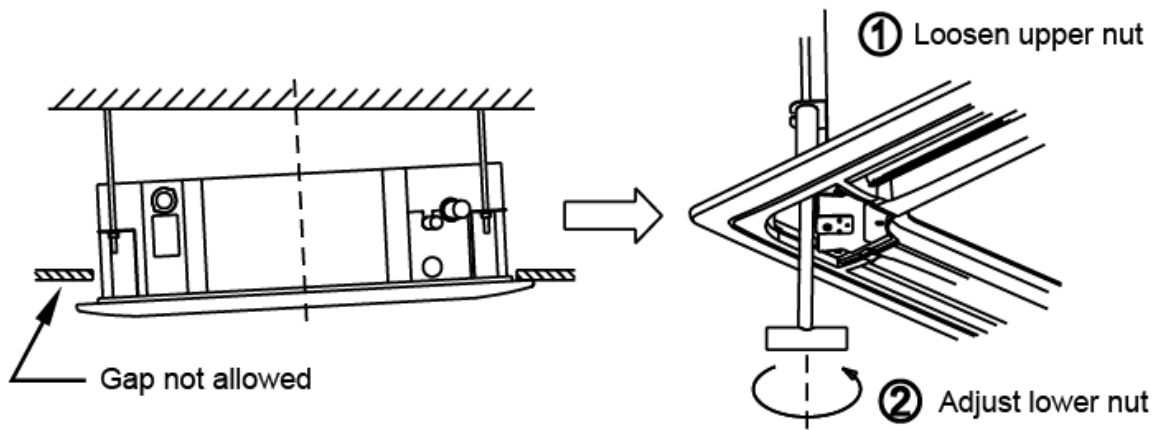

Hang the air-in grill to the panel, then connect the lead terminator of the swing motor and that of the control box with corresponding terminators on the body respectively.

Install the 4 corner covers back.

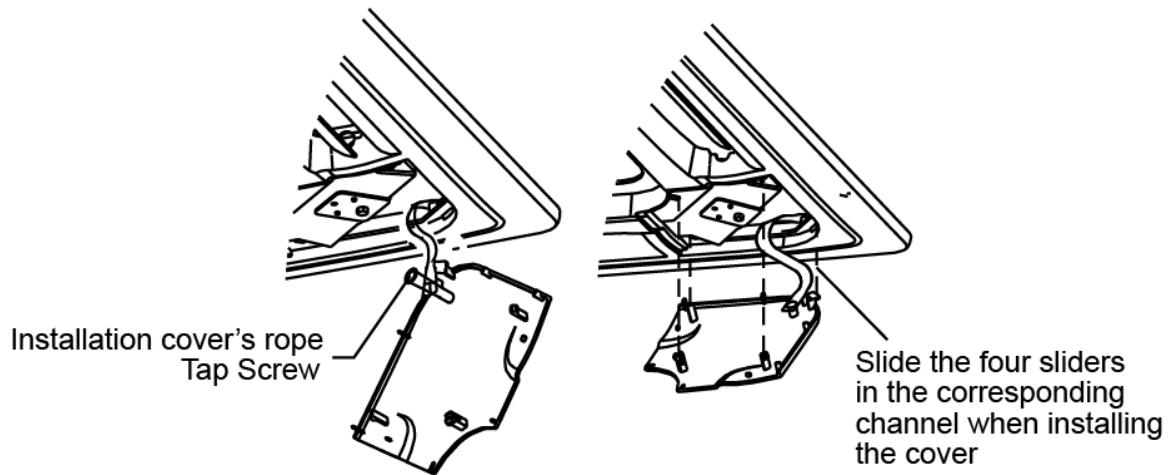

Note: The panel shall be installed after the wiring connected.

3.2 Ceiling & floor indoor unit installation

3.2.1 Service space for indoor unit

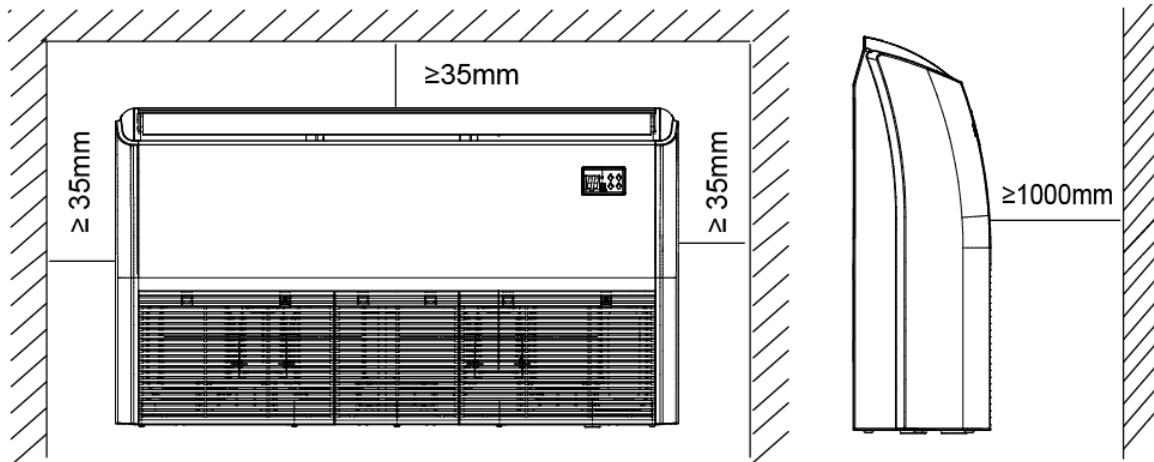

3.2.2 Bolt pitch

① Ceiling installation

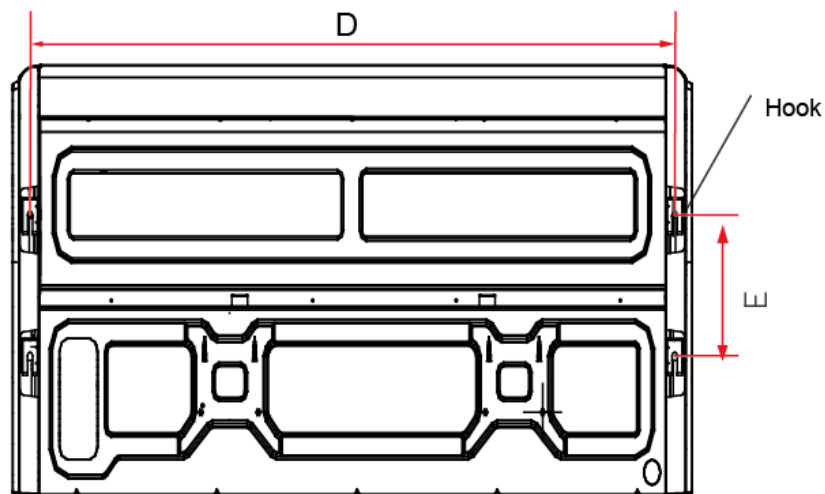

Capacity (KBtu/h)	D	E
18/24	983	220
36-60	1565	220

② Wall-mounted installation

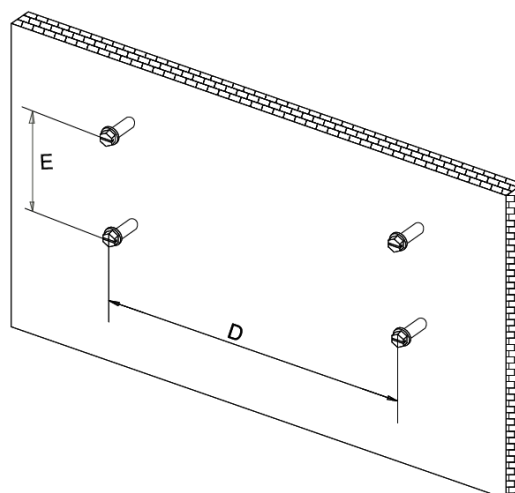

3.2.3 Install the pendant bolt

① Ceiling installation

Select the position of installation hooks according to the hook holes positions showed in upper picture.

Drill four holes of $\text{Ø}12\text{mm}$, 45~50mm deep at the selected positions on the ceiling. Then embed the expansible hooks (fittings).



② Wall-mounted installation

Install the tapping screws onto the wall.(Refer to picture below)

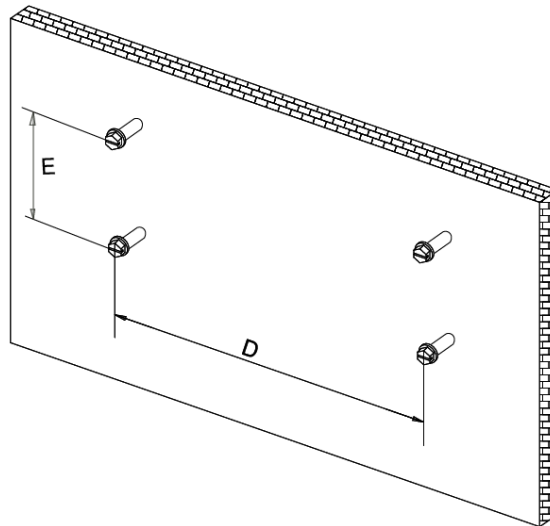

3.2.4 Install the main body

① Ceiling installation (The only installation method for the unit with drain pump)

Remove the side board and the grille.

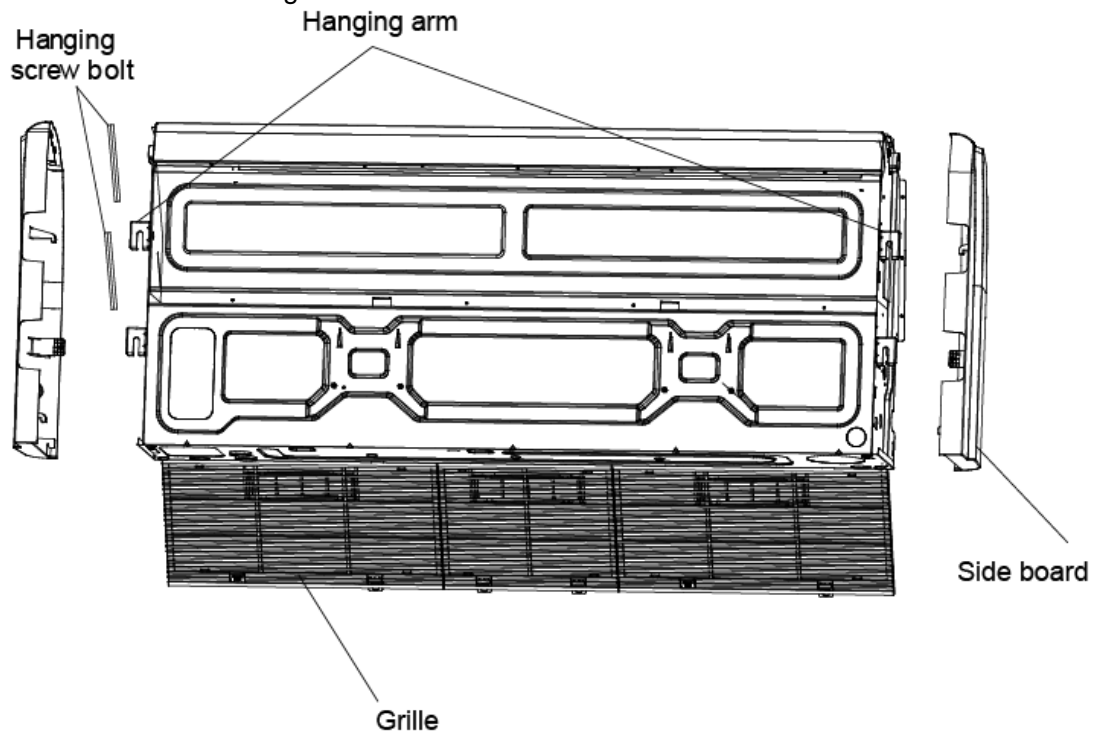

Locate the hanging arm on the hanging screw bolt. Prepare the mounting bolts on the unit.

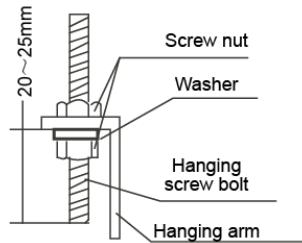

Put the side panels and grilles back.

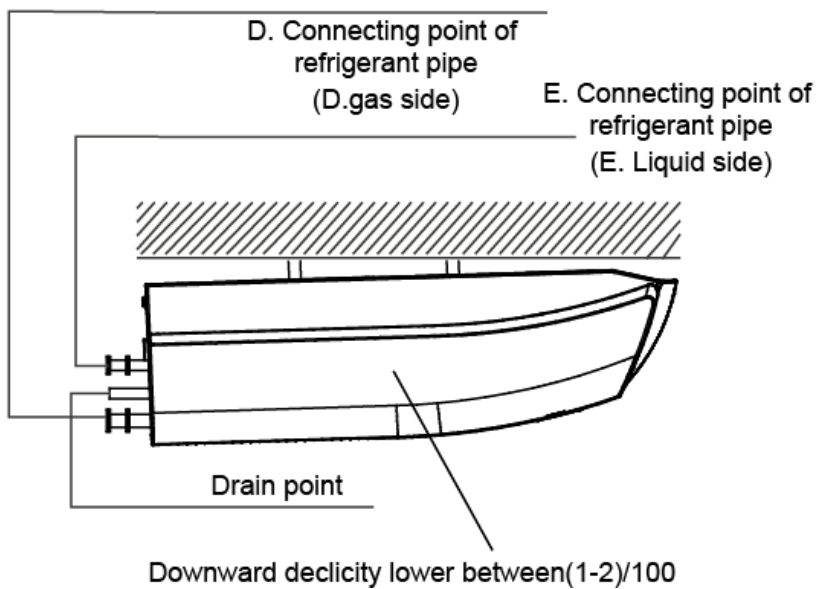
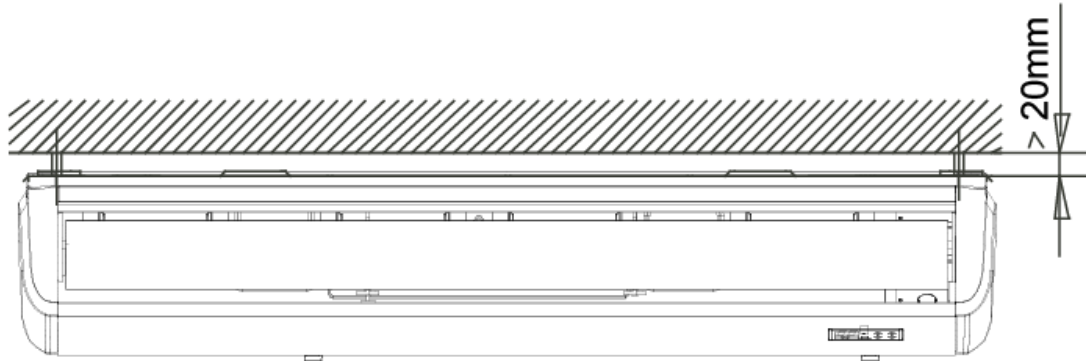

② Wall-mounted installation

Hang the indoor unit by insert the tapping screws into the hanging arms on the main unit. (The bottom of body can touch with floor or suspended, but the body must install vertically.)

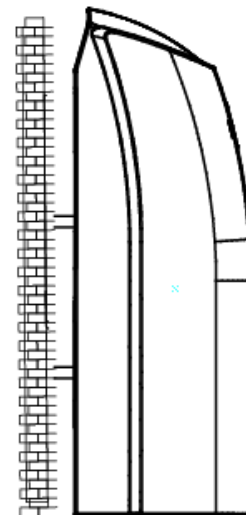
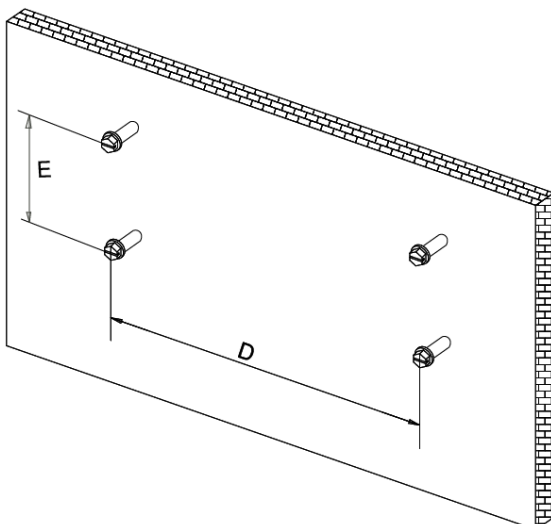

3.3 A6 duct indoor unit installation

3.3.1 Service space for indoor unit

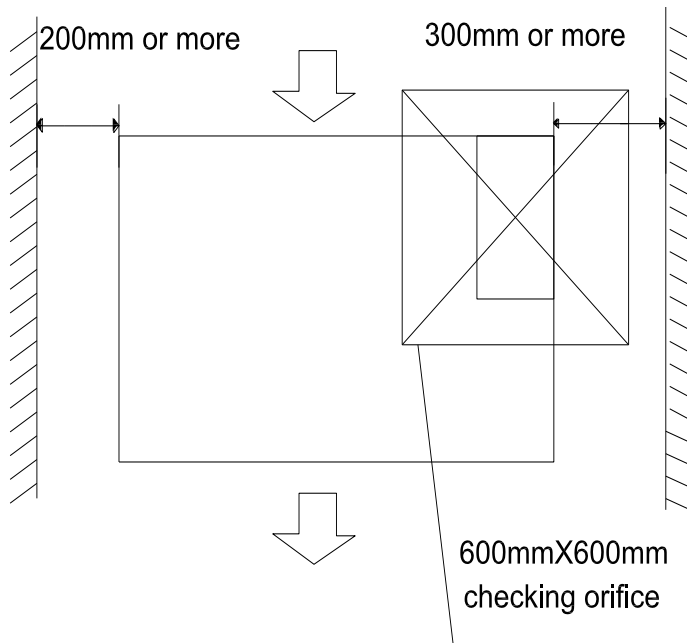

3.3.2 Bolt pitch

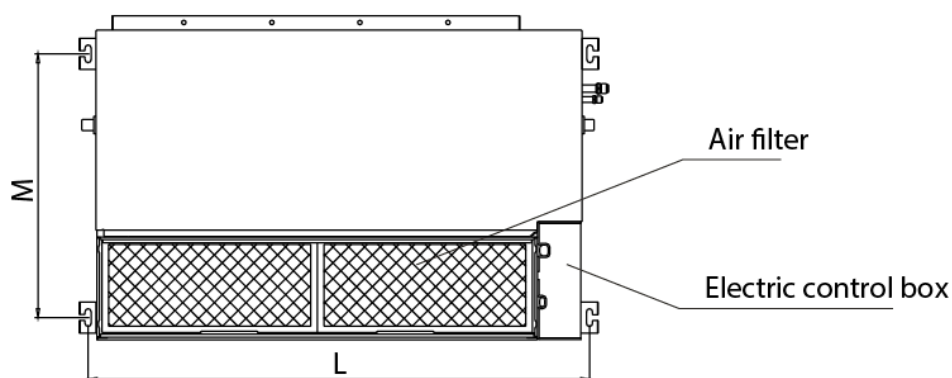

Capacity(KBtu)	Size of outline dimension mounted lug	
	L	M
18	920	508
24	1140	598
36	1400	598
48/55	1240	697

3.3.3 Hang indoor unit

1. Please refer to the upper data to locate the four positioning screw bolt hole on the ceiling. Be sure to mark the areas where ceiling hook holes will be drilled.
2. Install and fit pipes and wires after you have finished installing the main body. When choosing where to start, determine the direction of the pipes to be drawn out. Especially in cases where there is a ceiling involved, align the refrigerant pipes, drain pipes, and indoor and outdoor lines with their connection points before mounting the unit.
3. Install hanging screw bolts.
 - Cut off the roof beam.
 - Strengthen the place that has been cut off, and consolidate the roof beam.

4. After you select an installation location, align the refrigerant pipes, drain pipes, as well as indoor and outdoor wires with their connection points before mounting the unit.
5. Drill 4 holes 10cm (4") deep at the ceiling hook positions in the internal ceiling. Be sure to hold the drill at a 90° angle to the ceiling.
6. Secure the bolt using the washers and nuts provided.
7. Install the four suspension bolts.
8. Mount the indoor unit with at least two people to lift and secure it. Insert suspension bolts into the unit's hanging holes. Fasten them using the washers and nuts provided.

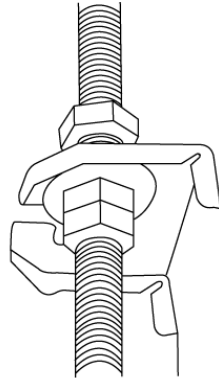

9. Mount the indoor unit onto the hanging screw bolts with a block. Position the indoor unit flat using a level indicator to prevent leaks.

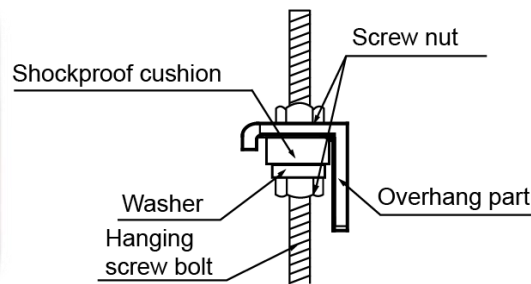

Note: Confirm the minimum drain tilt is 1/100 or more.

3.3.4 Duct and accessories installation

1. Install the filter (optional) according to the size of the air inlet.
2. Install the canvas tie-in between the body and the duct.
3. Air inlet and air outlet duct should be apart far enough to avoid air passage short-circuit.
4. Connect the duct according to the following diagram.

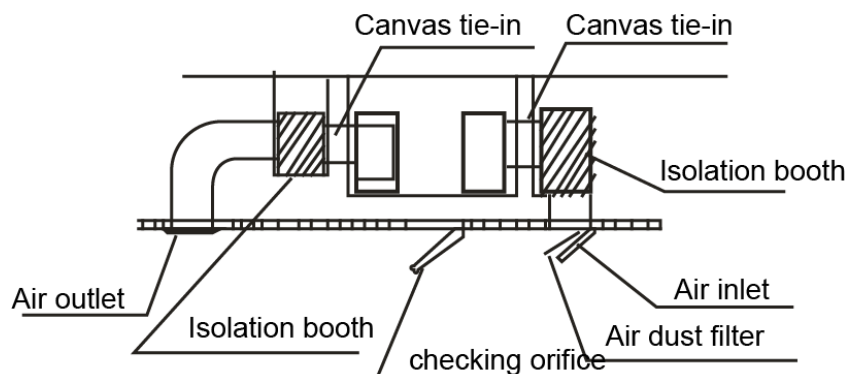

5. Please refer to the following static pressure to install..

Model(KBtu/h)	Static Pressure(Pa)
18	0-100
24~55	0-160

Change the fan motor static pressure corresponding to external duct static pressure.

NOTE: 1. Do not put the connecting duct weight on the indoor unit.

2. When connecting duct, use inflammable canvas tie-in to prevent vibrating.

3. Insulation foam must be wrapped outside the duct to avoid condensate. An internal duct underlayer can be added to reduce noise, if the end-user requires.

3.8.5 Adjust the air inlet direction (From rear side to under-side.)

① Take off ventilation panel and flange, cut off the staples at side rail

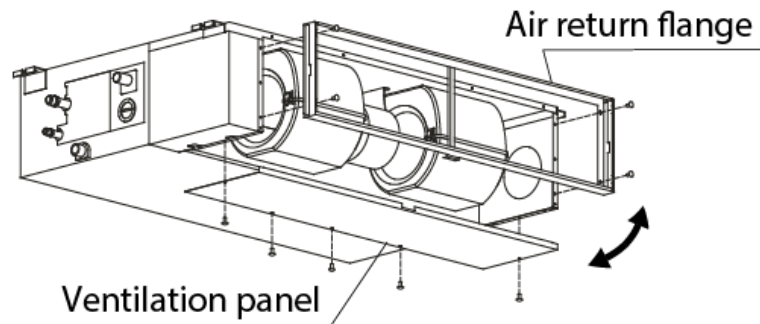

② Change the mounting positions of ventilation panel and air return flange .

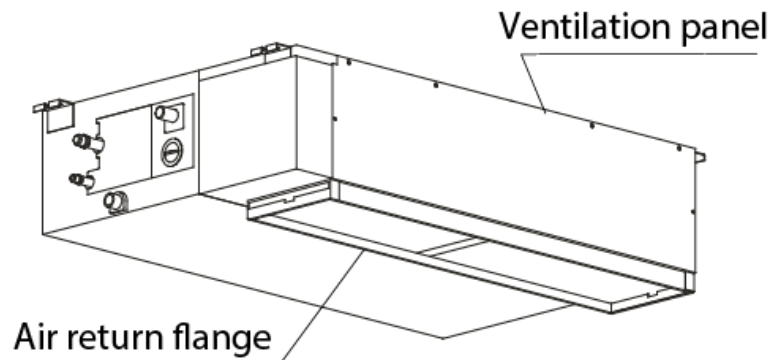

③ When installing the filter mesh, fit it into the flange as illustrated in the following figure.

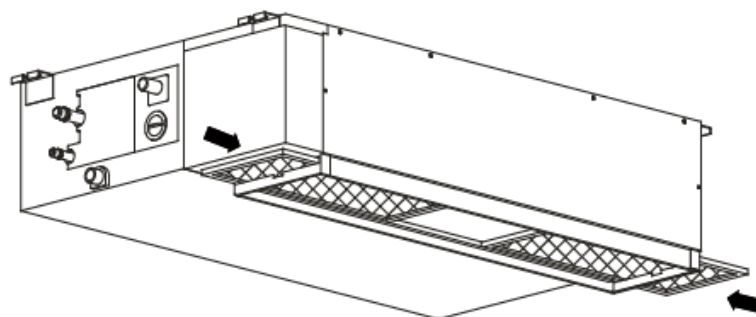

NOTE: All the figures in this manual are for explanation purpose only. They may be slightly different from the air conditioner you purchased.

4. Outdoor unit installation (Side Discharge Unit)

4.1 Service space for outdoor unit

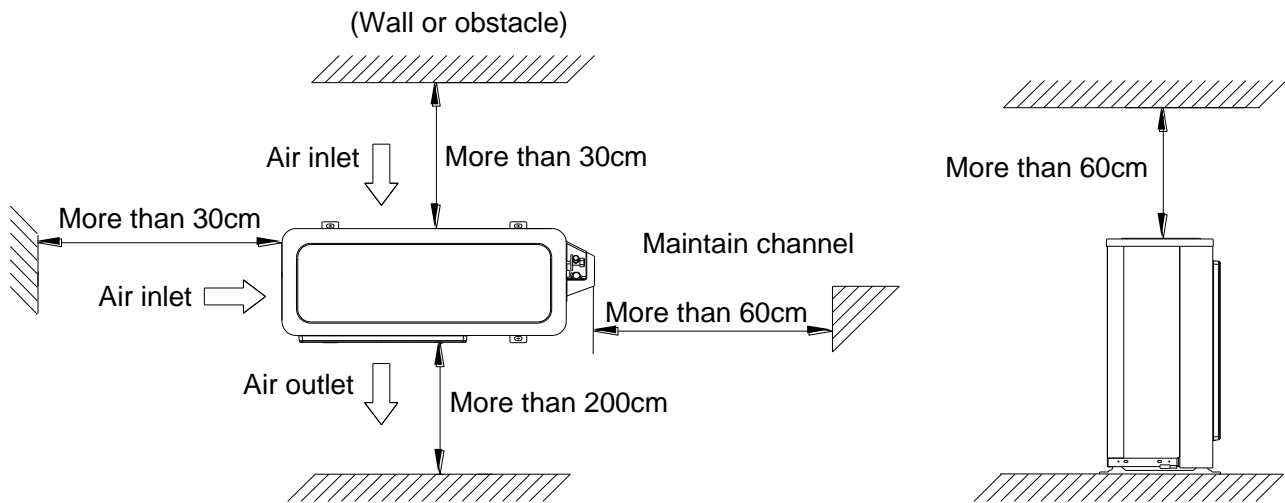

4.2 Bolt pitch

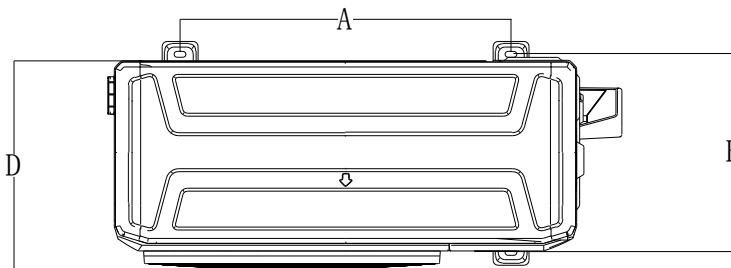

Model	A	B	D
18	514	340	333
24	540	350	363
36	673	403	410
48/55	634	404	415

4.3 Install the Unit

Since the gravity center of the unit is not at its physical center, so please be careful when lifting it with a sling. Never hold the inlet of the outdoor unit to prevent it from deforming.

Do not touch the fan with hands or other objects.

Do not lean it more than 45°, and do not lay it sidelong.

Make concrete foundation according to the specifications of the outdoor units.

Fasten the feet of this unit with bolts firmly to prevent it from collapsing in case of earthquake or strong wind.

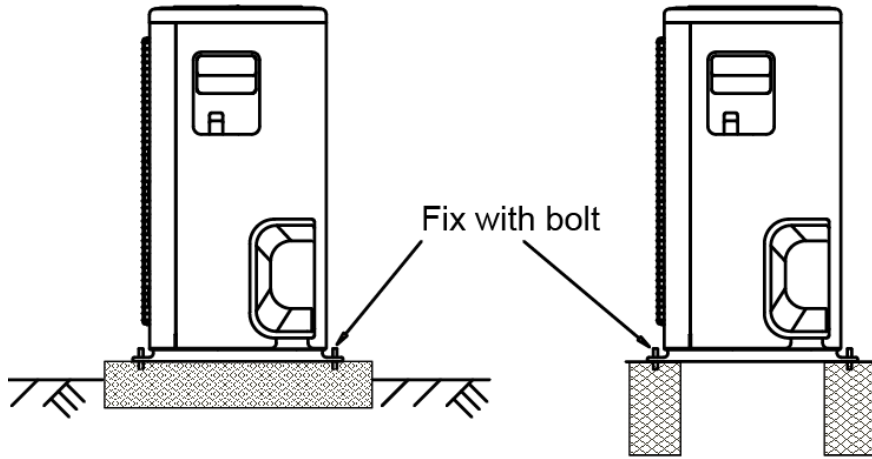

5. Refrigerant pipe installation

5.1 Maximum pipe length and height drop

Considering the allowable pipe length and height drop to decide the installation position. Make sure the distance and height drop between indoor and outdoor unit not exceeded the data in the following table.

Model	Max. Length	Max. Elevation
12,000Btu/h	25m	10m
16,000~18,000Btu/h	30m	20m
24,000Btu/h~30,000Btu/h	50m	25m
36,000Btu/h ~60,000Btu/h	65m	30m

5.2 The procedure of connecting pipes

5.2.1 Choose the pipe size according to the specification table.

5.2.2 Confirm the cross way of the pipes.

5.2.3 Measure the necessary pipe length.

5.2.4 Cut the selected pipe with pipe cutter

- Make the section flat and smooth.

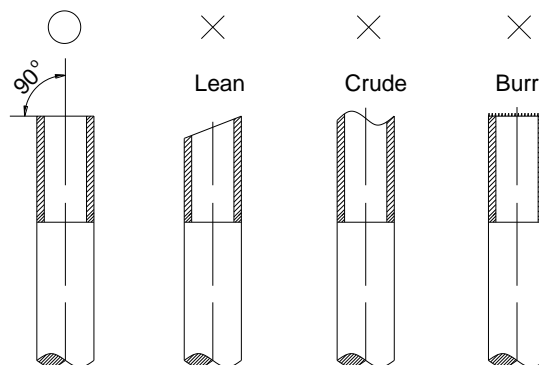

5.2.5 Insulate the copper pipe

- Before test operation, the joint parts should not be heat insulated.

5.2.6 Flare the pipe

- Insert a flare nut into the pipe before flaring the pipe
- According to the following table to flare the pipe

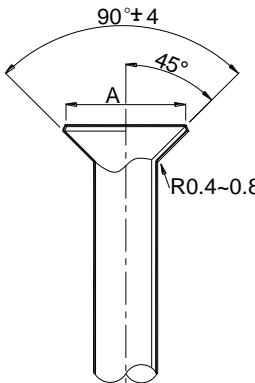
Pipe diameter	Flare dimension A (mm)		Flare shape
	Min	Max	
1/4" (6.35)	8.3	8.7	
3/8" (9.52)	12.0	12.4	
1/2" (12.7)	15.4	15.8	
5/8" (15.9)	18.6	19.1	
3/4" (19)	22.9	23.3	

- After flared the pipe, the opening part must be seal by end cover or adhesive tape to avoid duct or exogenous impurity come into the pipe.

5.2.7 Drill holes if the pipes need to pass the wall.

5.2.8 According to the field condition to bend the pipes so that it can pass the wall smoothly.

5.2.9 Bind and wrap the wire together with the insulated pipe if necessary.

5.2.10 Set the wall conduit

5.2.11 Set the supporter for the pipe.

5.2.12 Locate the pipe and fix it by supporter

- For horizontal refrigerant pipe, the distance between supporters should not be exceed 1m.
- For vertical refrigerant pipe, the distance between supporters should not be exceed 1.5m.

5.2.13 Connect the pipe to indoor unit and outdoor unit by using two spanners.

- Be sure to use two spanners and proper torque to fasten the nut, too large torque will damage the bellmouthing, and too small torque may cause leakage. Refer the following table for different pipe connection.

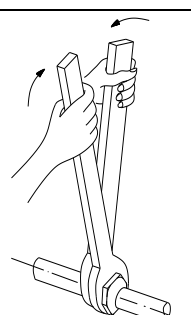
Pipe Diameter	Torque		Sketch map
	(kgf.cm)	(N.cm)	
1/4" (6.35)	144~176	1420~1720	
3/8" (9.52)	333~407	3270~3990	
1/2" (12.7)	504~616	4950~6030	
5/8" (15.9)	630~770	6180~7540	
3/4" (19)	990~1210	9270~11860	

5.3 For Units with Twins Function

5.3.1 Length and drop height permitted of the refrigerant piping

Note: Reduced length of the branching tube is the 0.5m of the equivalent length of the pipe.

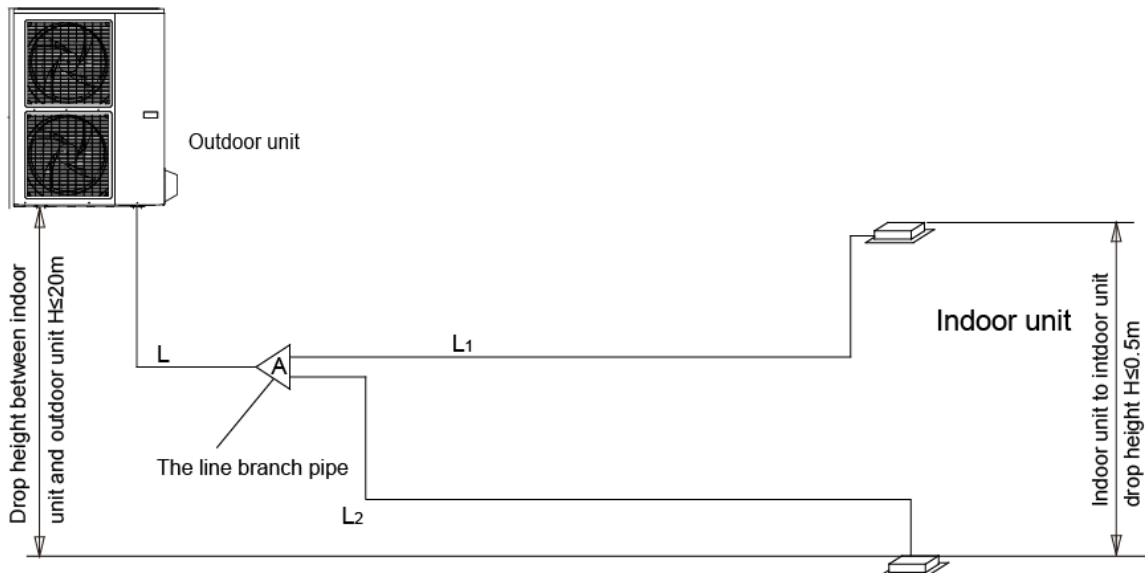

Note: All used branch pipe must be produced by Midea, otherwise it causes malfunction. The indoor units should be installed equivalently at the both side of the U type branch pipe.

		Permitted Value		Piping
Pipe Length	Total pipe length (Actual)	18K+18K	30m	L+L1+L2
		24K+24K	50m	
		30K+30K	50m	
	Max. branch pipe length		15m	L1, L2
	Max. branch pipe length difference		10m	L1-L2
Drop Height	Max. height difference between indoor unit and outdoor unit		20m	H1
	Max. height difference between indoor units		0.5m	H2

5.3.2 Size of joint pipes for indoor unit (R410a)

Capacity of indoor unit (A)	Size of main pipe(mm)		
	Gas side	Liquid side	Available branching pipe
18K	Φ12.7	Φ6.35	CE-FQZHN-01C
24K	Φ15.9	Φ9.5	CE-FQZHN-01C
30K	Φ15.9	Φ9.5	CE-FQZHN-01C

5.3.3 Size of joint pipes for outdoor unit (R410a)

Model	the size of main pipe(mm)		
	Gas side	Liquid side	The 1st branching pipe
36K	Φ15.9	Φ9.5	CE-FQZHN-01C
48K	Φ15.9	Φ9.5	CE-FQZHN-01C
60K	Φ15.9	Φ9.5	CE-FQZHN-01C

5.3.4 The branching pipe must be installed horizontally, error angle of it should not large than 10°. Otherwise, malfunction will be caused.

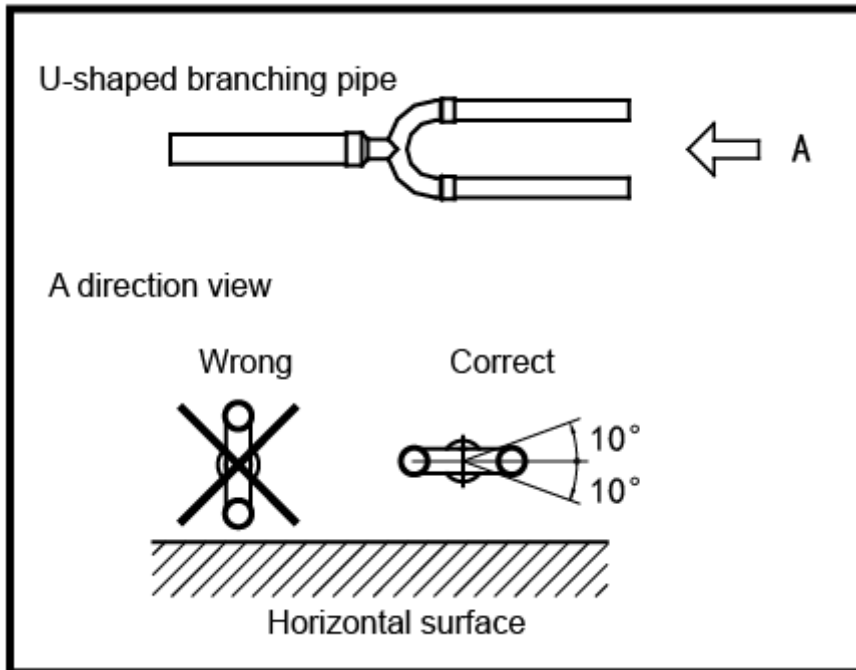

6. Drainage pipe installation

Install the drainage pipe as shown below and take measures against condensation. Improperly installation could lead to leakage and eventually wet furniture and belongings.

6.1 Installation principle

- Ensure at least 1/100 slope of the drainage pipe
- Adopt suitable pipe diameter
- Adopt nearby condensate water discharge

6.2 Key points of drainage water pipe installation

6.2.1 Considering the pipeline route and elevation

- Before installing condensate water pipeline, determine its route and elevation to avoid intersection with other pipelines and ensure slope is straight.

6.2.2 Drainage pipe selection

- The drainage pipe diameter shall not small than the drain hose of indoor unit
- According to the water flowrate and drainage pipe slope to choose the suitable pipe, the water flowrate is decided by the capacity of indoor unit.

Relationship between water flowrate and capacity of indoor unit

Capacity (x1000Btu)	Water flowrate (l/h)
12	2.4
18	4
24	6
30	7
36	8
42	10
48	12
60	14

According to the above table to calculate the total water flowrate for the confluence pipe selection.

For horizontal drainage pipe (The following table is for reference)

PVC pipe	Reference value of inner diameter of pipe (mm)	Allowable maximum water flowrate (l/h)		Remark
		Slope 1/50	Slope 1/100	
PVC25	20	39	27	For branch pipe
PVC32	25	70	50	
PVC40	31	125	88	
PVC50	40	247	175	Could be used for confluence pipe
PVC63	51	473	334	

Attention: Adopt PVC40 or bigger pipe to be the main pipe.

For Vertical drainage pipe (The following table is for reference)

PVC pipe	Reference value of inner diameter of pipe (mm)	Allowable maximum water flowrate (l/h)	Remark
PVC25	20	220	For branch pipe
PVC32	25	410	
PVC40	31	730	
PVC50	40	1440	Could be used for confluence pipe
PVC63	51	2760	
PVC75	67	5710	
PVC90	77	8280	

Attention: Adopt PVC40 or bigger pipe to be the main pipe.

6.2.3 Individual design of drainage pipe system

- The drainage pipe of air conditioner shall be installed separately with other sewage pipe, rainwater pipe and drainage pipe in building.
- The drainage pipe of the indoor unit with water pump should be apart from the one without water pump.

6.2.4 Supporter gap of drainage pipe

- In general, the supporter gap of the drainage pipe horizontal pipe and vertical pipe is respectively 1m~1.5m and 1.5m~2.0m.
- Each vertical pipe shall be equipped with not less than two hangers.
- Overlarge hanger gap for horizontal pipe shall create bending, thus leading to air block.

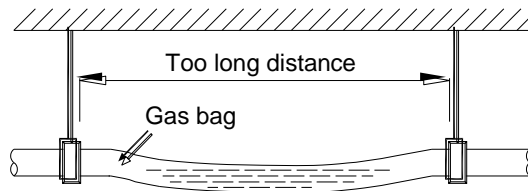

6.2.5 The horizontal pipe layout should avoid converse flow or bad flow

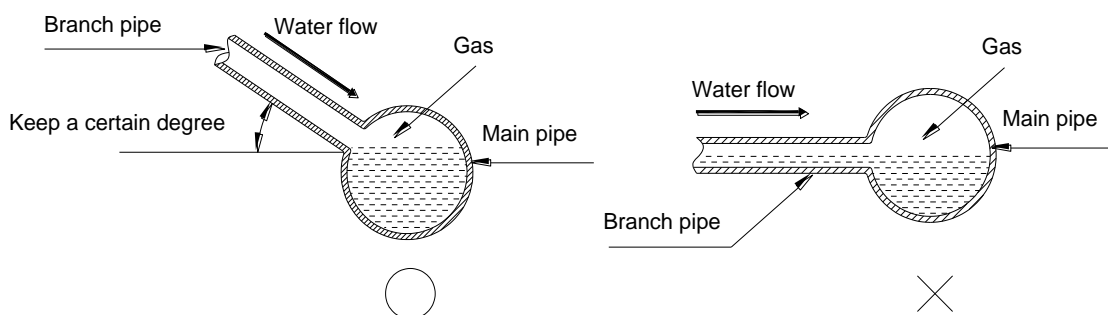
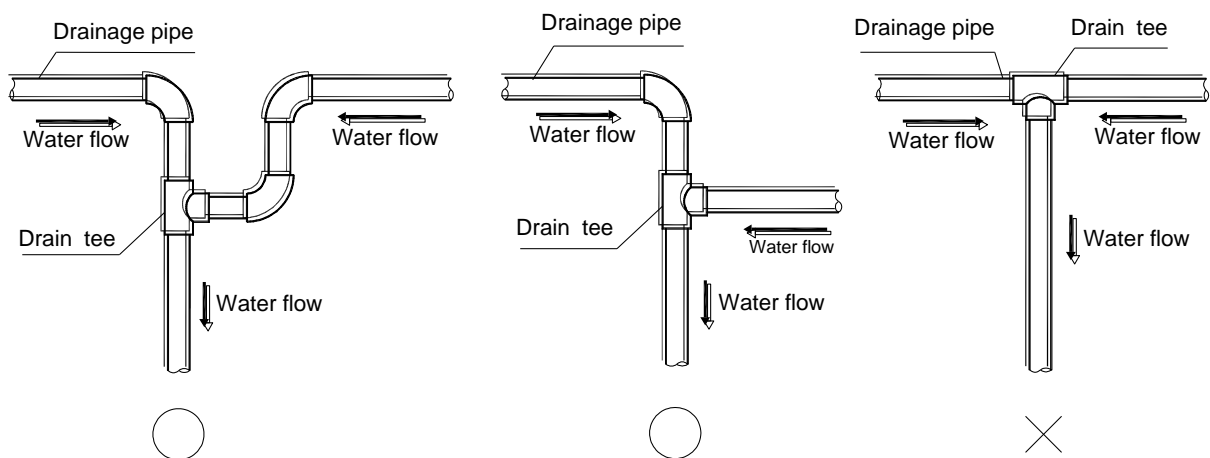

- The correct installation will not cause converse water flow and the slope of the branch pipes can be adjusted freely
- The false installation will cause converse water flow and the slope of the branch pipe can not be adjusted.

6.2.6 Water storage pipe setting

- If the indoor unit has high extra static pressure and without water pump to elevate the condensate water, such as high extra static pressure duct unit, the water storage pipe should be set to avoid converse flow or blow water phenomena.

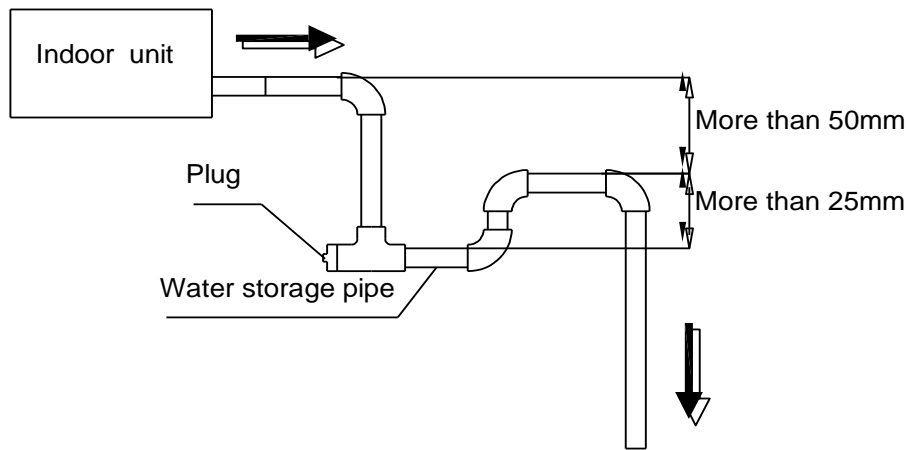

6.2.7 Lifting pipe setting of indoor unit with water pump

- The length of lifting pipe should not exceed the pump head of indoor unit water pump.
Pump head of big four way cassette: 750mm
Pump head of compact four way cassette: 500mm
- The drainage pipe should be set down inclined after the lifting pipe immediately to avoid wrong operation of water level switch.
- Refer the following picture for installation reference.

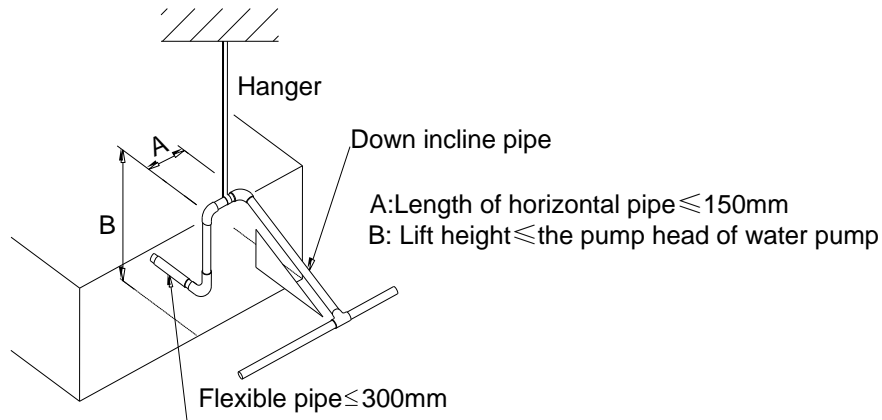

6.2.8 Blowhole setting

- For the concentrated drainage pipe system, there should design a blowhole at the highest point of main pipe to ensure the condensate water discharge smoothly.
- The air outlet shall face down to prevent dirt entering pipe.
- Each indoor unit of the system should be installed it.
- The installation should be considering the convenience for future cleaning.

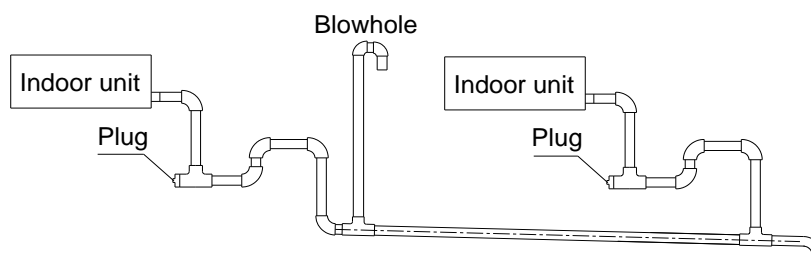

6.2.9 The end of drainage pipe shall not contact with ground directly.

6.3 Drainage test

6.3.1 Water leakage test

After finishing the construction of drainage pipe system, fill the pipe with water and keep it for 24 hours to check whether there is leakage at joint section.

6.3.2 Water discharge test

1. Natural drainage mode(the indoor unit with outdoor drainage pump)

Infuse above 600ml water through water test hole slowly into the water collector, observe whether the water can discharge through the transparent hard pipe at drainage outlet.
2. Pump drainage mode
 - 2.1 Disconnect the plug of water level switch, remove the cover of water test hole and slowly infuse about 2000ml water through the water test hole, be sure that the water will not touch the motor of drainage pump.

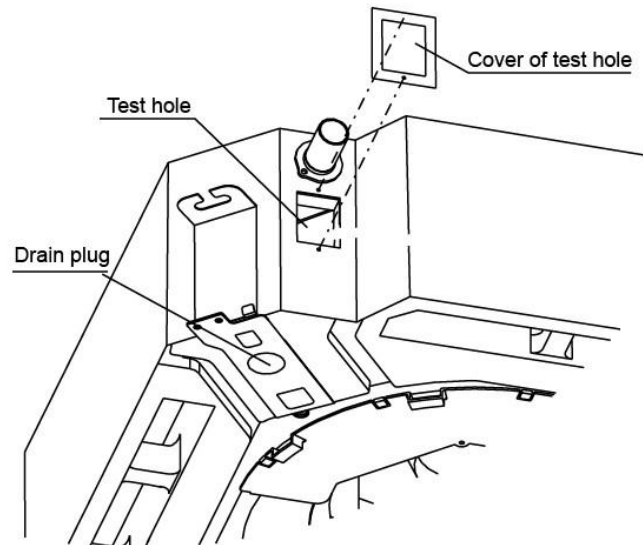

- 2.2 Power on and let the air conditioner operate for cooling. Check operation status of drainage pump, and then connect the plug of water level switch, check the operation sound of water pump and observe whether the water can discharge through the transparent hard pipe at drainage outlet. (In light of the length of drainage pipe, water shall be discharged about 1 minute delayed)
- 2.3 Stop the operation of air conditioner, power off the power supply and put the cover of water test hole back to the original place.
 - a. After stopped the air conditioner 3 minutes, check whether there is anything abnormal. If drainage pipes have not been distributed properly, over back-flow water shall cause the flashing of alarm indicator at remote-controlled receiving board and even water shall run over the water collector.
 - b. Continuously infusing water until water level alarmed, check whether the drainage pump could discharge water at once. If water level does not decline under warning water level 3 minutes later, it shall cause shutdown of unit. When this situation happens, the normal startup only can be recovered by turning down power supply and eliminating accumulated water.

Note: Drain plug at the main water-containing plate is used for eliminating accumulated water in water-containing plate when maintaining air conditioner fault. During normal operation, the plug shall be filled in to prevent leakage.

6.4 Insulation work of drainage pipe

Refer the introduction to the insulation engineering parts.

7. Vacuum Drying and Leakage Checking

4.1 Purpose of vacuum drying

- Eliminating moisture in system to prevent the phenomena of ice-blockage and copper oxidation. Ice-blockage shall cause abnormal operation of system, while copper oxide shall damage compressor.
- Eliminating the non-condensable gas (air) in system to prevent the components oxidizing, pressure fluctuation and bad heat exchange during the operation of system.

4.2 Selection of vacuum pump

- The ultimate vacuum degree of vacuum pump shall be -756mmHg or above.
- Precision of vacuum pump shall reach 0.02mmHg or above.

4.3 Operation procedure for vacuum drying

Due to different construction environment, two kinds of vacuum drying ways could be chosen, namely ordinary vacuum drying and special vacuum drying.

7.3.1 Ordinary vacuum drying

1. When conduct first vacuum drying, connect pressure gauge to the infusing mouth of gas pipe and liquid pipe, and keep vacuum pump running for 1 hour (vacuum degree of vacuum pump shall be reached -755mmHg).
2. If the vacuum degree of vacuum pump could not reach -755mmHg after 1 hour of drying, it indicates that there is moisture or leakage in pipeline system and need to go on with drying for half an hour.
3. If the vacuum degree of vacuum pump still could not reach -755mmHg after 1.5 hours of drying, check whether there is leakage source.
4. Leakage test: After the vacuum degree reaches -755mmHg, stop vacuum drying and keep the pressure for 1 hour. If the indicator of vacuum gauge does not go up, it is qualified. If going up, it indicates that there is moisture or leak source.

7.3.2 Special vacuum drying

The special vacuum drying method shall be adopted when:

1. Finding moisture during flushing refrigerant pipe.
2. Conducting construction on rainy day, because rain water might penetrated into pipeline.
3. Construction period is long, and rain water might penetrated into pipeline.
4. Rain water might penetrate into pipeline during construction.

Procedures of special vacuum drying are as follows:

1. Vacuum drying for 1 hour.
2. Vacuum damage, filling nitrogen to reach 0.5Kgf/cm² .
Because nitrogen is dry gas, vacuum damage could achieve the effect of vacuum drying, but this method could not achieve drying thoroughly when there is too much moisture. Therefore, special attention shall be drawn to prevent the entering of water and the formation of condensate water.
3. Vacuum drying again for half an hour.
If the pressure reached -755mmHg, start to pressure leakage test. If it cannot reached the value, repeat vacuum damage and vacuum drying again for 1 hour.
4. Leakage test: After the vacuum degree reaches -755mmHg, stop vacuum drying and keep the pressure for 1 hour. If the indicator of vacuum gauge does not go up, it is qualified. If going up, it indicates that there is moisture or leak source.

8. Additional refrigerant charge

- After the vacuum drying process is carried out, the additional refrigerant charge process need to be performed.
- The outdoor unit is factory charged with refrigerant. The additional refrigerant charge volume is decided by the diameter and length of the liquid pipe between indoor and outdoor unit. Refer the following formula to calculate the charge volume.

Diameter of liquid pipe (mm)	Φ6.35	Φ9.52
Formula	$V=15g/m \times (L-5)$	$V=30g/m \times (L-5)$

V: Additional refrigerant charge volume (g).

L : The length of the liquid pipe (m).

Note:

- Refrigerant may only be charged after performed the vacuum drying process.
- Always use gloves and glasses to protect your hands and eyes during the charge work.
- Use electronic scale or fluid infusion apparatus to weight refrigerant to be recharged. Be sure to avoid extra refrigerant charged, it may cause liquid hammer of the compressor or protections.
- Use supplementing flexible pipe to connect refrigerant cylinder, pressure gauge and outdoor unit. And The refrigerant should be charged in liquid state. Before recharging, The air in the flexible pipe and manifold gauge should be exhausted.
- After finished refrigerant recharge process, check whether there is refrigerant leakage at the connection joint part.(Using gas leakage detector or soap water to detect).

9. Engineering of insulation

9.1 Insulation of refrigerant pipe

9.1.1 Operational procedure of refrigerant pipe insulation

Cut the suitable pipe → insulation (except joint section) → flare the pipe → piping layout and connection → vacuum drying → insulate the joint parts

9.1.2 Purpose of refrigerant pipe insulation

- During operation, temperature of gas pipe and liquid pipe shall be over-heating or over-cooling extremely. Therefore, it is necessary to carry out insulation; otherwise it shall debase the performance of unit and burn compressor.
- Gas pipe temperature is very low during cooling. If insulation is not enough, it shall form dew and cause leakage.
- Temperature of gas pipe is very high (generally 50-100°C) during heating. Insulation work must be carried out to prevent hurt by carelessness touching.

9.1.3 Insulation material selection for refrigerant pipe

- The burning performance should over 120°C
- According to the local law to choose insulation materials
- The thickness of insulation layer shall be above 10mm. If in hot or wet environment place, the layer of insulation should be thicker accordingly.

9.1.4 Installation highlights of insulation construction

- Gas pipe and liquid pipe shall be insulated separately, if the gas pipe and liquid pipe were insulated together; it will decrease the performance of air conditioner.

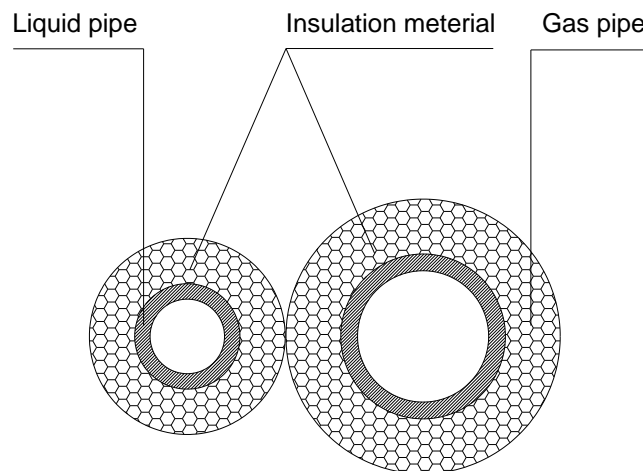

- The insulation material at the joint pipe shall be 5~10cm longer than the gap of the insulation material.
- The insulation material at the joint pipe shall be inserted into the gap of the insulation material.
- The insulation material at the joint pipe shall be banded to the gap pipe and liquid pipe tightly.
- The linking part should be use glue to paste together
- Be sure not bind the insulation material over-tight, it may extrude out the air in the material to cause bad insulation and cause easy aging of the material.

9.2 Insulation of drainage pipe

9.2.1 Operational procedure of refrigerant pipe insulation

Select the suitable pipe → insulation (except joint section) → piping layout and connection → drainage test → insulate the joint parts

9.2.2 Purpose of drainage pipe insulation

The temperature of condensate drainage water is very low. If insulation is not enough, it shall form dew and cause leakage to damage the house decoration.

9.2.3 Insulation material selection for drainage pipe

- The insulation material should be flame retardant material, the flame retardancy of the material should be selected according to the local law.
- Thickness of insulation layer is usually above 10mm.
- Use specific glue to paste the seam of insulation material, and then bind with adhesive tape. The width of tape shall not be less than 5cm. Make sure it is firm and avoid dew.

9.2.4 Installation and highlights of insulation construction

- The single pipe should be insulated before connecting to another pipe, the joint part should be insulated after the drainage test.
- There should be no insulation gap between the insulation material.

10. Engineering of electrical wiring

10.1 Highlights of electrical wiring installation

- All field wiring construction should be finished by qualified electrician.
- Air conditioning equipment should be grounded according to the local electrical regulations.
- Current leakage protection switch should be installed.
- Do not connect the power wire to the terminal of signal wire.
- When power wire is parallel with signal wire, put wires to their own wire tube and remain at least 300mm gap.
- According to table in indoor part named “the specification of the power” to choose the wiring, make sure the selected wiring not small than the date showing in the table.
- Select different colors for different wire according to relevant regulations.
- Do not use metal wire tube at the place with acid or alkali corrosion, adopt plastic wire tube to replace it.
- There must be not wire connect joint in the wire tube If joint is a must, set a connection box at the place.
- The wiring with different voltage should not be in one wire tube.
- Ensure that the color of the wires of outdoor and the terminal No. are same as those of indoor unit respectively.

11. Test operation

11.1 The test operation must be carried out after the entire installation has been completed.

11.2 Please confirm the following points before the test operation.

- The indoor unit and outdoor unit are installed properly.
- Tubing and wiring are correctly completed.
- The refrigerant pipe system is leakage-checked.
- The drainage is unimpeded.
- The ground wiring is connected correctly.
- The length of the tubing and the added stow capacity of the refrigerant have been recorded.
- The power voltage fits the rated voltage of the air conditioner.
- There is no obstacle at the outlet and inlet of the outdoor and indoor units.
- The gas-side and liquid-side stop valves are both opened.
- The air conditioner is pre-heated by turning on the power.

11.3 Test operation

Set the air conditioner under the mode of "COOLING" by remote controller, and check the following points.

Indoor unit

- Whether the switch on the remote controller works well.
- Whether the buttons on the remote controller works well.
- Whether the air flow louver moves normally.
- Whether the room temperature is adjusted well.
- Whether the indicator lights normally.
- Whether the temporary buttons works well.
- Whether the drainage is normal.
- Whether there is vibration or abnormal noise during operation.

Outdoor unit

- Whether there is vibration or abnormal noise during operation.
- Whether the generated wind, noise, or condensed of by the air conditioner have influenced your neighborhood.
- Whether any of the refrigerant is leaked.

Part 5

Electrical Control System

1. Electrical Control Function	97
2. Troubleshooting	109
3. Controller	143

1. Electrical Control Function

1.1 Abbreviation

T1: Indoor room temperature

T2: Middle indoor heat exchanger coil temperature

T2B: Indoor heat exchanger exhaust coil temperature

T3: Outdoor heat exchanger pipe temperature

T4: Outdoor ambient temperature

T5: Compressor discharge temperature

1.2 Main Protection

1.2.1 Compressor Restart Delay

1.2.2 Temperature Protection of Compressor Discharge

When the discharge temperature of compressor rises, the running frequency is limited according to the following rules:

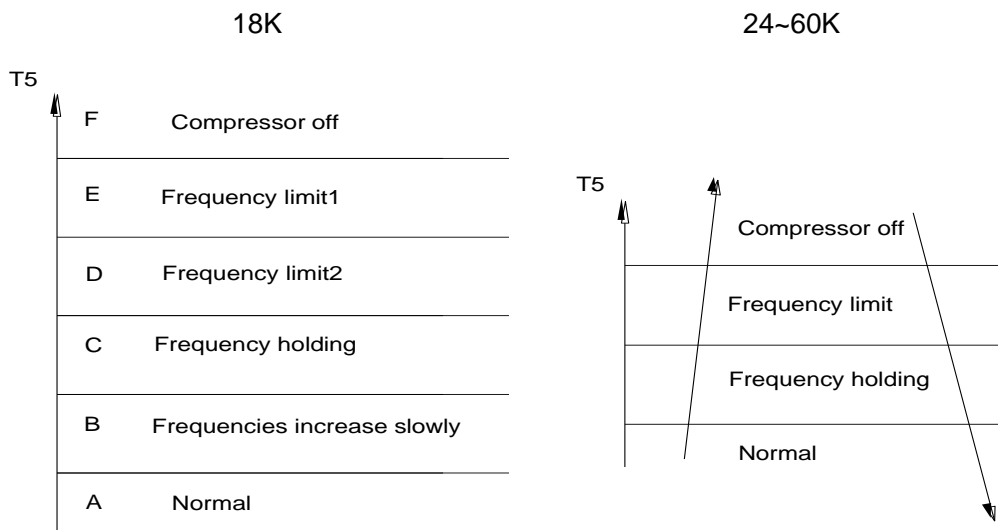

1.2.3 Indoor Fan Delayed Open Function

When the unit starts up, the louver is immediately active. The indoor fan opens 7 seconds later. If the unit runs in heating mode, the indoor fan is also regulated by the anti-cold wind function.

1.2.4 Fan Speed Malfunction

For A6 Duct:

If a fault occurs on the air volume regulator or the regulator enters protection mode, it sends the error message CF and an instruction to reduce fan speed to the master. The message and the instruction can be inquired with the remote controller or the wired controller. (Fault and protection information are displayed for one minute). After a fault occurs, the master unit shows the error code E3 and the fault count for one minute. If the fault occurs three times, then the fan is unable to resolve the problem independently. External shutdown by a remote controller, wired controller, or central controller must be used to clear the fan fault and fault count. The fan runs normally for 5 minutes while clearing fault count.

0: No malfunction
1: P0 Overcurrent
2: Overpressure
3: Overload
4: Over speed
5: Startup malfunction

6: Lack of phase
7: DC voltage too low
8: Communication fault
9: Parameter fault
10: L3 Current limited
11: L5 Voltage limited
12: Target speed cannot be met during the static pressure calculation process.

For other models:

If the indoor fan speed is lower than 300 RPM for 50 seconds or more, it shuts off and restarts in 30 seconds. If this happens 3 times, the unit stops and the LED displays the failure code.

1.3 Operation Modes and Functions

1.3.1 Fan Mode

- (1) Outdoor fan and compressor cease operation.
- (2) Temperature setting function is disabled, and no preset temperature is displayed.
- (3) Louver operates the same as in cooling mode.
- (4) Auto fan:
When it fan-only mode, operates the same as auto fan in cooling mode with the temperature set at 24°C.

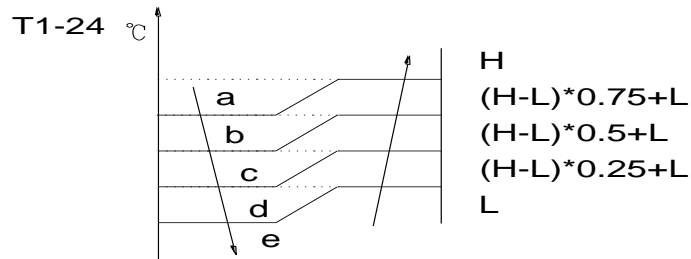

1.3.2 Cooling Mode

1.3.2.1 Outdoor Fan Running Guidelines

The outdoor unit can run at different fan speeds depending on T4.
 Fan speeds vary with the model of air conditioner.
 18K
 Fan speed is regulated according to T4 and compressor frequency.

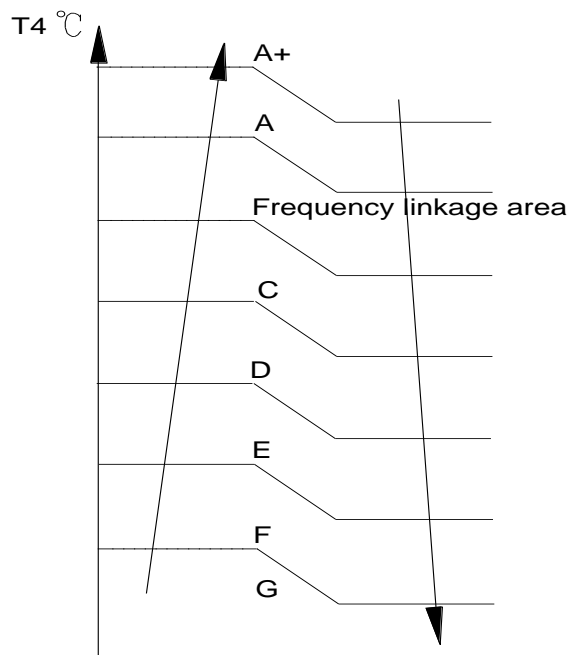

Frequency linkage area:

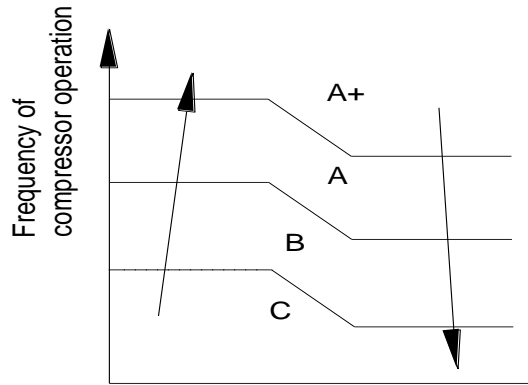

24~60K

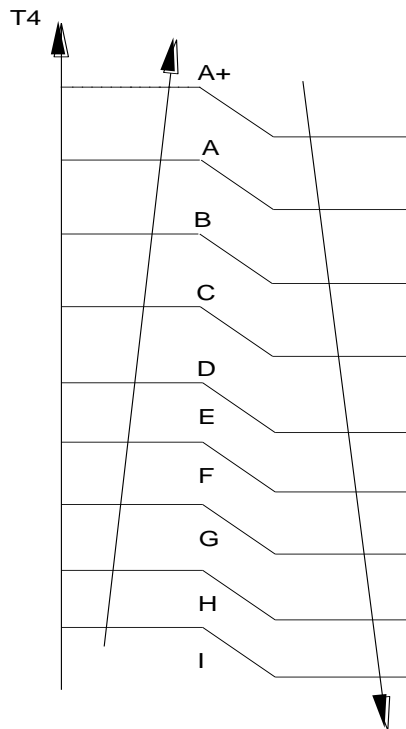

1.3.2.3 Indoor Fan Running Guidelines

In cooling mode, the indoor fan runs continuously and You can select the following speeds: high, medium, low, auto or silent. When the compressor is running, The indoor fan is regulated as illustrated as in the following figure:

Setting fan speed	T1-Td °C(°F)	Actual fan speed
H	A	H+ (H+=H+G)
	B	H (=H)
	C	H- (H-=H-G)
M	D	M+ (M+=M+Z)
	E	M (M=M)
	F	M- (M-=M-Z)
L	G	L+ (L+=L+D)
	H	L (L=L)
	I	L- (L-=L-D)

The auto fan in cooling mode acts as follows:

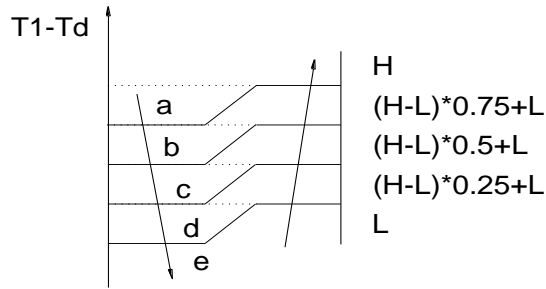

1.3.2.3 Evaporator Low Temperature T2 Protection.

- $T2 < 0^{\circ}C$, the compressor stops and restarts only when $T2 \geq 5^{\circ}C$.
- $0^{\circ}C \leq T2 < 4^{\circ}C$, the compressor frequency is limited and decreases to a lower level
- $4^{\circ}C \leq T2 < 7^{\circ}C$, the compressor maintains its current frequency.
- $T2 > 7^{\circ}C$, the compressor frequency is not limited.

1.3.2.4 High Condenser Coil Temperature Protection

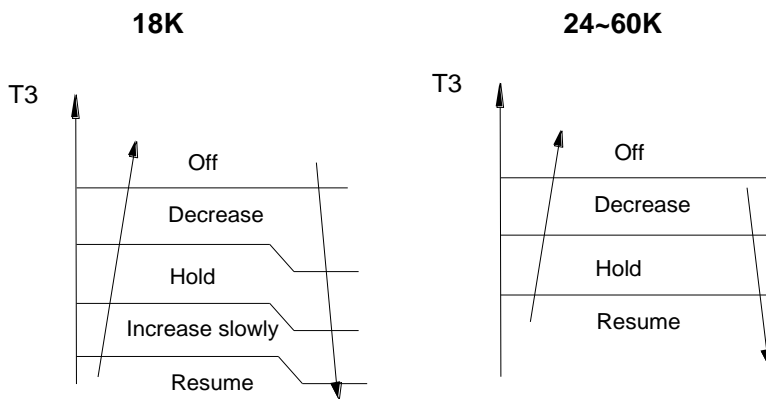

1.3.3 Heating Mode

1.3.3.1 Outdoor Fan Running Guidelines

18K

Fan speed is regulated according to T4 and compressor frequency.

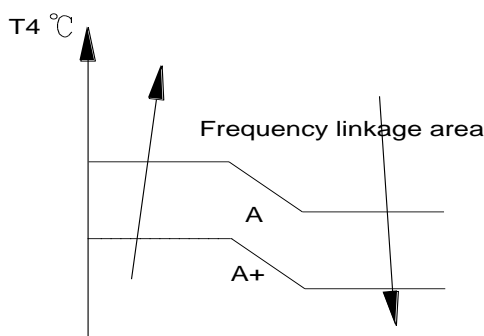

Frequency linkage area:

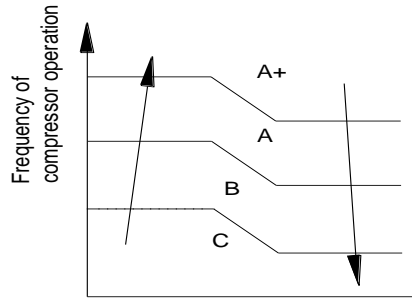

24~60K:

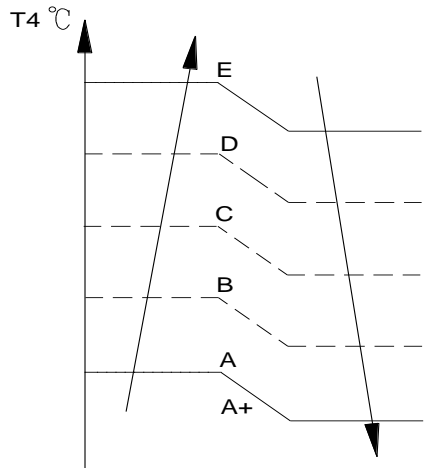

1.3.3.2 Indoor Fan Running Guidelines

In heating mode, indoor fan speed can be set at high, medium, low, or auto fan, and the anti-cold-wind function is preferential.

When the compressor is running, The indoor fan is regulated as illustrated as in the following figure:

Setting fan speed	T1-Td°C	Actual fan speed
H		H- (H=H-G)
		H (=H)
		H+(H+=H+G)
M		M-(M=M-Z)
		M(M=M)
		M+(M+=M+Z)
L		L-(L=L-D)
		L(L=L)
		L+(L+=L+D)

When the indoor temp reaches the preset temperature, the compressor stops and the indoor fan motor runs at the minimum speed (The anti-cold-wind is valid).

The auto fan in heating mode acts as follows:

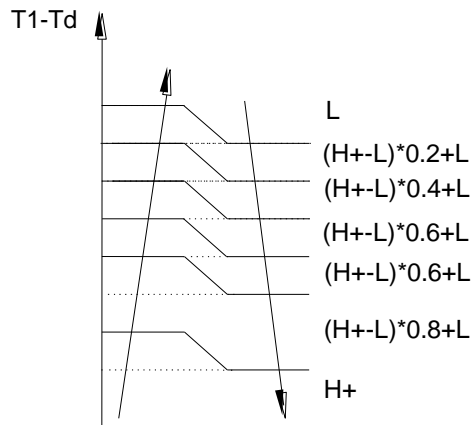

1.3.3.3 Defrosting Control:

Conditions for defrosting:

---the unit enters the defrosting mode according to the value of T3 and T4 as well as the compressor running time.

Defrost Stop Conditions:

If any one of the following conditions is satisfied, defrosting ends and the unit returns to heating mode.

---T3 rises above than TCDE1°C.

---T3 remains at TCDE2°C or above for 80 seconds.

---The machine runs for 10 consecutive minutes in defrosting mode.

1.3.3.4 High Evaporator Coil Temperature T2 Protection:

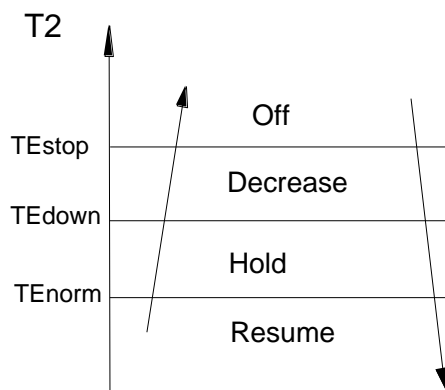

Off: Compressor stops.

Decrease: Decreases the running frequency.

Hold: Maintains the current frequency.

Resume: No limitation is applied to frequency.

1.3.4 Auto-mode

You can choose this mode with the remote control and adjust to temperature to between 17-30.

In auto mode, the machine chooses cooling, heating or fan-only mode according to ΔT ($\Delta T = T1 - Ts$).

$\Delta T = T1 - Ts$	Running mode
$\Delta T > 2^\circ\text{C}$	Cooling
$-2 < \Delta T \leq 2^\circ\text{C}$	Fan-only
$\Delta T \leq -2^\circ\text{C}$	Heating

The indoor fan runs at auto fan in each mode.

The louver operates the same in each mode.

If the machine switches mode between heating and cooling, the compressor stops for 15 minutes and then selects a mode again according to T1-Ts.

If the temperature is modified, the machine selects a running function.

1.3.5 Dehumidifier Mode

The indoor fan speed is fixed at breeze and can't be changed.

All protections are activated and operate the same as they do in cooling mode.

1.3.6 Timer Function

1.3.6.1 The timing range is 24 hours.

1.3.6.2 Timer On. The machine turns on automatically at the preset time.

1.3.6.3 Timer Off. The machine turns off automatically at the preset time.

1.3.6.4 Timer On/Off. The machine turns on automatically at the preset On Time, and then turns off automatically at the preset Off Time.

1.3.6.5 Timer Off/On. The machine turns on automatically at the preset Off Time and then turns off automatically at the preset On Time.

1.3.6.6 The timer does not change the unit operation mode. If the unit is off now, it does not start up immediately after the "timer off" function is set. When the setting time is reached, the timer LED switches ioff and the unit running mode remains unchanged.

1.3.6.7 The timer uses relative time, not clock time.

1.3.7 Sleep Mode

1.3.7.1 The sleep function is available in cooling, heating or auto mode.

1.3.7.2. The operational process in sleep mode is as follows:

When cooling, the temperature rises 1°C (to not higher than 30°C) every hour, 2 hours later the temperature stops rising and the indoor fan is fixed to low speed.

When heating, the temperature decreases 1°C (to not lower than 17°C) every hour, 2 hours the temperature stops decreasing and the indoor fan is fixed at low speed. (Anti-cold wind function takes priority).

1.3.7.3 Sleep mode lasts a maximum of 7 hours. After 7 hours, the unit does not switch off., but for console, the unit switches off.

1.3.7.4 The timer uses relative time, not clock time.

1.3.8 Auto-Restart Function

The indoor unit has an auto-restart module that allows the unit to restart automatically. The module automatically stores the current settings (not including the Swing setting) and, in the case of a sudden power failure, will restore those setting automatically within 3 minutes after power returns.

1.3.9 Drain Pump Control (For Duct and Cassette)

Use the water-level switch to control drain pump.

The system checks the water level every 5 seconds.

---When the A/C operates in cooling (including auto cooling) or forced cooling mode, the pump begins running immediately and continuously until cooling stops.

---If the water level increases up to the control point, the LED displays an alarm code and the drain pump opens and continually monitors the water level. If the water level falls and LED alarm code is no longer displayed (drain pump close delay is 1 minute), the unit goes back into its last mode. Otherwise, the entire system (including the pump) stops and the LED displays an alarm again after 3 minutes.

1.3.10 Follow Me(Optional)

If you press "Follow Me" on the remote, the indoor unit will beep. This indicates the follow me function is active.

Once active, the remote control will send a signal every 3 minutes, with no beeps. The unit automatically sets the temperature according to the measurements from the remote control.

The unit will only change modes if the information from the remote control makes it necessary, not from the unit's temperature setting.

1.3.11 Outdoor Unit Point Check Function(Excluding 12K&18K models)

A check switch is included on the outdoor PCB.

Push SW1 to check the unit's status while running. The digital display shows the following codes each time the SW1 is pushed.

N	Display	Remark
00	Normal display	Displays running frequency, running state, or malfunction code
01	Indoor unit capacity demand code	Actual data*HP*10 If a capacity demand code is higher than 99, the digital display shows single and double digits. For example, if the digital display shows "5.0", the capacity demand is 15. If the digital display tube shows "60", the capacity demand is 6.0.
02	Amendatory capacity demand code	
03	The frequency after the capacity requirement transfer	
04	The frequency after the frequency limit	
05	The frequency of sending to 341	
06	Indoor unit evaporator outlet temperature (heating T2, cooling T2B)	If the temperature is lower than -9 °C, the digital display shows "-9." If the temperature is higher than 70 °C, the digital display shows "70." If the indoor unit is not connected, the digital display shows: "——"
07	Condenser pipe temperature (T3)	
08	Outdoor ambient temperature (T4)	
09	Compressor discharge temperature (T5)	The display value is between 0–129 °C. If the temperature is higher than 99 °C, the digital display shows single and double digits. For example, if the digital display shows "0.5", the compressor discharge temperature is 105 °C. If the digital display shows "1.6," the compressor discharge temperature is 116 °C.
10	AD value of current	The display value is a hexadecimal number.
11	AD value of voltage	
12	Indoor unit running mode code	Off:0, Fan only: 1, Cooling: 2, Heating: 3, Forced cooling: 4, Dry: 6, Self-clean: 8, Forced defrosting: 10
13	Outdoor unit running mode code	Off:0, Fan only: 1, Cooling: 2, Heating: 3, Forced cooling: 4, Dry: 6, Self-clean: 8, Forced defrosting:10
14	EXV open angle	Actual data/4.

		If the value is higher than 99, the digital display shows single and double digits. For example, if the digital display shows "2.0", the EXV open angle is 120×4=480p.																	
15	Frequency limit symbol	<table border="1"> <tr> <td>Bit7</td> <td>Frequency limit caused by IGBT radiator</td> <td rowspan="8">The display value is a hexadecimal number. For example, the digital display show 2A, then Bit5=1, Bit3=1, and Bit1=1. It means frequency limit may be caused by T4, T3 or the current.</td> </tr> <tr> <td>Bit6</td> <td>Frequency limit caused by PFC</td> </tr> <tr> <td>Bit5</td> <td>Frequency limit caused by T4.</td> </tr> <tr> <td>Bit4</td> <td>Frequency limit caused by T2.</td> </tr> <tr> <td>Bit3</td> <td>Frequency limit caused by T3.</td> </tr> <tr> <td>Bit2</td> <td>Frequency limit caused by T5.</td> </tr> <tr> <td>Bit1</td> <td>Frequency limit caused by current</td> </tr> <tr> <td>Bit0</td> <td>Frequency limit caused by voltage</td> </tr> </table>	Bit7	Frequency limit caused by IGBT radiator	The display value is a hexadecimal number. For example, the digital display show 2A, then Bit5=1, Bit3=1, and Bit1=1. It means frequency limit may be caused by T4, T3 or the current.	Bit6	Frequency limit caused by PFC	Bit5	Frequency limit caused by T4.	Bit4	Frequency limit caused by T2.	Bit3	Frequency limit caused by T3.	Bit2	Frequency limit caused by T5.	Bit1	Frequency limit caused by current	Bit0	Frequency limit caused by voltage
Bit7	Frequency limit caused by IGBT radiator	The display value is a hexadecimal number. For example, the digital display show 2A, then Bit5=1, Bit3=1, and Bit1=1. It means frequency limit may be caused by T4, T3 or the current.																	
Bit6	Frequency limit caused by PFC																		
Bit5	Frequency limit caused by T4.																		
Bit4	Frequency limit caused by T2.																		
Bit3	Frequency limit caused by T3.																		
Bit2	Frequency limit caused by T5.																		
Bit1	Frequency limit caused by current																		
Bit0	Frequency limit caused by voltage																		
16	DC fan motor speed	0: Off, 1: Turbo, 2: High, 3: Medium, 4: Low, 5: Breeze, 6: Supper breeze																	
17	IGBT radiator temperature	The display value is between 0–30 °C. If the temperature is higher than 99 °C, the digital display shows single and double digits. For example, if the digital display shows "0.5", the IGBT radiator temperature is 105 °C. If the digital display shows "1.6", the IGBT radiator temperature is 116 °C.																	
18	Indoor unit number	The indoor unit can communicate with outdoor unit. General: 1, Twins: 2																	
19	Condenser pipe temperature of #1 indoor unit	If the temperature is lower than 0 °C, the digital display shows "0". If the temperature is higher than 70 °C, the digital display shows "70."																	
20	Condenser pipe temperature of #2 indoor unit																		
21	Reserved	If the capacity demand is 0, the digital display shows "0". If the indoor unit is not connected, the digital display shows: "___"(heating T2, cooling T2B)																	
22	#1 Indoor unit capacity demand code	Actual data*HP*10																	
23	#2 Indoor unit capacity demand code																		
24	Reserved	If a capacity demand code is higher than 99, the digital display shows single and double digits. For example, if the digital display reads "5.0", the capacity demand is 15. If the digital display shows "60", the capacity demand is 6.0. If the indoor unit is not connected, the digital display shows: "___"																	
25	Indoor room temperature of #1 indoor unit	If the temperature is lower than -9 °C, the digital display shows "9". If the temperature is higher than 70 °C, the digital display shows "70". If the capacity demand is 0, the digital display shows "0". If the indoor unit is not connected, the digital display shows: "___"																	
26	Indoor room temperature of #2 indoor unit	If the temperature is lower than 0 °C, the digital display shows "0". If the temperature is higher than 70 °C, the digital display shows "70". If the capacity demand is 0, the digital display shows "0".																	

		If the indoor unit is not connected, the digital display shows: “___”
27	Average of indoor room temperature	If the temperature is lower than 0 °C, the digital display shows “0”. If the temperature is higher than 70 °C, the digital display shows “70”.
28	Shutdown cause	Refer to Appendix
29	T2B of #1 indoor unit	If the temperature is lower than -9 °C, the digital display shows “9”. If the temperature is higher than 70 °C, the digital display shows “70”. If the capacity demand is 0, the digital display shows “0”. If the indoor unit is not connected, the digital display shows: “___”
30	T2B of #2 indoor unit	If the temperature is lower than 0 °C, the digital display shows “0”. If the temperature is higher than 70 °C, the digital display shows “70”. If the capacity demand is 0, the digital display shows “0”. If the indoor unit is not connected, the digital display shows: “___”

Appendix

Shutdown Causes	Code
Frequency limit caused by current	1
Frequency limit caused by T2 in cooling	2
Frequency limit caused by T2 in heating	3
Preset temperature reached	4
Frequency limit caused by T4	5
Defrosting	6
Mode switching	7
High discharge temperature protection	9
High evaporator coil temperature T2 protection	10
Evaporator low temperature T2 protection	11
Condenser high temperature T3 protection	12
Low indoor room temperature protection in drying mode	13
Low ambient temperature protection	14
Refrigerant leakage detection	15
Communication malfunction between indoor and outdoor units	16
Communication error between outdoor main chip and compressor driven chip IR341	17
AC power input voltage protection	18
Top temperature protection of compressor	19
Outdoor EE Malfunction	20
Fan speed malfunction	21
Temperature sensor open or short circuit	22
Overcurrent protection	23
IMP overcurrent protection	24
Compressor lack of phase	25
Compressor malfunction	26
Low pressure protection of 311	27
Fan current protection	28
Fan lack of phase	29
Fan zero speed protection	30
PFC module protection	31
High pressure protection of 311	32
Zero speed malfunction	33
PWM malfunction	34
MCE malfunction	35

Compressor overcurrent protection	36
Compressor EE malfunction	37
Compressor start-up malfunction	38
311 fan speed has been malfunction	39
Low pressure protection	40
High pressure protection	41
PFC module malfunction	42
Shutdown stop	49
Electrical disconnect	50
DR stop	51

2. Troubleshooting

2.1 Display board

2.1.1 Icon explanation on indoor display board (Super slim cassette).

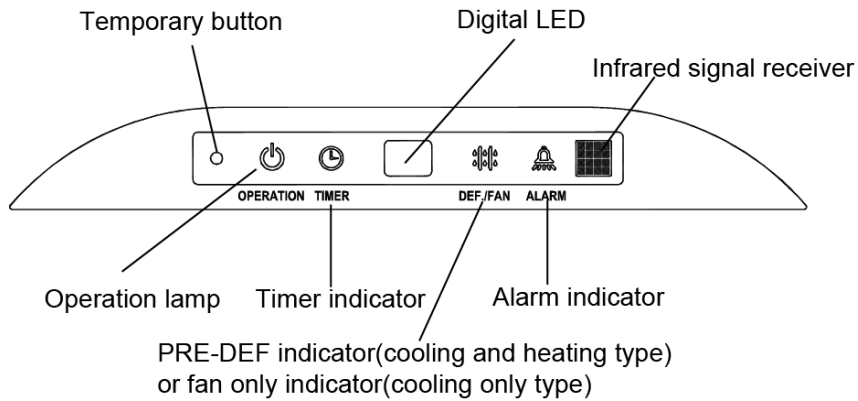

2.1.2 Icon explanation on indoor display board (A6 Duct)

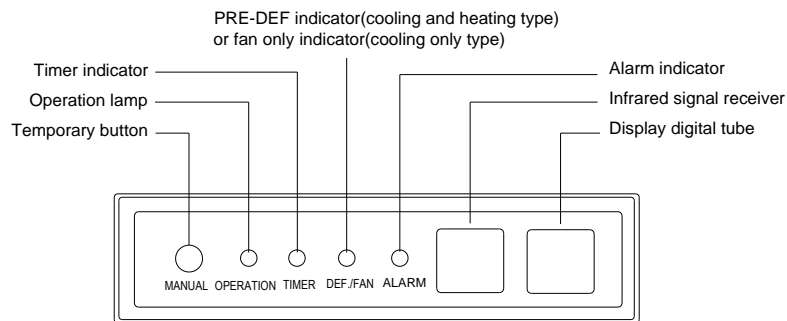

2.1.3 Auto-lifting panel of 4 way cassette

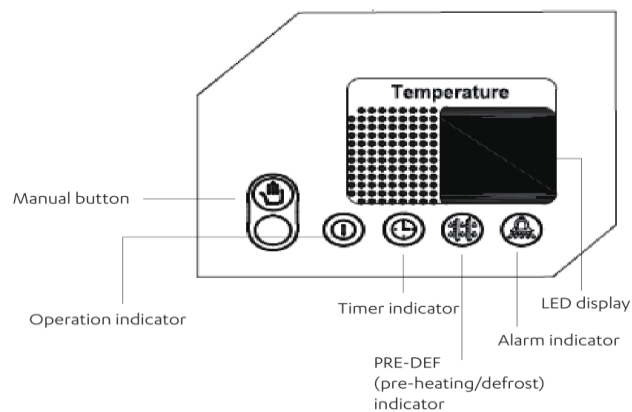

2.1.4 Display board of Ceiling-floor indoor unit



2.2 Indoor Unit Malfunctions

Malfunction	Error Code	Timer Lamp	Operation Lamp (flashes)
Indoor EEPROM malfunction	E0	X	1
Communication malfunction between indoor and outdoor units	E1	X	2
Indoor fan speed malfunction	E3	X	4
T1 temperature sensor open or short circuit	E4	X	5
T2 temperature sensor open or short circuit	E5	X	6
Refrigerant leakage detection	EC	X	7
Water level alarm malfunction	EE	X	8
Communication error between master and slave unit (for twins system)	E8	X	9
Another indoor unit malfunction (for twins system)	E9	X	10
Outdoor unit is faulty (for old communication protocol)	Ed	X	11
Overcurrent protection (for some units)	F0	O	1
T4 temperature sensor open or short circuit	F1	O	2
T3 temperature sensor open or short circuit	F2	O	3
T5 temperature sensor open or short circuit	F3	O	4
Outdoor EEPROM malfunction (for some units)	F4	O	5
Outdoor fan speed malfunction	F5	O	6
T2B temperature open or short circuit (for free-match indoor units)	F6	O	7
Communication error between auto-lifting panel and slim cassette	F7	O	8
Auto-lifting panel is faulty (for slim cassettes with an auto-lifting panel)	F8	O	9
Auto-lifting panel is not closed (for slim cassettes with an auto-lifting panel)	F9	O	10
IPM module malfunction	P0	☆	1
DC voltage too high/too low protection	P1	☆	2
Top of compressor high temperature protection	P2	☆	3
Low ambient temperature protection	P3	☆	4
Inverter compressor drive protection	P4	☆	5
Compressor low pressure protection	P6	☆	7
Outdoor IGBT sensor is faulty	P7	☆	8
O (on) X(off) ☆(flash at 2Hz)			

2.3 Outdoor Unit Malfunctions

For 24K~60K:

Display	Malfunction or Protection
E1	Communication malfunction between indoor and outdoor units
F0	Overcurrent protection
F1	Ambient temperature sensor (T4) malfunction
F2	Outdoor heat-exchanger temperature sensor (T3) malfunction
F3	Discharge temperature sensor (T5) malfunction
F4	Outdoor EEPROM malfunction
F5	Outdoor fan speed malfunction
P0	IPM module protection
P1	DC voltage too high/too low protection
P3	Ultra-low ambient temperature protection
P4	Compressor rotor position protection
J0	Evaporator high temperature protection
J1	Condenser high temperature protection
J2	High discharge temperature protection
J3	PFC module protection
J4	Communication error between outdoor main chip and compressor driven chip
J5	High pressure protection
J6	Low pressure protection
P7	IGBT sensor malfunction
J8	AC power input voltage protection

In low ambient cooling mode, the LED displays “LC” or alternates between running frequency and “LC” (each appears for 0.5s).

2.4 Resolving Typical Malfunctions

2.4.1 For Indoor Units

2.4.1.1 Temperature Sensor Open or Short Circuit

Malfunction conditions	If the sampling voltage is lower than 0.06V or higher than 4.94V, the LED will display the failure.
Possible causes	<ul style="list-style-type: none"> ● Wiring mistakes ● Faulty sensor ● Faulty PCB

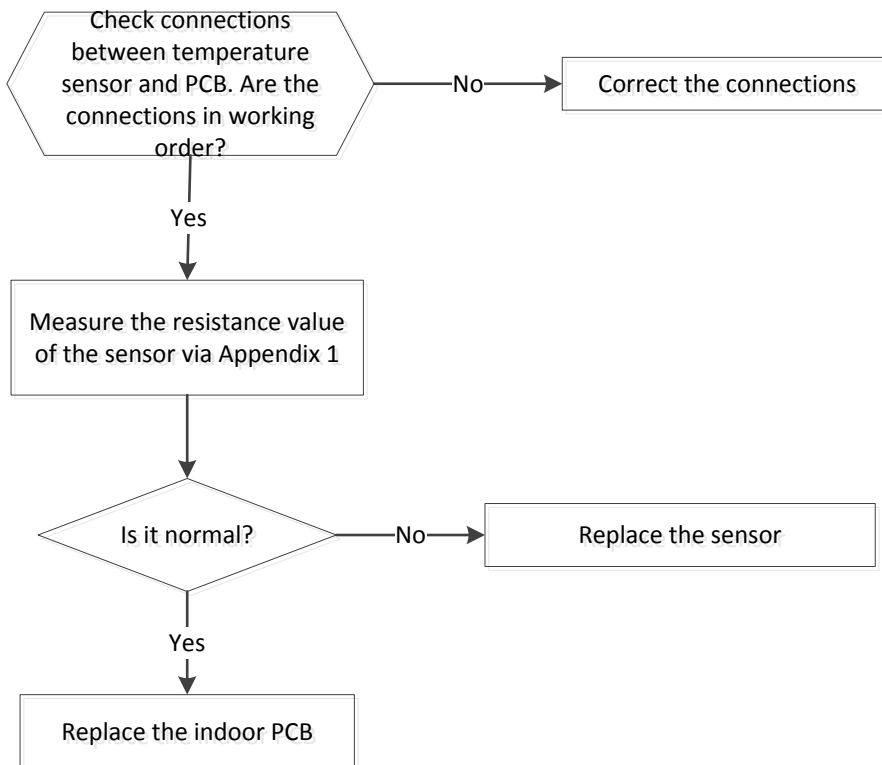

2.4.1.2. Outdoor Unit Malfunction

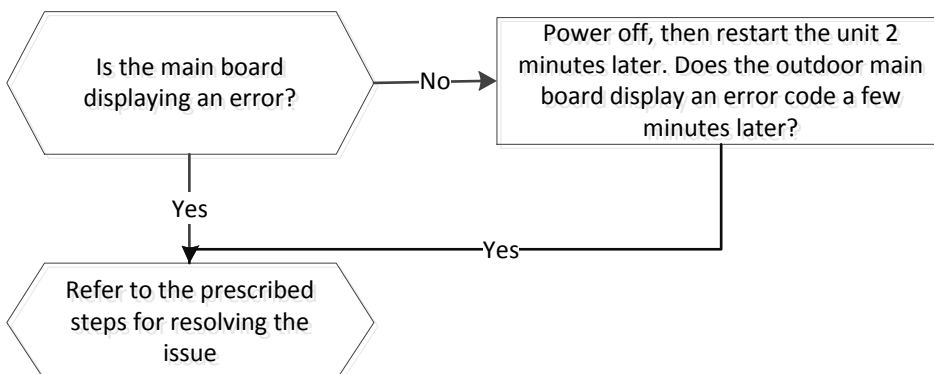

2.4.1.3. Indoor EEPROM Malfunction

Malfunction conditions	Main PCB chip does not receive feedback from EEPROM chip
Possible causes	<ul style="list-style-type: none"> ● Installation mistakes ● Faulty PCB

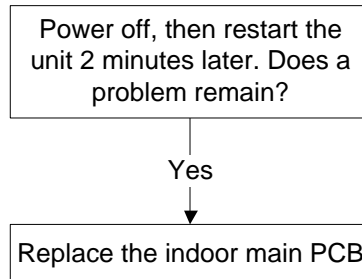

EEPROM: An electrically erasable programmable read-only memory whose contents can be erased and reprogrammed using a pulsed voltage.

2.4.1.4. Water-Level Alarm Malfunction

Malfunction conditions	If the sampling voltage is not 5V, the LED will display the failure code.
Possible causes	<ul style="list-style-type: none"> ● Wiring mistakes ● Faulty water-level switch ● Faulty water pump ● Faulty indoor PCB

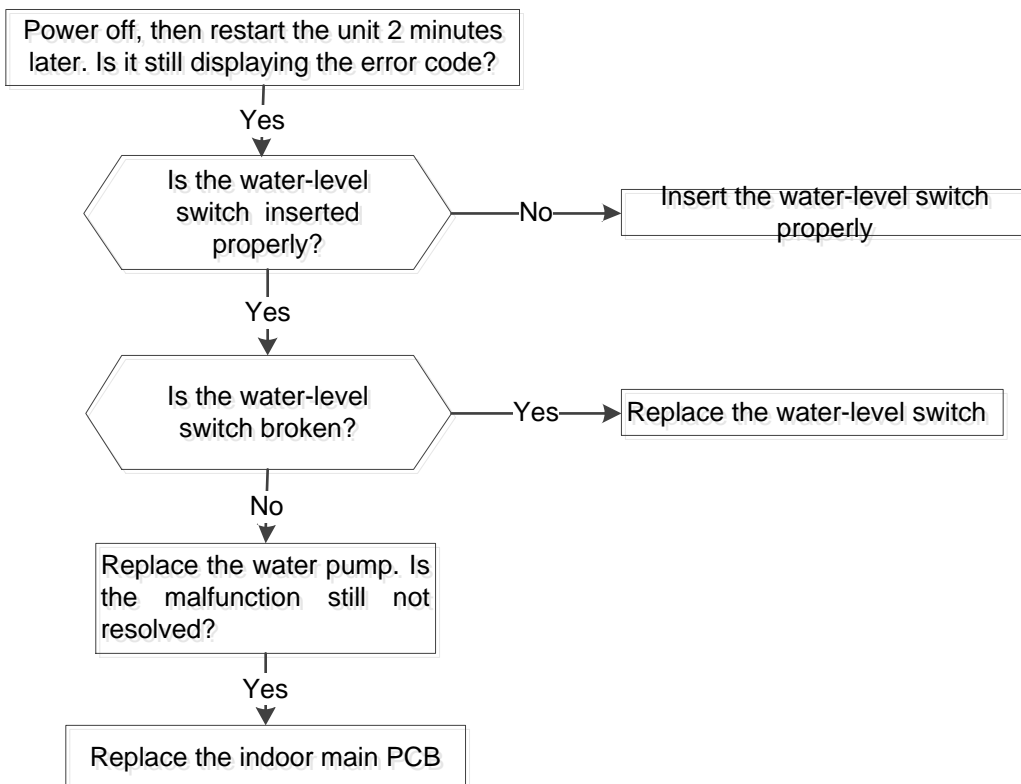

2.4.1.5. Indoor Fan Speed Malfunction

Malfunction conditions	When indoor fan speed continues to run at too low a speed (300RPM) for a certain period of time, the unit will stop and the LED will display a failure code.
Possible causes	<ul style="list-style-type: none"> ● Wiring mistakes ● Faulty fan assembly ● Faulty fan motor ● Faulty PCB

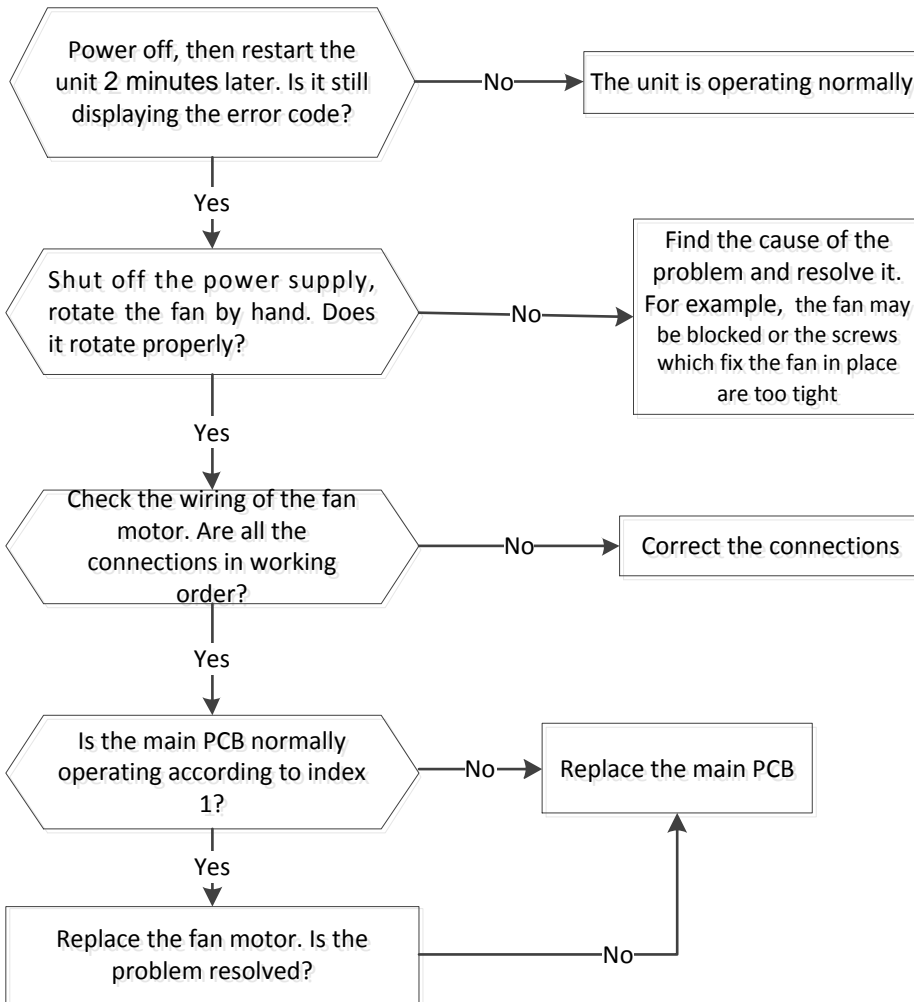

Index 1:

1. Indoor DC fan motor (control chip is located inside the fan motor)

Power on and when the unit is on standby, measure the voltage of pin1-pin3, pin4-pin3 in the fan motor connector. If the value of the voltage is not within the range shown in the following table, the PCB may be experiencing problems and may need to be replaced.

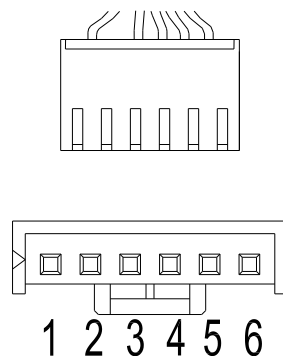

DC motor voltage input and output

NO.	Color	Signal	Voltage
1	Red	Vs/Vm	200V~380V
2	---	---	---
3	Black	GND	0V
4	White	Vcc	13.5-16.5V
5	Yellow	Vsp	0~6.5V
6	Blue	FG	13.5-16.5V

2.4.1.6. Refrigerant Leakage Detection

Malfunction conditions	<p>Define the evaporator coil temperature T2 of the compressor starts running as Tcool.</p> <p>If the following occurs 3 times, the display shows "EC" and the unit switches off:</p> <p>In the first 8 minutes after the compressor starts up, if $T2 < T_{cool} - 2^{\circ}\text{C}$ is not maintained for 4 seconds and compressor running frequency is not higher than 50Hz for 3 minutes</p>
Potential causes	<ul style="list-style-type: none"> ● T2 sensor error ● Indoor PCB error ● Refrigerant system error, such as leakage or blockages

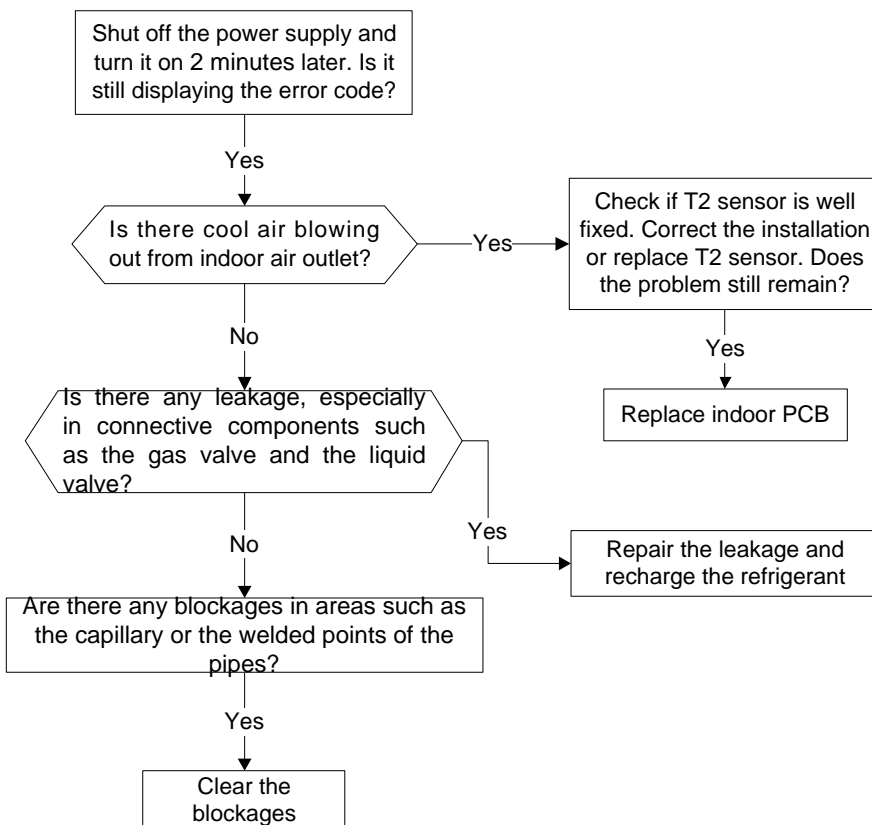

2.4.1.7 Outdoor IGBT sensor is faulty

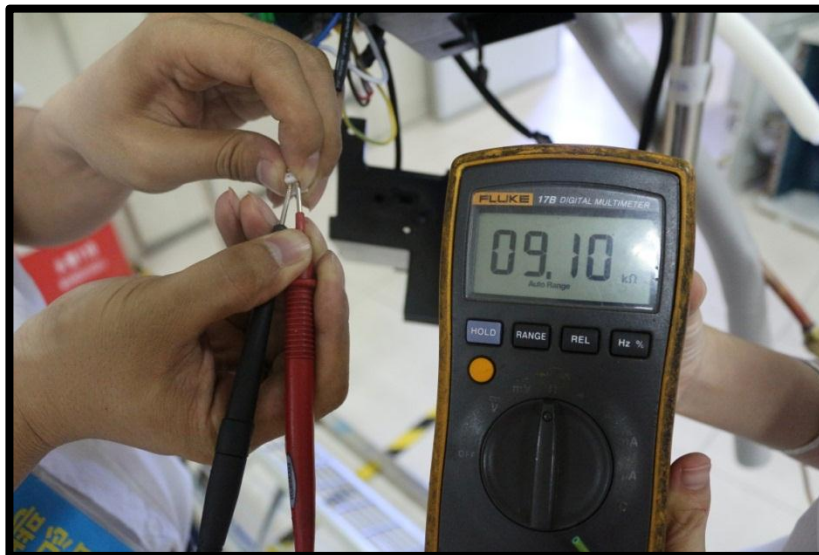
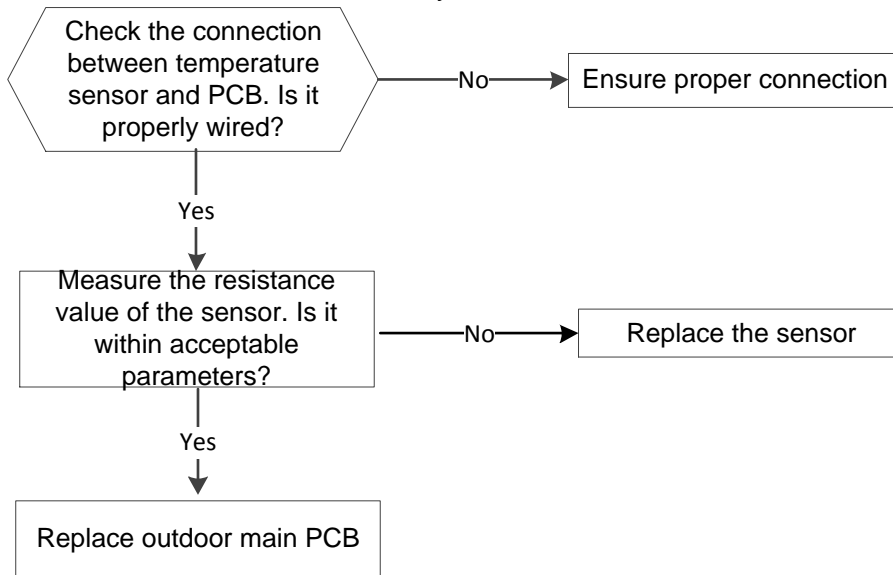

2.4.1.8 Communication malfunction between indoor and outdoor units
The same as E1 in outdoor.

2.4.2 Super-Slim Cassettes with an Up-Down Panel

2.4.2.1 Communication Errors between Indoor Unit and Up-Down Panel

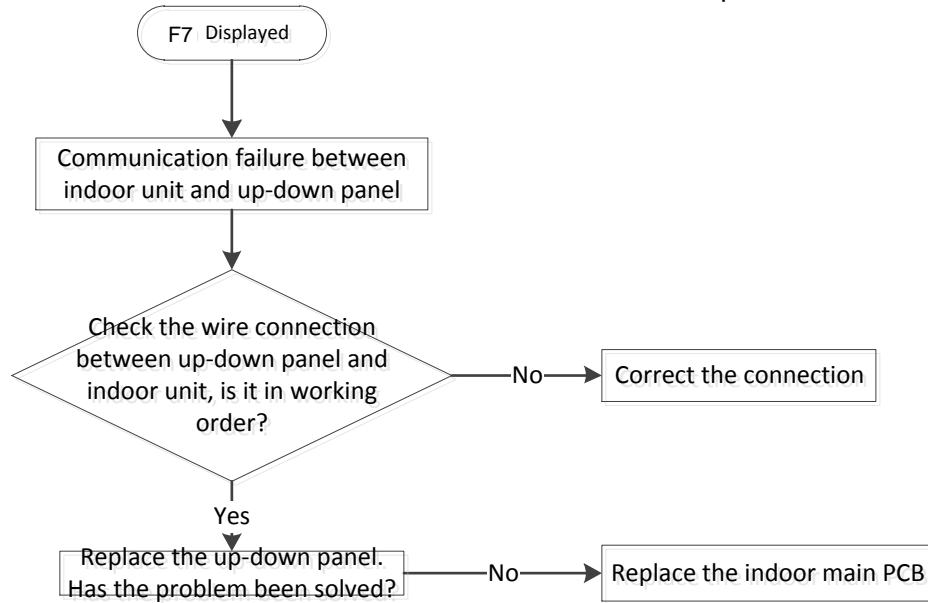

2.4.2.2 Up-down panel is defective

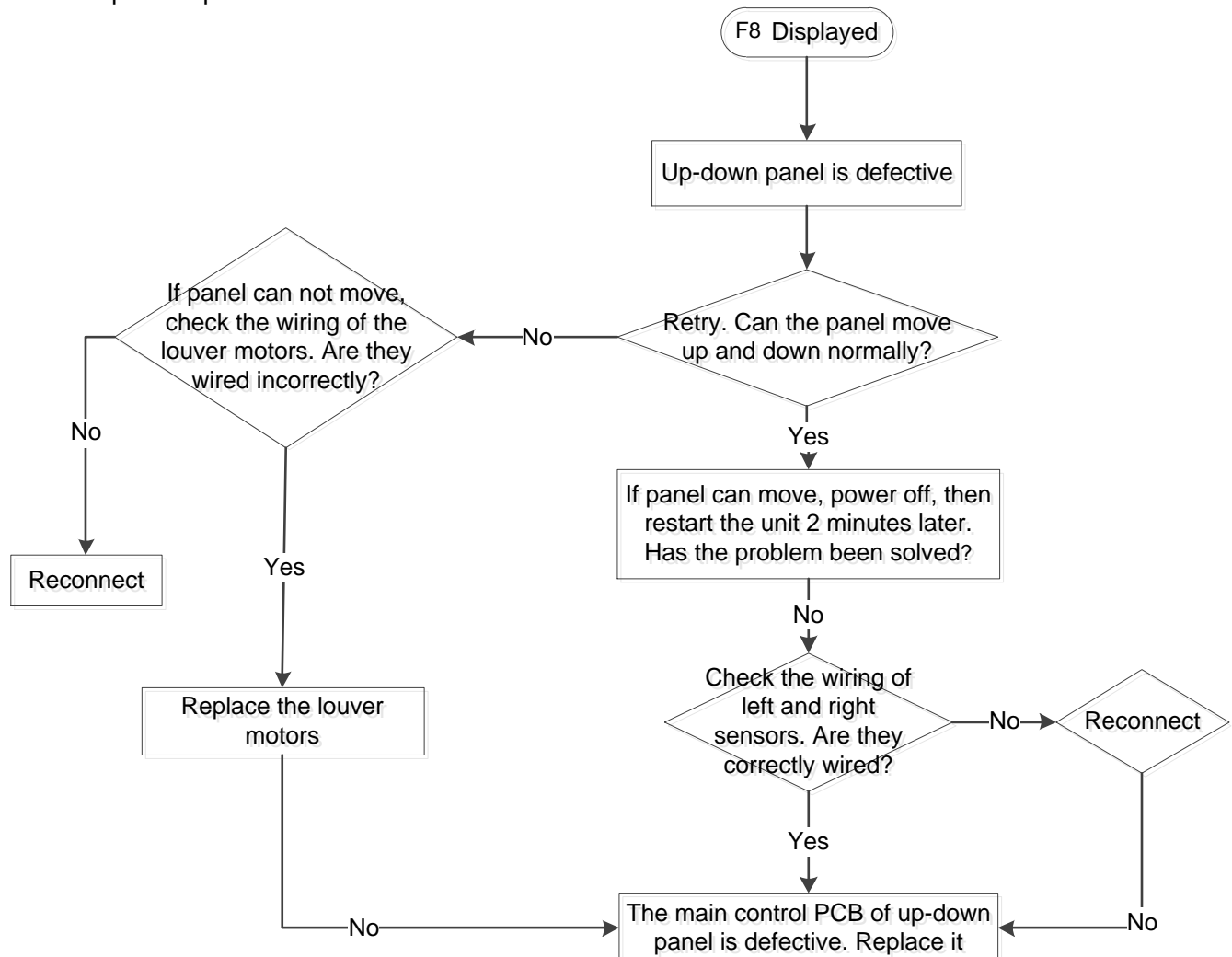

2.4.3 Units with TWINS Function (for the Super-Slim Cassette & A5 Duct)

2.4.3.1 Communication Malfunction between Master Unit and Indoor Unit

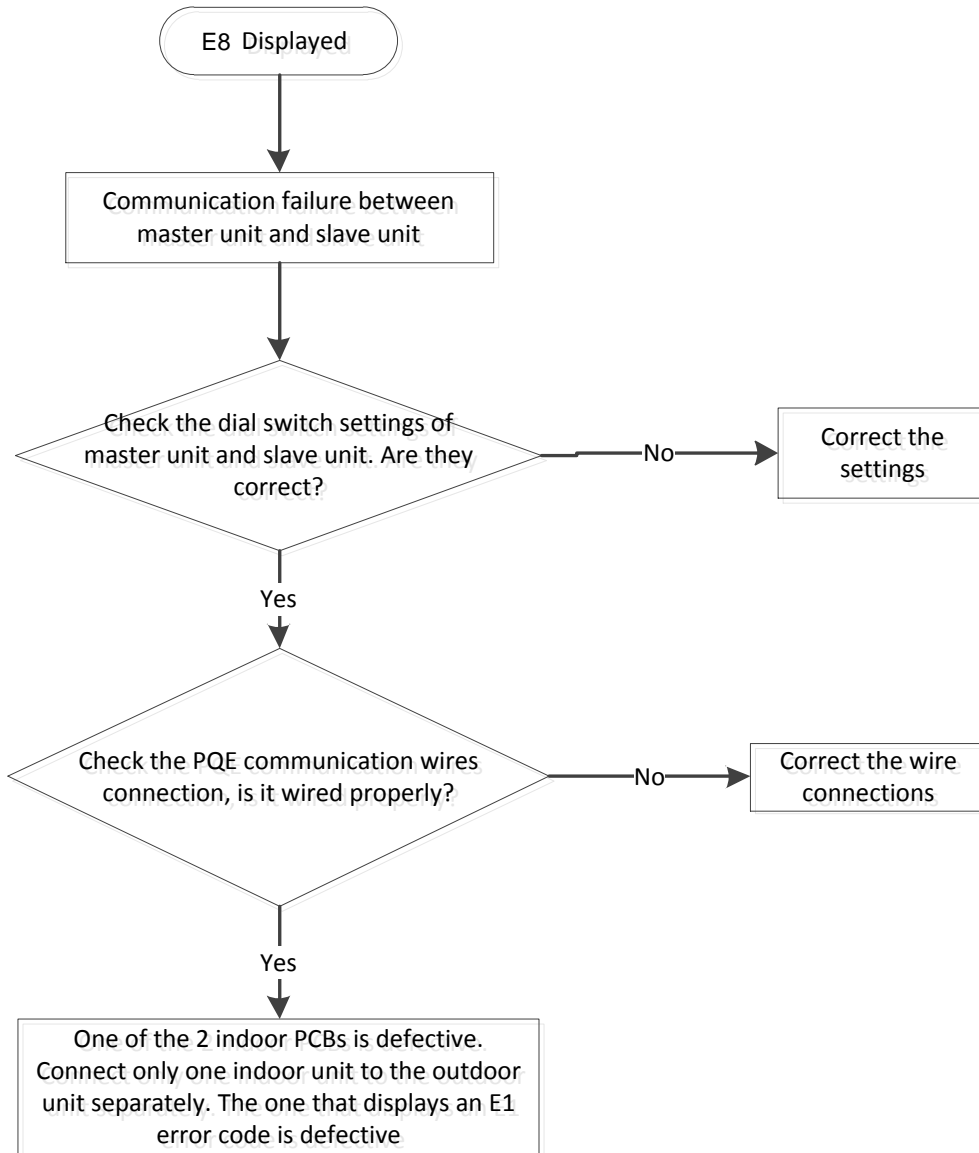

2.4.3.2 Other Malfunction between Master Unit and Indoor Unit

One indoor unit displays "E9", which means the other indoor unit is faulty. Check the other indoor unit's error code and then follow the prescribed solutions to resolve the malfunction.

2.4.4 Outdoor Units

2.4.4.1. Compressor Driven Chip EEPROM Malfunction

Malfunction conditions	Main PCB chip does not receive feedback from EEPROM chip
Possible causes	<ul style="list-style-type: none"> ● Installation mistakes ● Faulty PCB

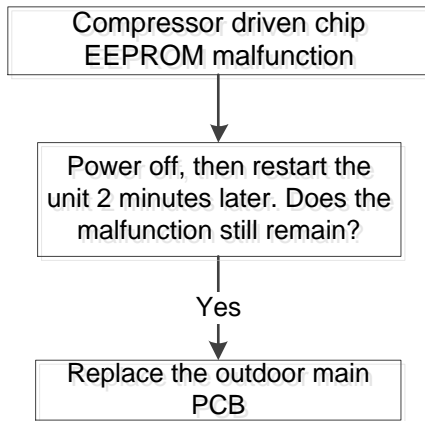

2.4.4.2 Compressor Speed Malfunction/ Zero Speed Protection / Synchronous Fault Protection

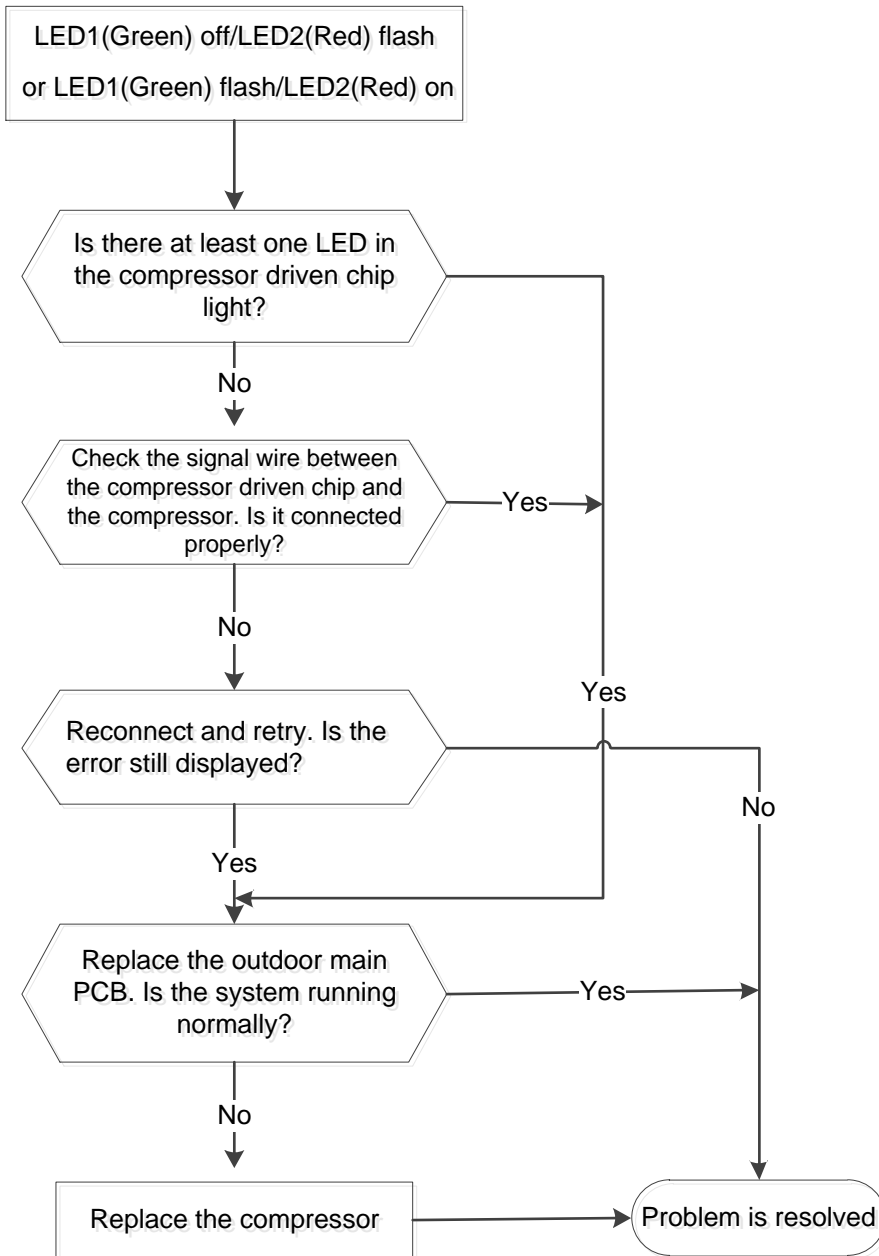

2.4.4.3 MCE Malfunction

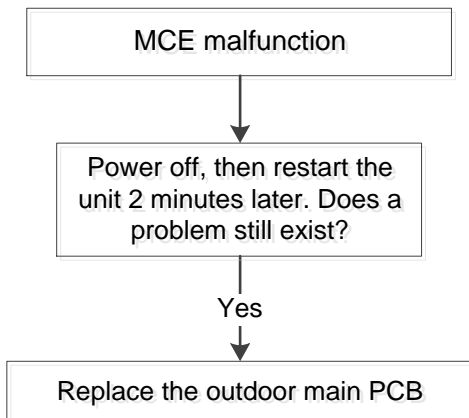

2.4.4.4. E1 malfunction

Current loop communication:

Malfunction conditions	Indoor unit does not receive feedback from outdoor unit for 110 seconds. This occurs 4 times in a row.
Possible causes	<ul style="list-style-type: none"> ● Wiring mistakes ● Faulty indoor or outdoor PCB

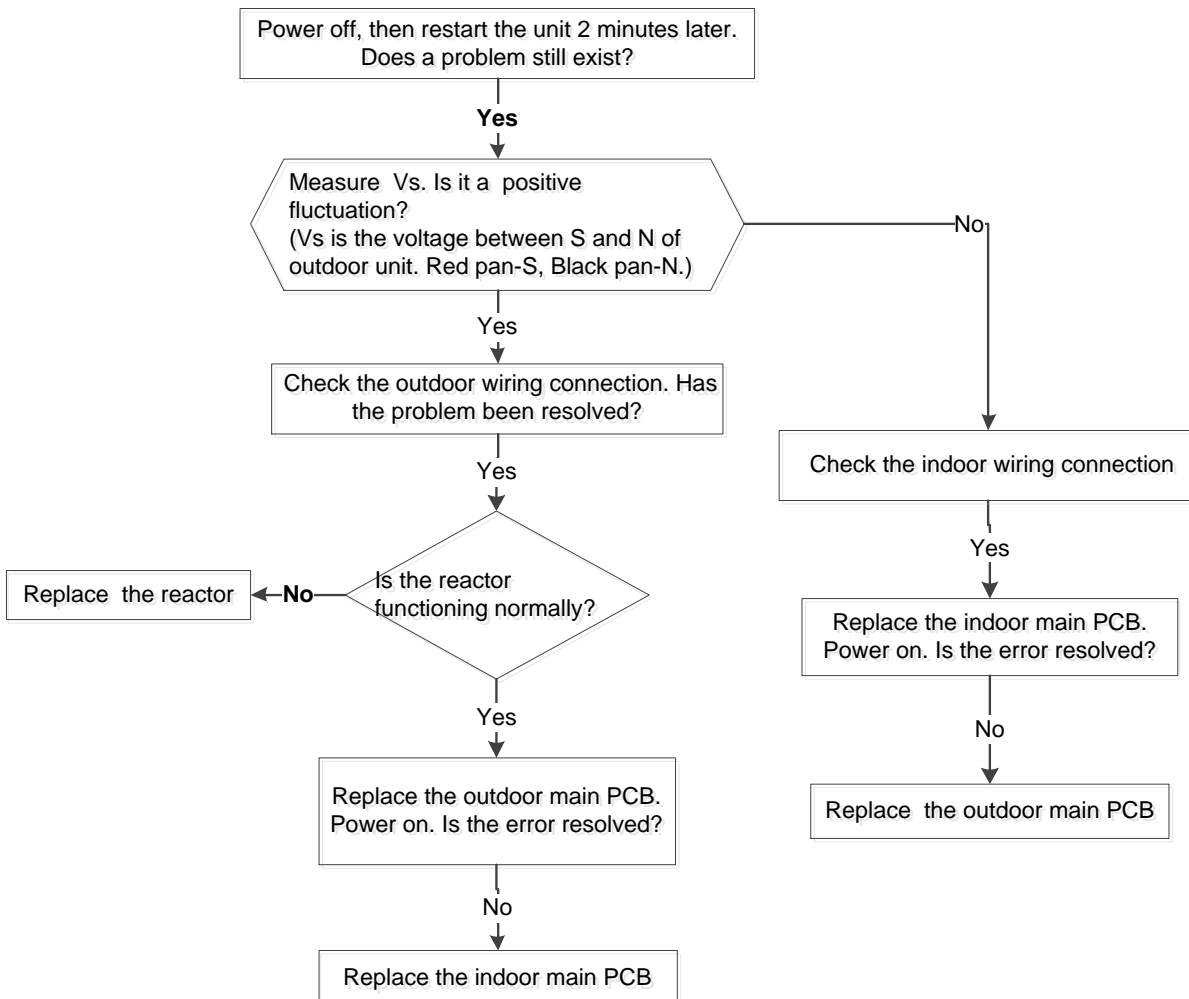

For 485 Communication

Malfunction conditions	Indoor unit does not receive feedback from outdoor unit for 60 seconds OR outdoor unit does not receive feedback from indoor unit for 120 seconds.
Possible causes	<ul style="list-style-type: none"> ● Wiring mistakes ● Faulty indoor or outdoor PCB

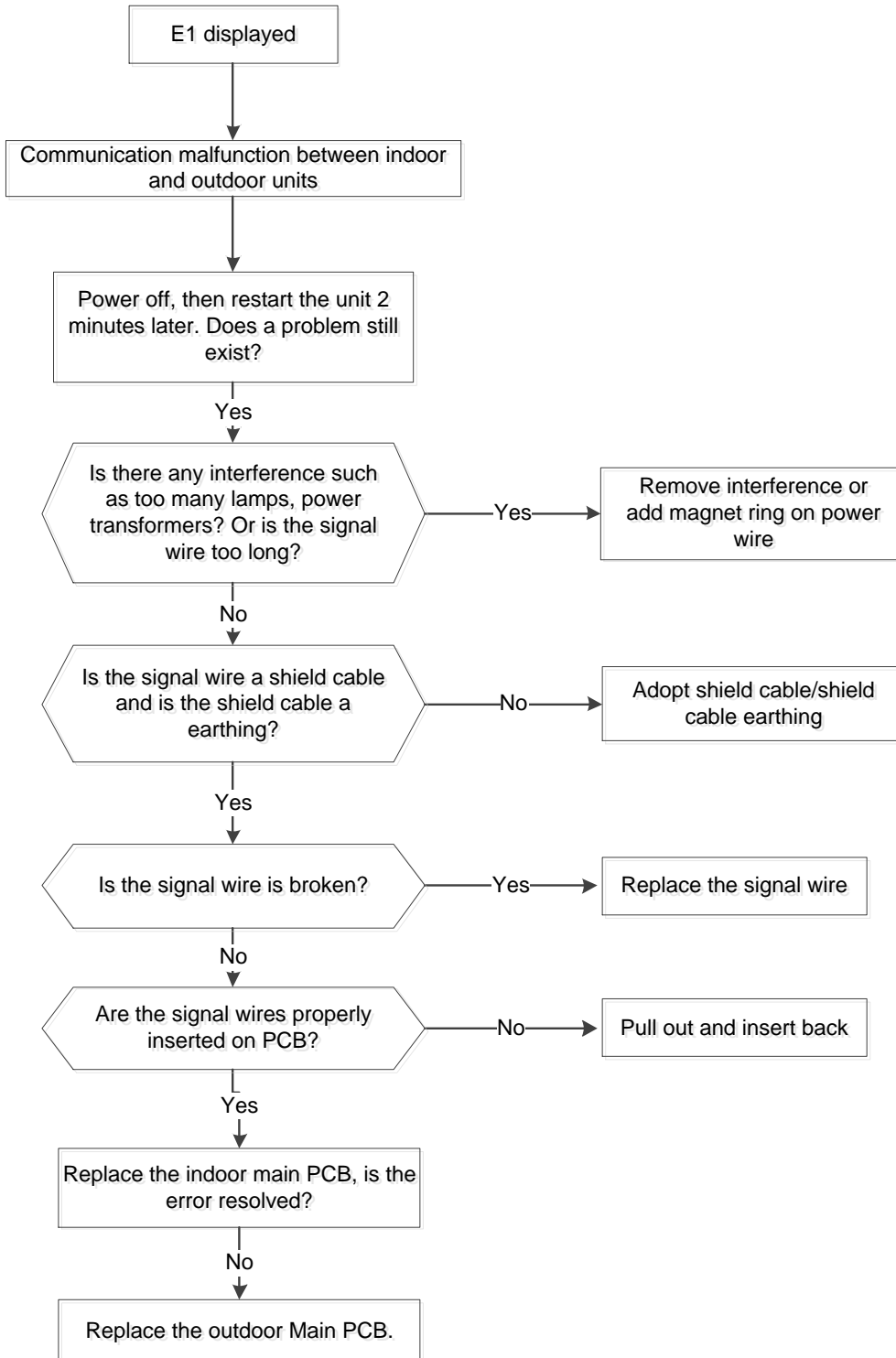

2.4.4.5. F0 Malfunction

Malfunction conditions	If the outdoor current exceeds the current limit value, the LED displays a failure code.
Possible causes	<ul style="list-style-type: none">● Wiring mistakes● Faulty bridge rectifier● System blockages● Faulty outdoor PCB

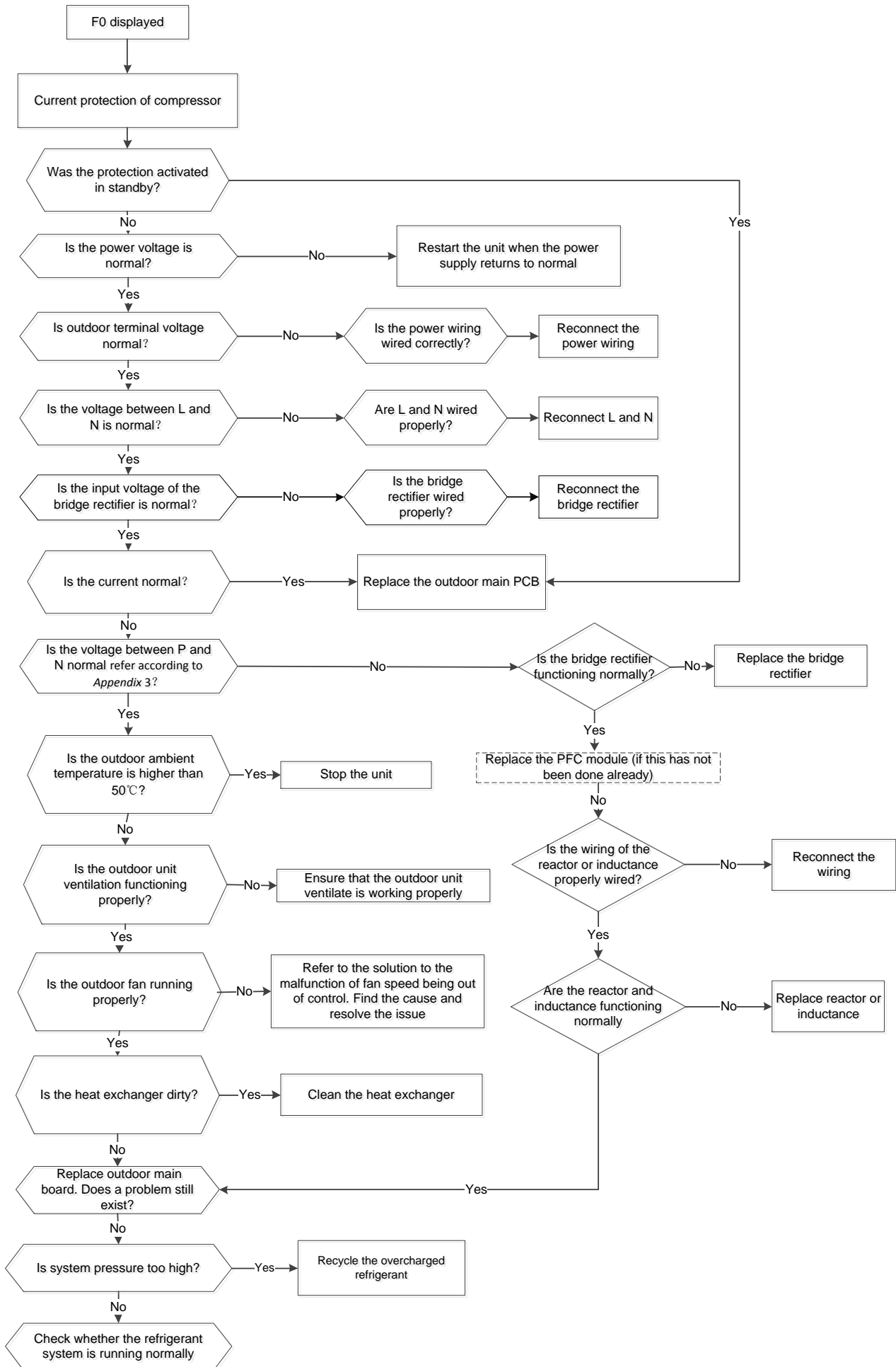

2.4.4.6. F1, F2, F3 Malfunction

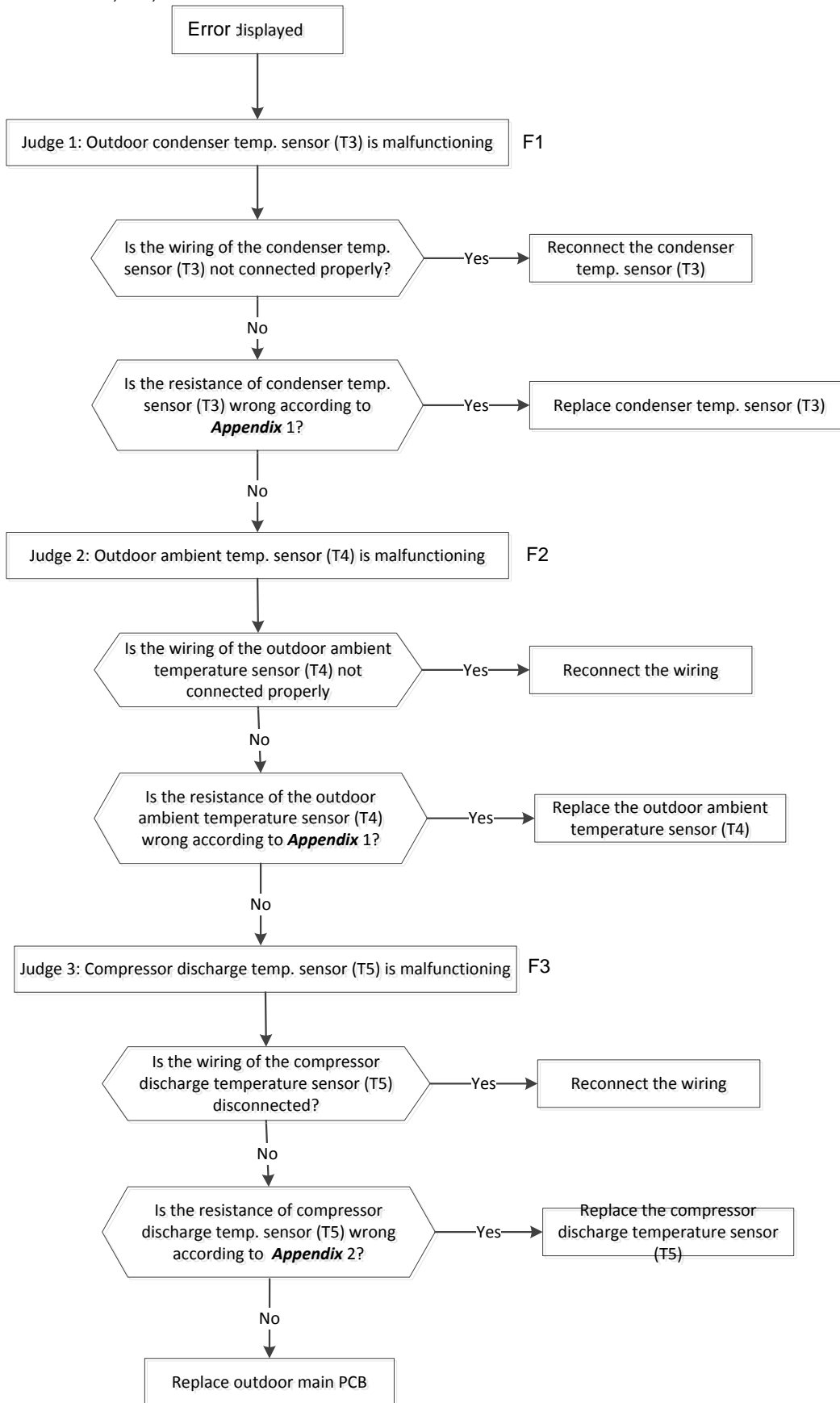

2.4.4.7. F4 Malfunction

Malfunction conditions	Main PCB chip does not receive feedback from EEPROM chip
Possible causes	<ul style="list-style-type: none"> ● Installation mistakes ● Faulty PCB

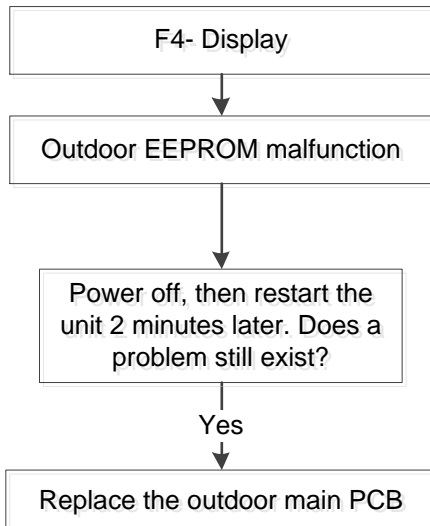

EEPROM: An electrically erasable programmable read-only memory whose contents can be erased and reprogrammed using a pulsed voltage.

2.4.4.8. F5 Malfunction

The same as E3 in indoor unit.

2.4.4.9. P0 Malfunction

Malfunction conditions	When the voltage signal to IPM sends to compressor drive chip is not normal, the LED displays “P0” and the unit turns off.
Possible causes	<ul style="list-style-type: none">● Wiring mistakes● Faulty IPM board● Faulty outdoor fan assembly● Compressor malfunction● Faulty outdoor PCB

First, test the resistance between every two ports of U, V, the W of the IPM and P, N. If any of the results is 0 or close to 0, the IPM is defective. If not, follow the following procedure:



2.4.4.10. P1 malfunction

Malfunction conditions	decision	An abnormal voltage rise or drop is detected by checking the specified voltage detection circuit.
Supposed causes		<ul style="list-style-type: none"> ● Abnormal power supply ● Wiring mistake ● Faulty bridge rectifier ● Faulty IPM board

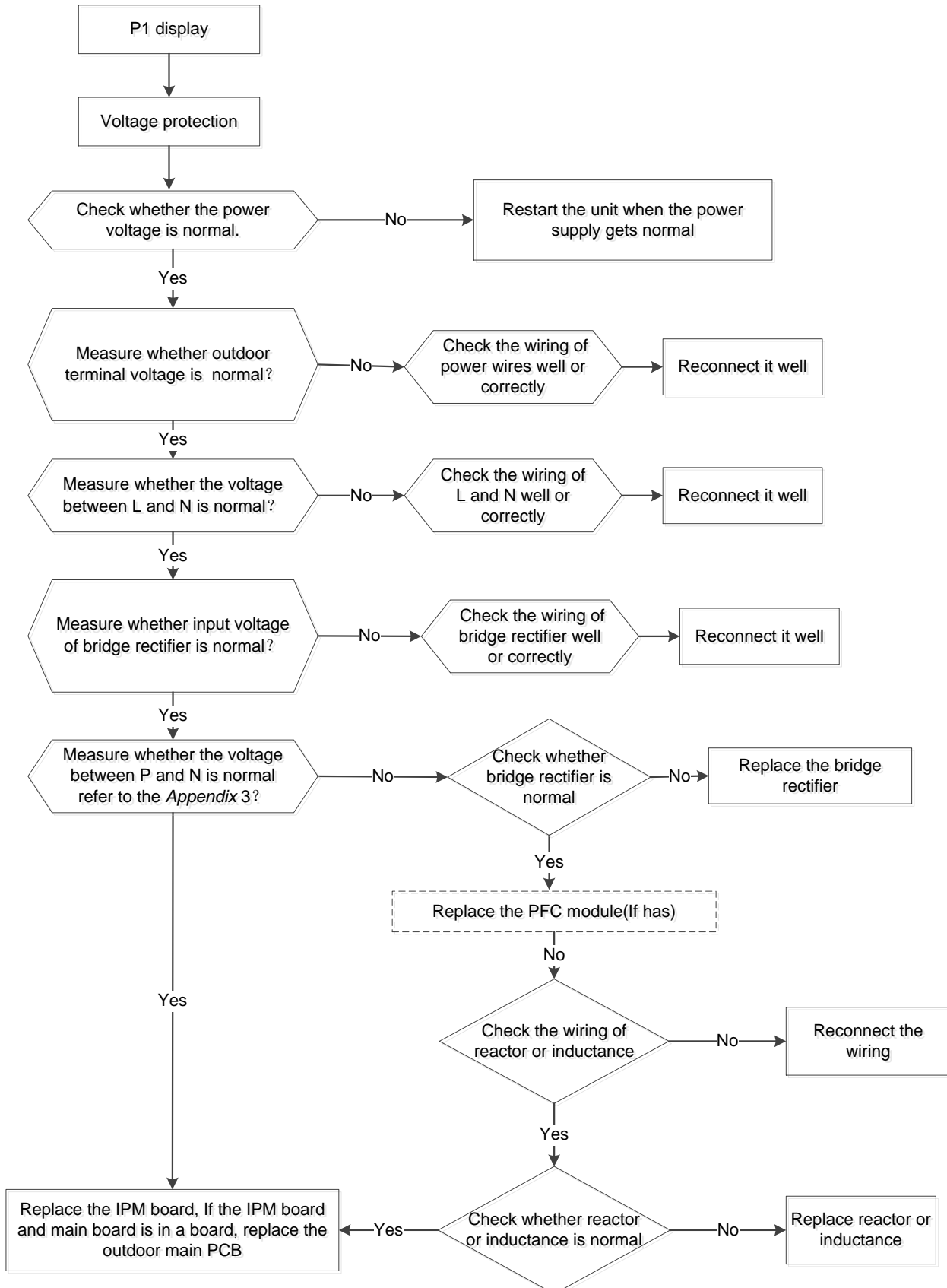

2.4.4.11. P4 Malfunction

The troubleshooting is same as the “IPM module protection”

2.4.4.12. J0 Malfunction

Malfunction conditions	When evaporator coil temperature is more than 60°C, the unit stops. It starts again only when the evaporator coil temperature is less than 54°C
Possible causes	<ul style="list-style-type: none"> • Faulty evaporator coil temperature sensor • Dirty heat exchanger • Faulty fan • Faulty PCB

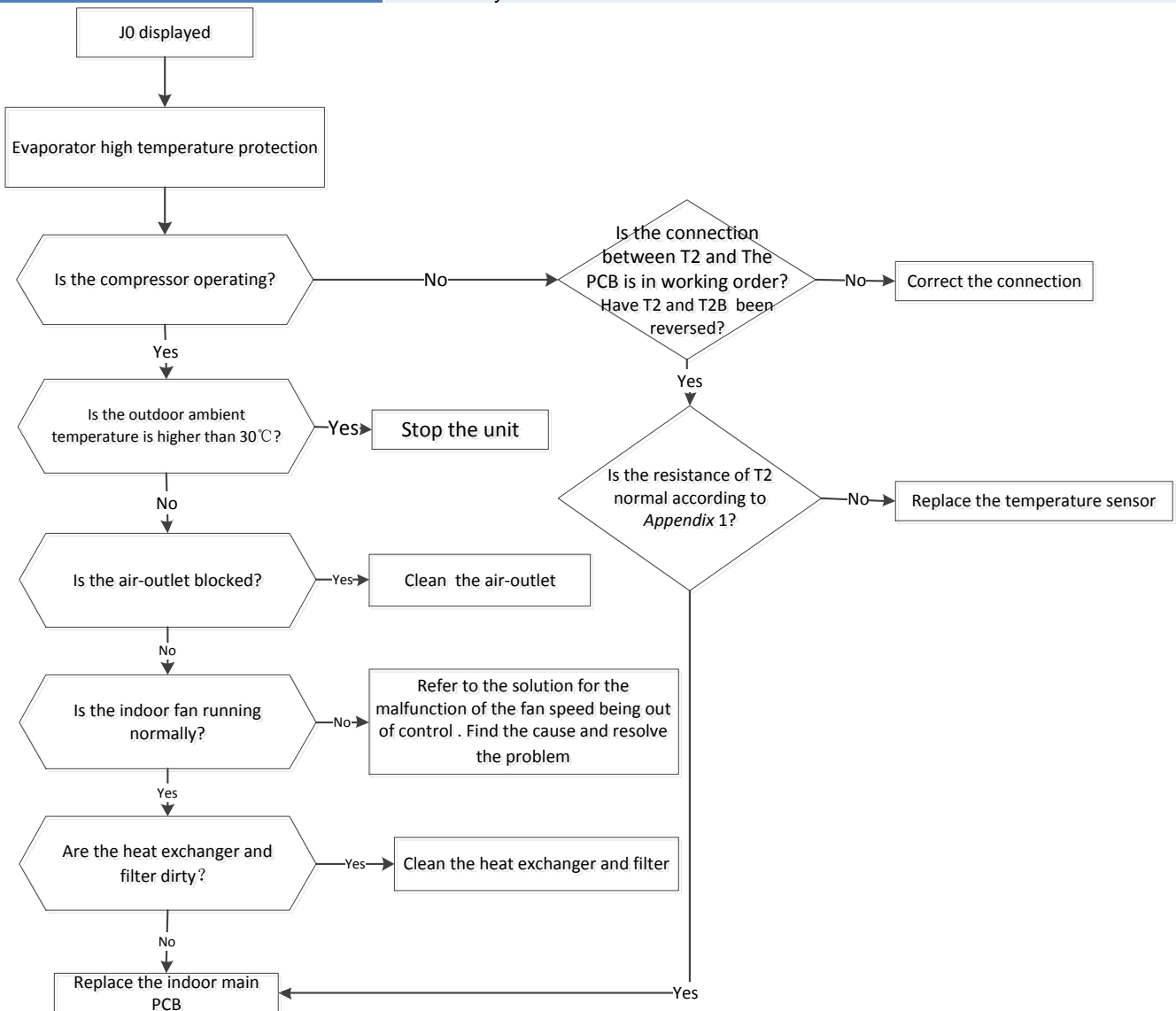

2.4.4.13. J1 Malfunction

Malfunction conditions

When the outdoor pipe temperature is more than 65°C, the unit stops. It starts again only when the outdoor pipe temperature is less than 52°C.

Possible causes

- Faulty condenser temperature sensor
- Dirty heat exchanger
- System leakage or blockages

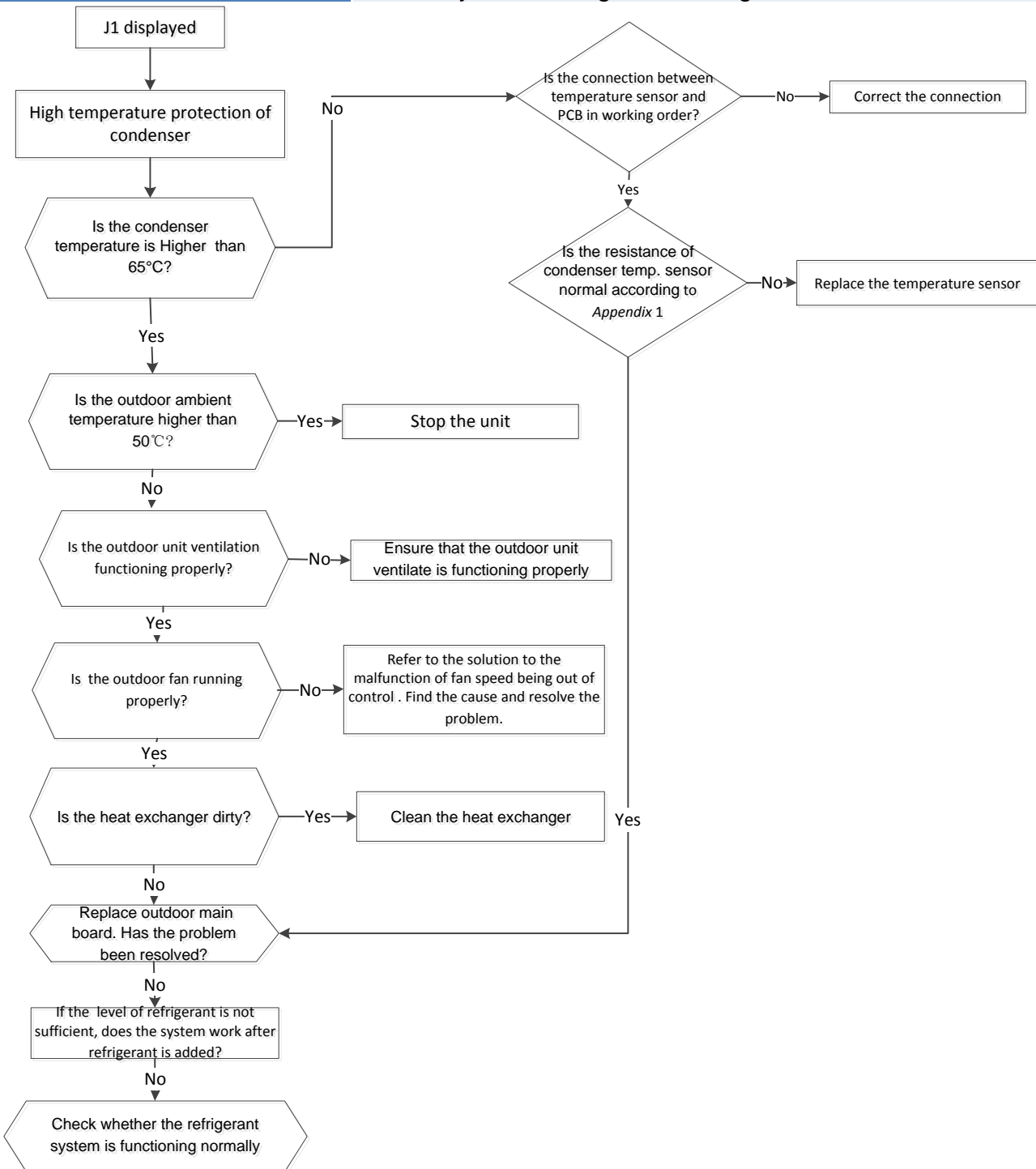

2.4.4.14. J2 Malfunction

Malfunction conditions	When the compressor discharge temperature (T5) is more than 115°C for 10 seconds, the compressor will stop and not restart until T5 is less than 90°C.
Possible causes	<ul style="list-style-type: none"> ● Refrigerant leakage ● Wiring mistake ● Faulty discharge temperature sensor ● Faulty outdoor PCB

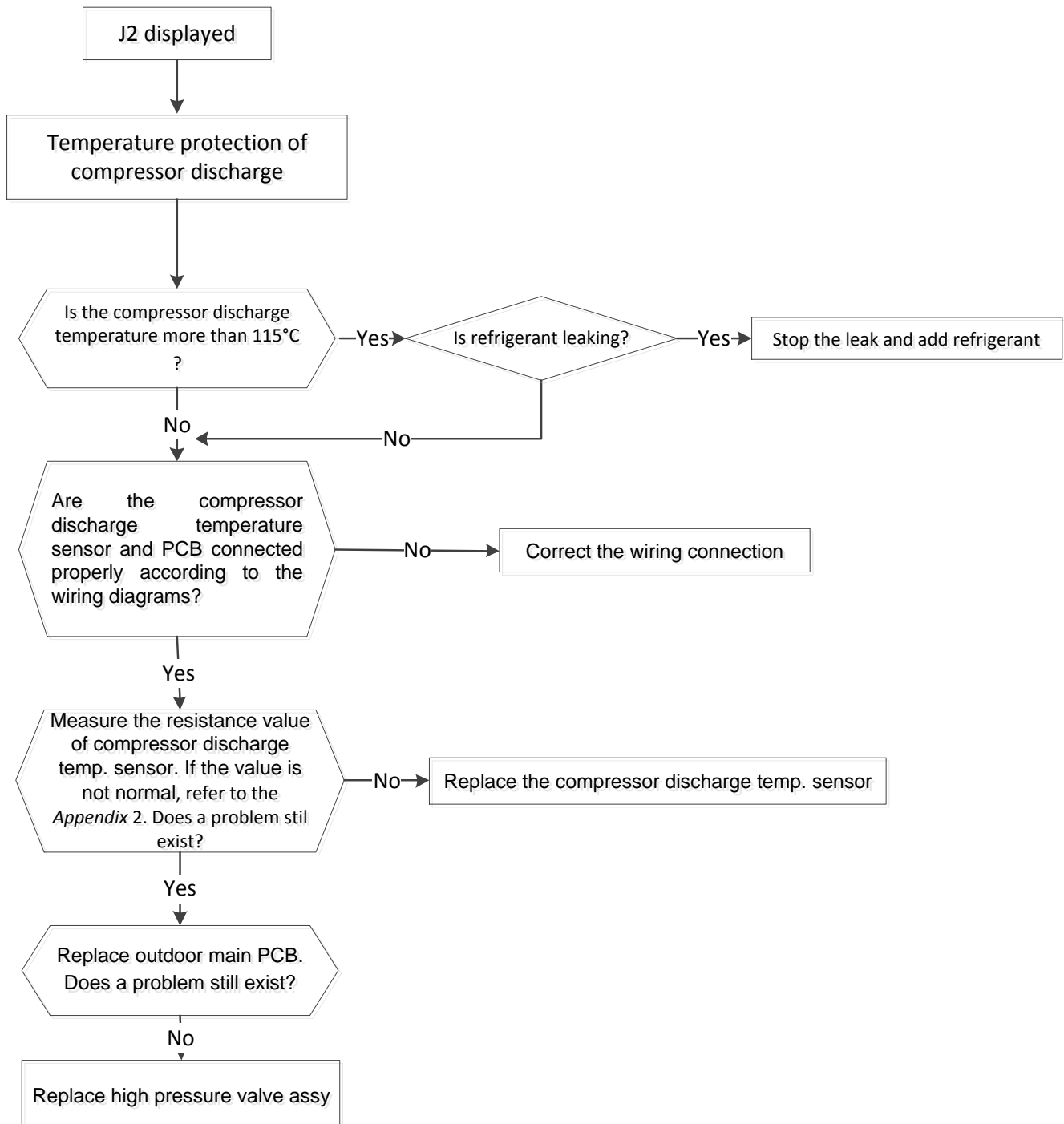

2.4.4.15. J3 Malfunction

Malfunction conditions	When the voltage signal that IPM send to compressor drive chip is abnormal, the display LED will show “P6” and AC will turn off.
Supposed causes	<ul style="list-style-type: none"> ● Wiring mistake ● Faulty IPM board ● Faulty outdoor fan ass’y ● Compressor malfunction ● Faulty outdoor PCB

At first test the resistance between every two ports of U, V, W of IPM and P, N. If any result of them is 0 or close to 0, the IPM is defective. Otherwise, please follow the procedure below:

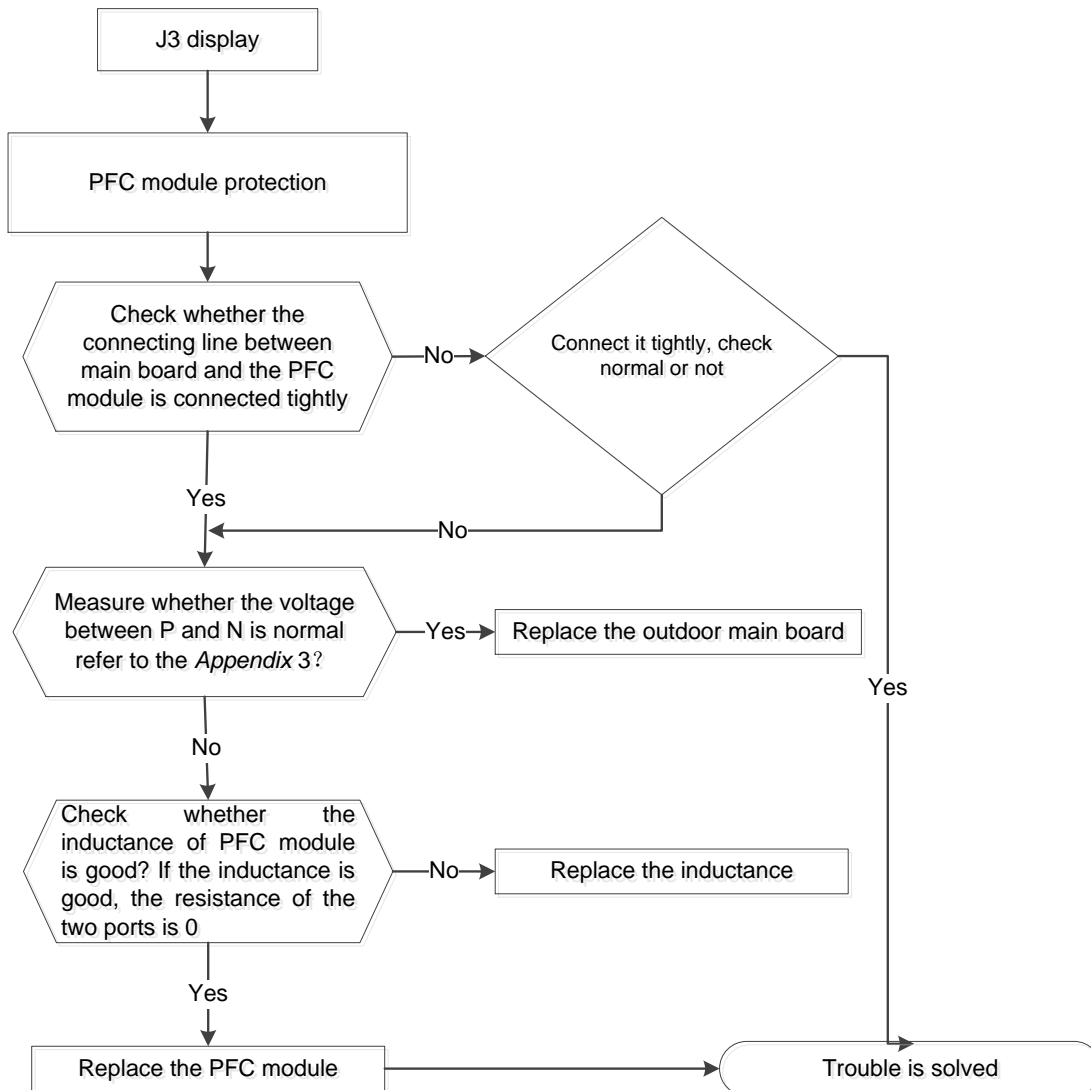

2.4.4.16. J4 Malfunction

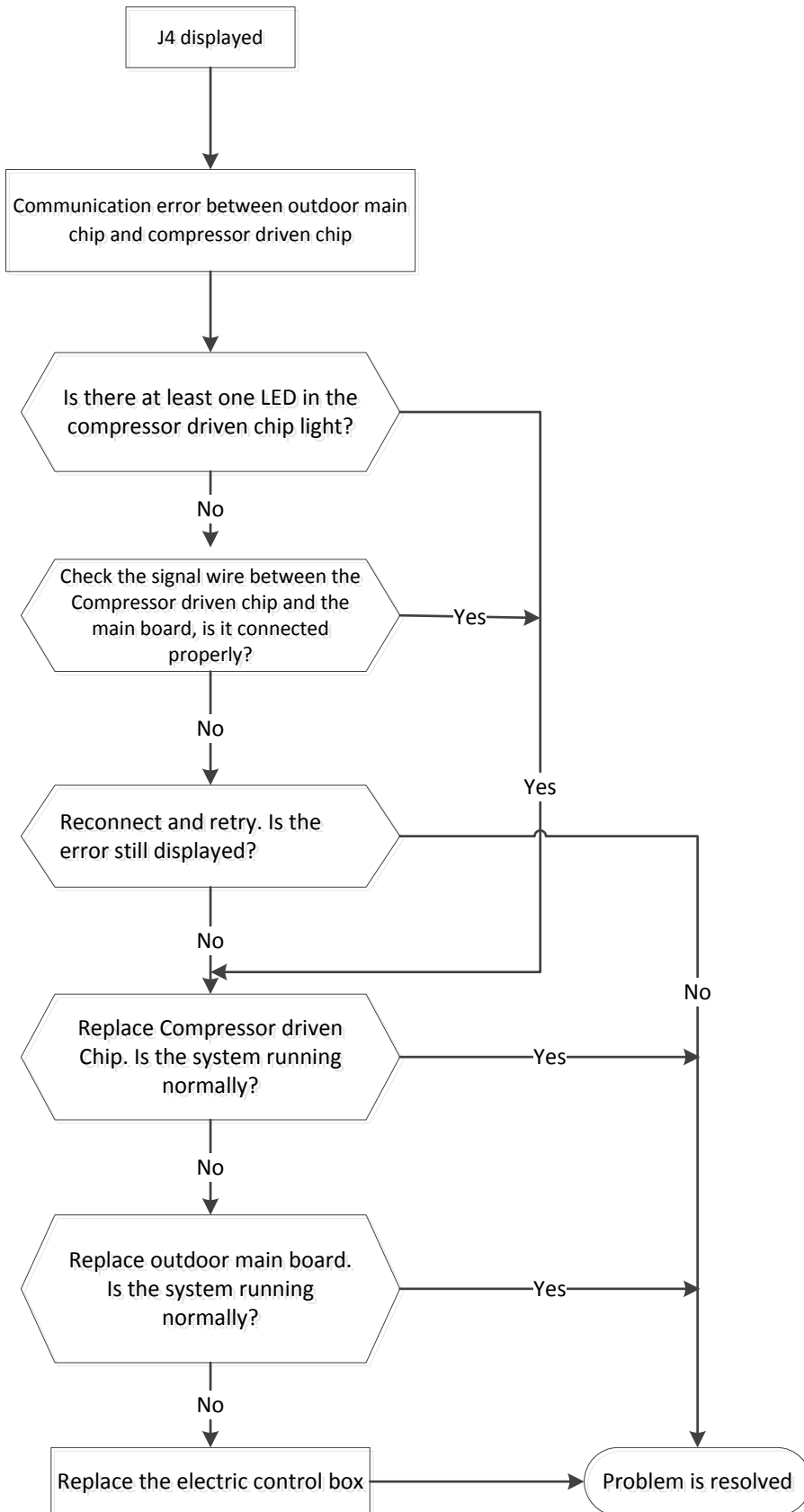

2.4.4.17. J5 Malfunction

Malfunction conditions	If the sampling voltage is not 5V, the LED displays a failure code.
Possible causes	<ul style="list-style-type: none"> ● Wiring mistakes ● Faulty overload protector ● System blockages ● Faulty outdoor PCB

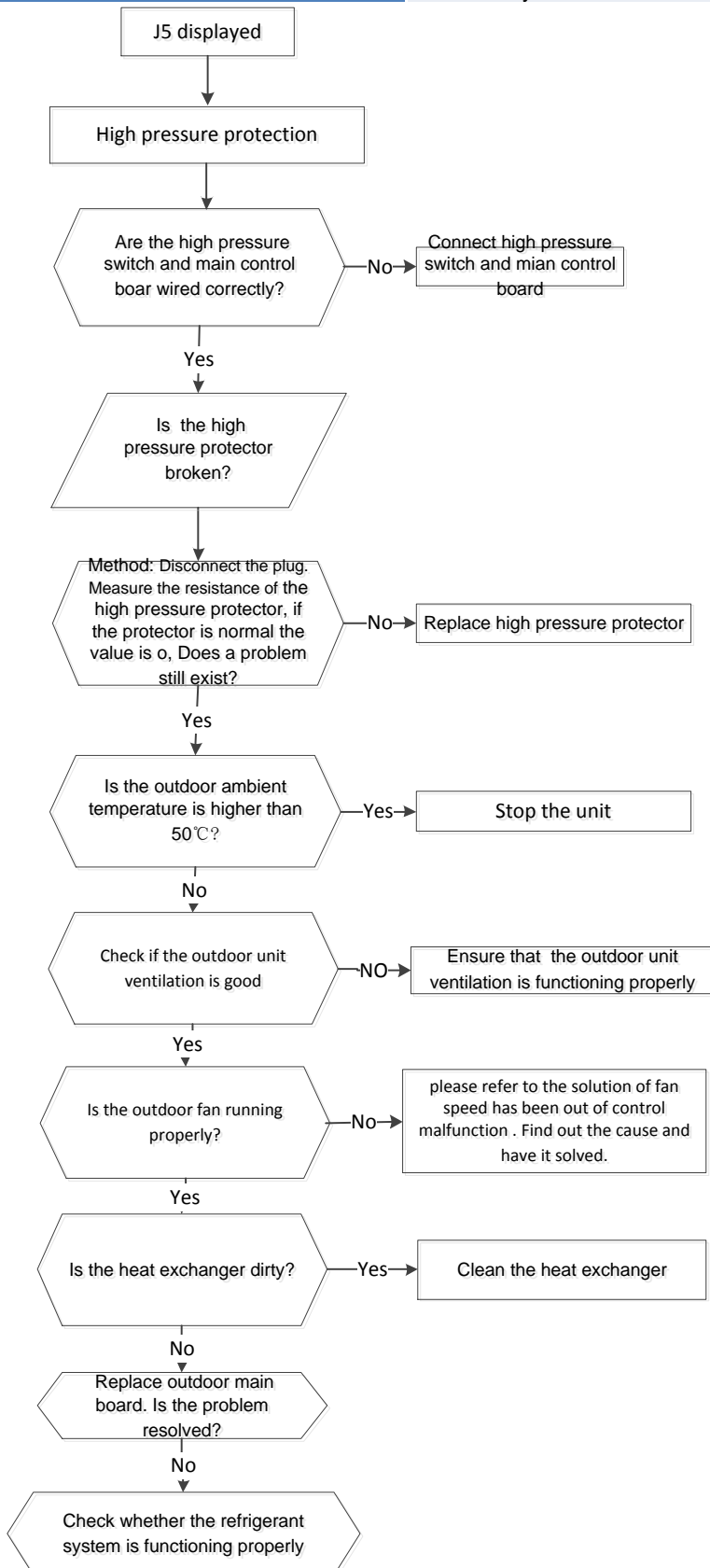

2.4.4.18. P6/J6 Malfunction

Malfunction conditions	If the sampling voltage is not 5V, the LED displays a failure code.
Possible causes	<ul style="list-style-type: none"> ● Wiring mistake ● Faulty over load protector ● System blockages ● Faulty outdoor PCB

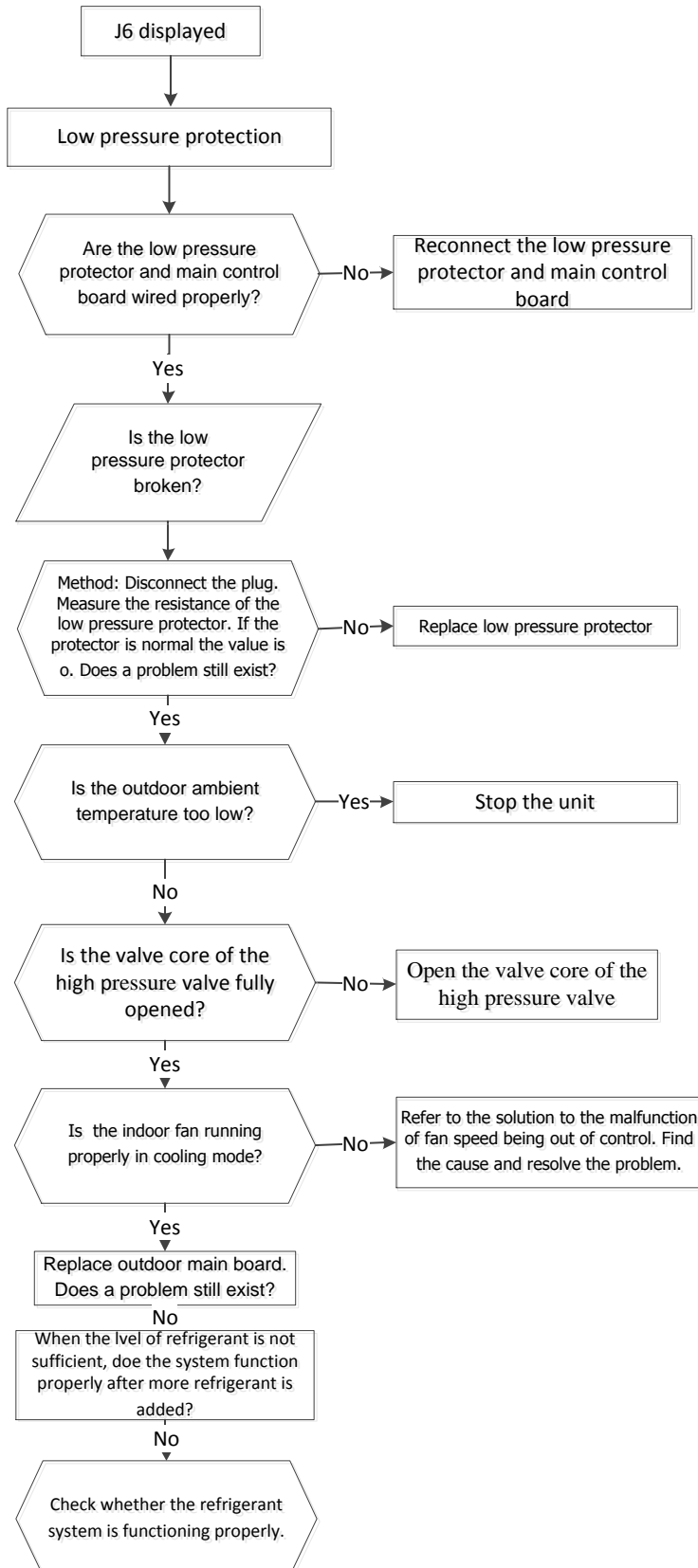

2.4.4.19. J8 malfunction

Malfunction conditions	An abnormal voltage rise or drop is detected by checking the specified voltage detection circuit.
Supposed causes	<ul style="list-style-type: none"> ● Abnormal power supply ● Wiring mistake ● Faulty bridge rectifier ● Faulty IPM board

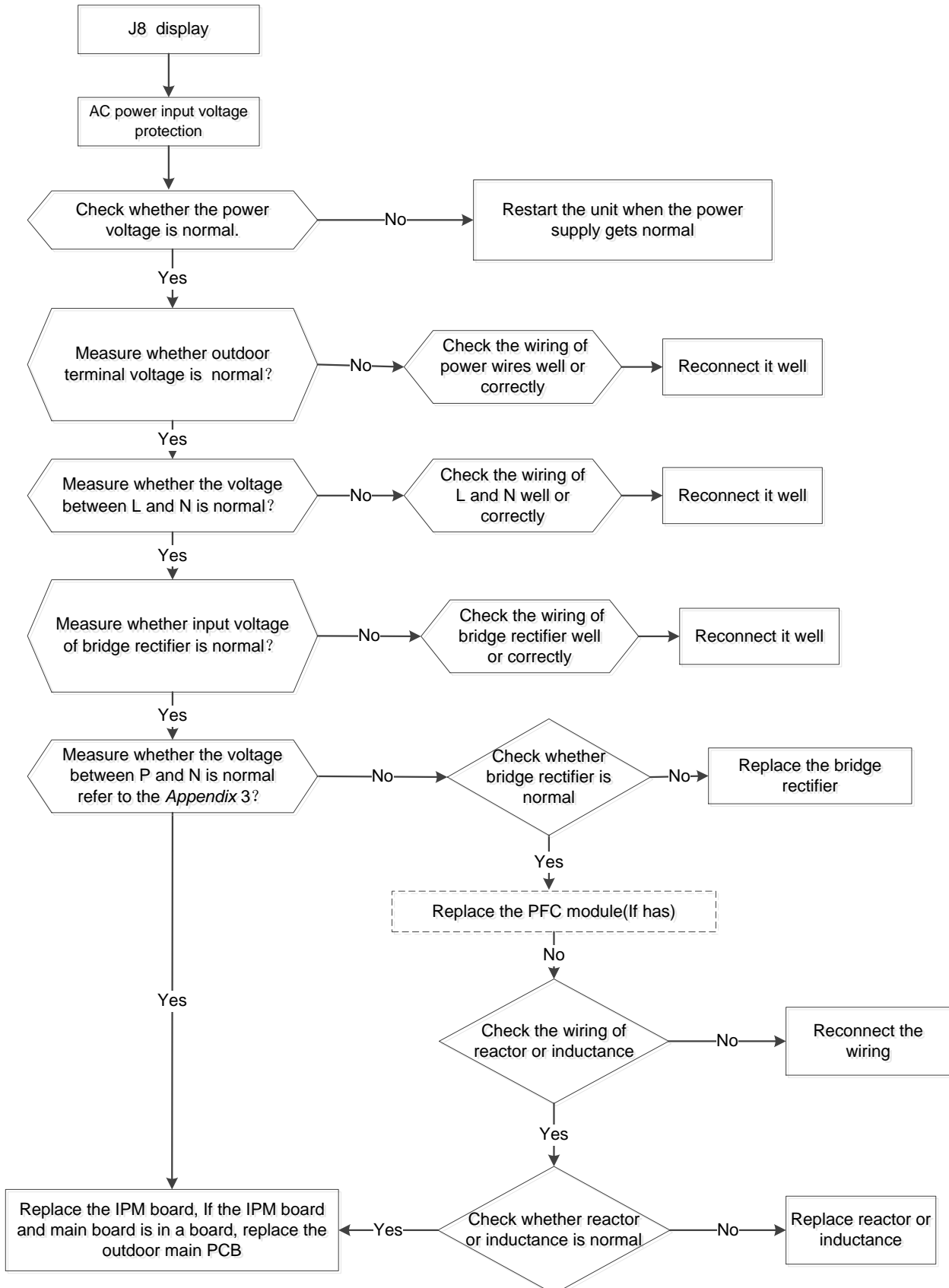

Appendix 1 Temperature Sensor Resistance Value Table (°C--K)

°C	K Ohm	°C	K Ohm	°C	K Ohm	°C	K Ohm
-20	115.266	20	12.6431	60	2.35774	100	0.62973
-19	108.146	21	12.0561	61	2.27249	101	0.61148
-18	101.517	22	11.5000	62	2.19073	102	0.59386
-17	96.3423	23	10.9731	63	2.11241	103	0.57683
-16	89.5865	24	10.4736	64	2.03732	104	0.56038
-15	84.2190	25	10.0000	65	1.96532	105	0.54448
-14	79.3110	26	9.55074	66	1.89627	106	0.52912
-13	74.5360	27	9.12445	67	1.83003	107	0.51426
-12	70.1698	28	8.71983	68	1.76647	108	0.49989
-11	66.0898	29	8.33566	69	1.70547	109	0.48600
-10	62.2756	30	7.97078	70	1.64691	110	0.47256
-9	58.7079	31	7.62411	71	1.59068	111	0.45957
-8	56.3694	32	7.29464	72	1.53668	112	0.44699
-7	52.2438	33	6.98142	73	1.48481	113	0.43482
-6	49.3161	34	6.68355	74	1.43498	114	0.42304
-5	46.5725	35	6.40021	75	1.38703	115	0.41164
-4	44.0000	36	6.13059	76	1.34105	116	0.40060
-3	41.5878	37	5.87359	77	1.29078	117	0.38991
-2	39.8239	38	5.62961	78	1.25423	118	0.37956
-1	37.1988	39	5.39689	79	1.21330	119	0.36954
0	35.2024	40	5.17519	80	1.17393	120	0.35982
1	33.3269	41	4.96392	81	1.13604	121	0.35042
2	31.5635	42	4.76253	82	1.09958	122	0.3413
3	29.9058	43	4.57050	83	1.06448	123	0.33246
4	28.3459	44	4.38736	84	1.03069	124	0.32390
5	26.8778	45	4.21263	85	0.99815	125	0.31559
6	25.4954	46	4.04589	86	0.96681	126	0.30754
7	24.1932	47	3.88673	87	0.93662	127	0.29974
8	22.5662	48	3.73476	88	0.90753	128	0.29216
9	21.8094	49	3.58962	89	0.87950	129	0.28482
10	20.7184	50	3.45097	90	0.85248	130	0.27770
11	19.6891	51	3.31847	91	0.82643	131	0.27078
12	18.7177	52	3.19183	92	0.80132	132	0.26408
13	17.8005	53	3.07075	93	0.77709	133	0.25757
14	16.9341	54	2.95896	94	0.75373	134	0.25125
15	16.1156	55	2.84421	95	0.73119	135	0.24512
16	15.3418	56	2.73823	96	0.70944	136	0.23916
17	14.6181	57	2.63682	97	0.68844	137	0.23338
18	13.9180	58	2.53973	98	0.66818	138	0.22776
19	13.2631	59	2.44677	99	0.64862	139	0.22231

Appendix 2

Unit: °C---K		Discharge temperature sensor table					
-20	542.7	20	68.66	60	13.59	100	3.702
-19	511.9	21	65.62	61	13.11	101	3.595
-18	483	22	62.73	62	12.65	102	3.492
-17	455.9	23	59.98	63	12.21	103	3.392
-16	430.5	24	57.37	64	11.79	104	3.296
-15	406.7	25	54.89	65	11.38	105	3.203
-14	384.3	26	52.53	66	10.99	106	3.113
-13	363.3	27	50.28	67	10.61	107	3.025
-12	343.6	28	48.14	68	10.25	108	2.941
-11	325.1	29	46.11	69	9.902	109	2.86
-10	307.7	30	44.17	70	9.569	110	2.781
-9	291.3	31	42.33	71	9.248	111	2.704
-8	275.9	32	40.57	72	8.94	112	2.63
-7	261.4	33	38.89	73	8.643	113	2.559
-6	247.8	34	37.3	74	8.358	114	2.489
-5	234.9	35	35.78	75	8.084	115	2.422
-4	222.8	36	34.32	76	7.82	116	2.357
-3	211.4	37	32.94	77	7.566	117	2.294
-2	200.7	38	31.62	78	7.321	118	2.233
-1	190.5	39	30.36	79	7.086	119	2.174
0	180.9	40	29.15	80	6.859	120	2.117
1	171.9	41	28	81	6.641	121	2.061
2	163.3	42	26.9	82	6.43	122	2.007
3	155.2	43	25.86	83	6.228	123	1.955
4	147.6	44	24.85	84	6.033	124	1.905
5	140.4	45	23.89	85	5.844	125	1.856
6	133.5	46	22.89	86	5.663	126	1.808
7	127.1	47	22.1	87	5.488	127	1.762
8	121	48	21.26	88	5.32	128	1.717
9	115.2	49	20.46	89	5.157	129	1.674
10	109.8	50	19.69	90	5	130	1.632
11	104.6	51	18.96	91	4.849		
12	99.69	52	18.26	92	4.703		
13	95.05	53	17.58	93	4.562		
14	90.66	54	16.94	94	4.426		
15	86.49	55	16.32	95	4.294	B(25/50)=3950K	
16	82.54	56	15.73	96	4.167		
17	78.79	57	15.16	97	4.045	R(90°C)=5KΩ±3%	
18	75.24	58	14.62	98	3.927		
19	71.86	59	14.09	99	3.812		

Appendix 3

Normal voltage of P and N			
208-240V(1-phase,3-phase)		380-415V(3-phase)	
In standby			
around 310VDC		around 530VDC	
In operation			
With passive PFC module	With partial active PFC module	With fully active PFC module	/
>200VDC	>310VDC	>370VDC	>450VDC

3. Controller

3.1 Wireless Remote Controller (refer the RC manual)

3.2 Wired Remote Controller

3.2.1 KJR-12B



Name and functions of buttons on the wire controller

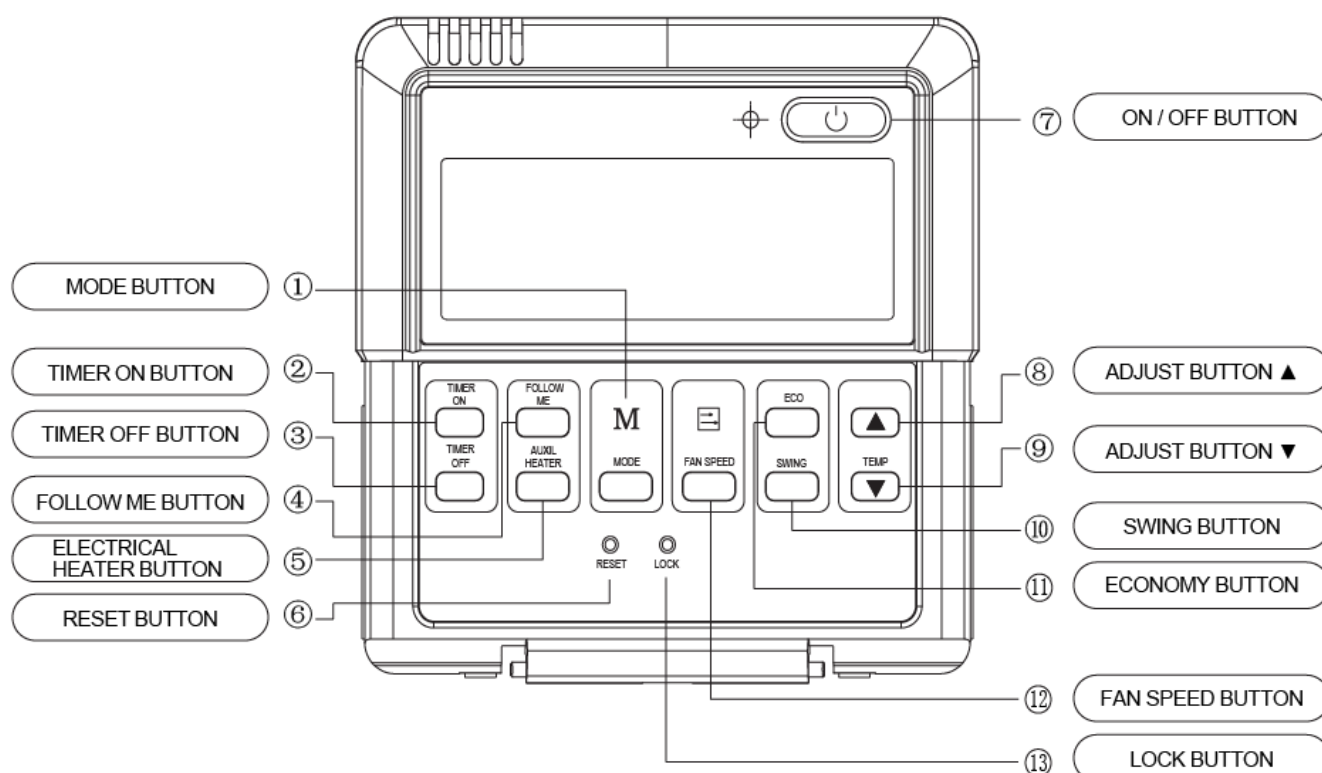

1. Mode button: When press this button, the operation mode change as the following sequence:

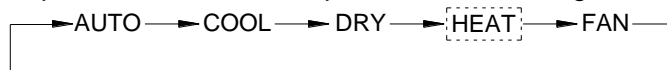

Remark: For the cooling only model, the heating mode is skipped.

2. Timer on button: Press this button, timer on function is active. Then every press, the time increase 0.5h, after 10h, 1h increasement after each press. If cancel this Function, just set it to "0.0"
3. Timer off button: Press this button, timer off function is active. Then every press, the time increase 0.5h, after 10h, 1h increasement after each press. If cancel this function, just set it to "0.0" .
4. Follow me button: When under cool, heat and auto mode, press this button, follow me function is active. Press again, this function is ineffective.
5. Electrical heater button: If press this button in heat mode, electrical heater function become ineffective.
6. Reset button (hidden): Use a 1mm stick to press in the little hole , then the current setting is canceled . The wire controllers enter into original state.
7. ON/OFF button: When in off state, press this button, the indicator is on, the wire controller enter into on state, and send setting information to indoor PCB. When in on state, press this button, the indicator is

- off, and send instruction. If timer on or timer off has been set, it cancel this setting then send instruction to stop the machine.
8. Adjust button: Set indoor temperature up. If press and hold on, it will increase at 1degree per 0.5 second.
 9. Adjust button: Set indoor temperature down. if press and hold on, it will decrease at 1degree per 0.5 Second.
 10. Swing button: First press, start swing function; second press, stop swing. (Match to some model with swing function).
 11. Economy operation button: press this button, the indoor unit operates in economy mode, press again, exit this mode (it may be ineffective for some models)
 12. Fan speed button: press this button consecutively; the fan speed will circle as follow:

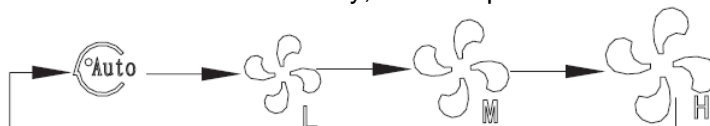

13. Lock button (hidden): When you push the LOCK button, all current settings are locked in and the wire controller does not accept any operation except that of the LOCK button. Use the lock mode when you want to prevent setting from being changed accidentally or play fully. Push the LOCK button again when you want to cancel the LOCK mode.

Name and function of LCD on the wire controller

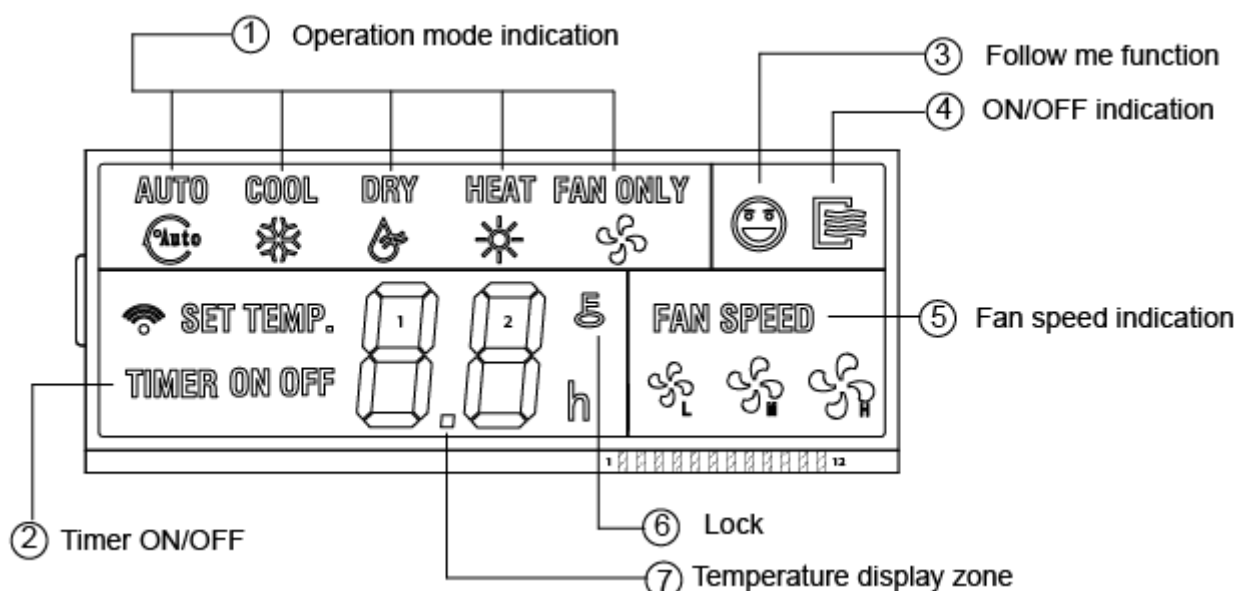

1. Operation mode indication: When press" MODE" button, the following mode can be selected in circle. Auto Cool Dry Heat Fan only Auto.
Auto→ Cool→ Dry →Heat→ Fan only →Auto
For cooling only model, heat mode is skipped.
2. Timer: When adjust setting on time or only on time is set, the "ON" is lighted. When adjust setting off time or only off time is set, the" OFF" is lighted. If on and off timer are both set, the "ON" and "OFF" are both lighted.
3. Follow me function: There is a temperature sensor inside the wire controller, after setting temperature, it will compare the two temperatures, and the space of wire controller will be the same as setting temperature. It is available under cooling, heating, auto mode.
4. ON/OFF indication: When it is on, the icon display, otherwise it is extinguished.
5. Fan speed indication: There are four fan modes: low, middle, high, auto. For some models, no middle fan then the middle fan is seen as high speed.
6. Lock: When the "LOCK" button is pressed, the icon appears and other buttons is unable, press again, the icon disappears.
7. Temperature display zone: Generally it displays setting temperature; it can be adjusted by press temperature button▲and▼ .But in fan mode, no display here.

Remark:

The wired controller will reset to factory setting with auto mode, auto fan and 24°C setting temperature when the air conditioner restarts after power failure.

And this may cause inconsistent displays on the wired controller and on the air conditioner. You need to readjust the running status through the wired controller.

Installation

Wiring Principle Sketch:

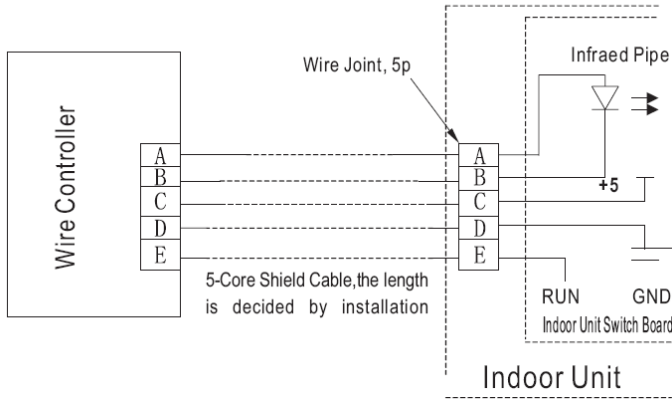
**Installation Notice:**

When the air conditioner needs the constant frequency wire controller, be sure adding a wire joint with 5 terminal named A, B, C, D, E in indoor unit, and fixing an infrared emitter whose anode and cathode connecting with A and B near the receiver in the indoor unit switch board, then connecting the terminal +5v, GND, Run in the switch board to C,D,E respectively.

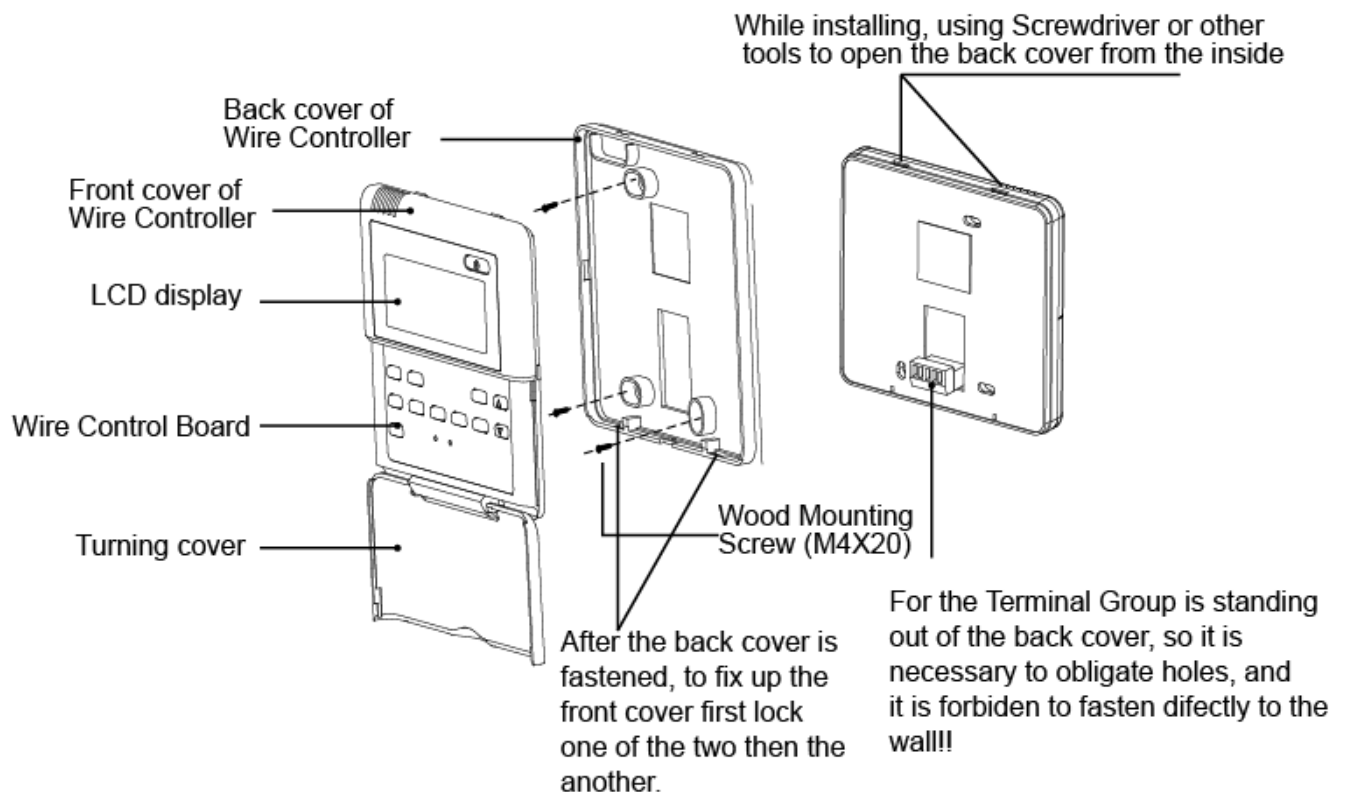
**NOTE**

- The connecting wire should be a little longer as to take away the switch board easily for maintenance.
- The connecting wire should be a little longer as to take away the controller easily for maintenance.

3.2.2 KJR-120C1/BTF-E



Name and functions of buttons on the wire controller

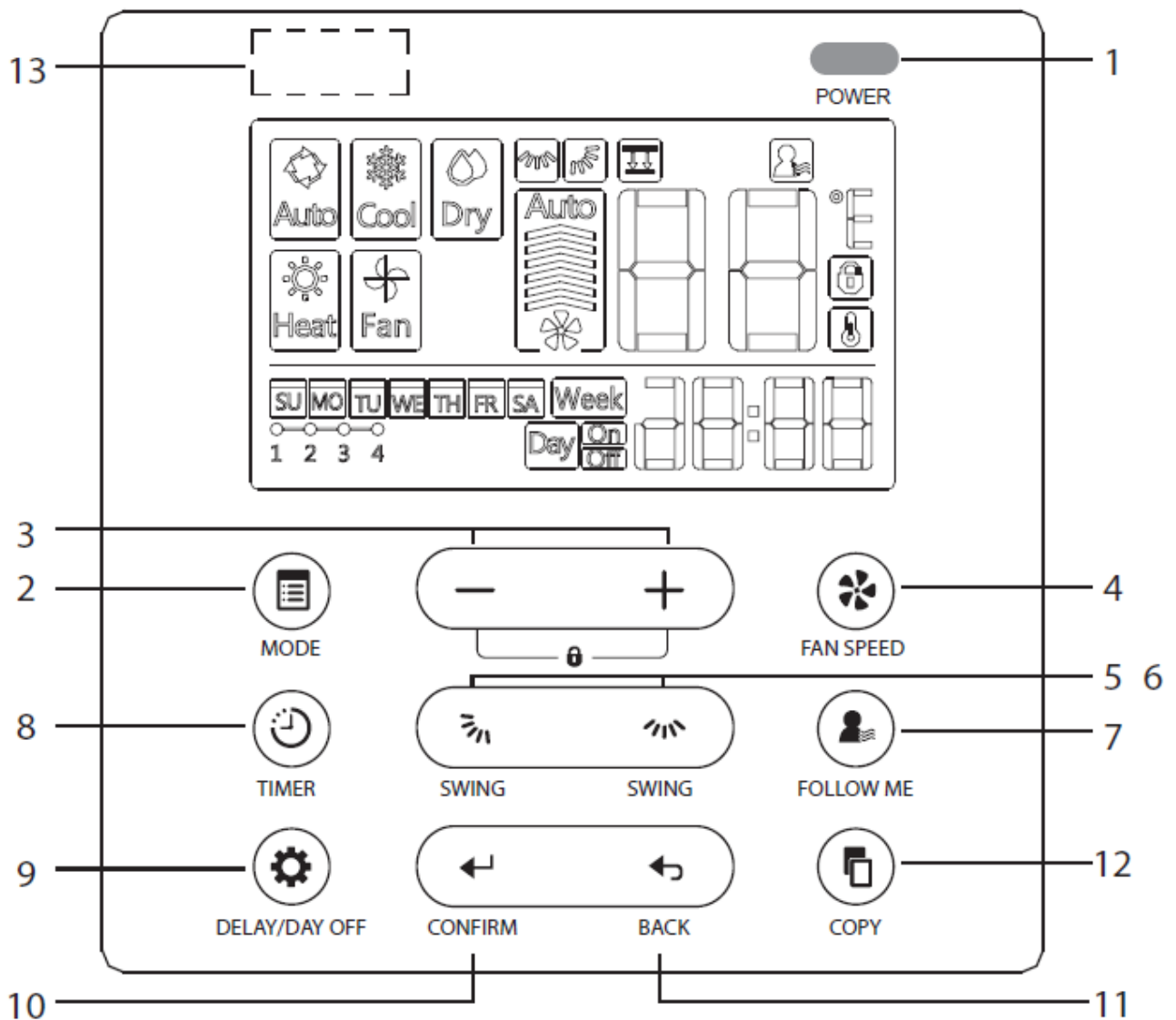

1. Power button: When in off state, short press this button, the operation lamp lights brightly. When in on state, short press this button, the operation lamp does not light. If timer on or timer off has been set, it will not cancel this setting.

When in on state, long press this button 2s or more, the wire controller enters into off state. If timer on, timer off or weekly timer has been set, it will cancel this setting, related indicator is off.

2. Mode button: When press this button, the operation mode changes as the following sequence:

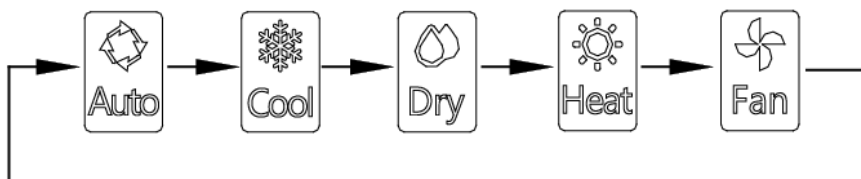

Remark: For the cooling only model, the heating mode is skipped.

3. Adjust button(+,-): Press the button “+” or “-” to set indoor temperature, Indoor Setting Temperature Range : 17~30°C (62~86°F/62~88°F (Depending on models..
4. Fan speed button: press this button consecutively; the fan speed will circle as follow:

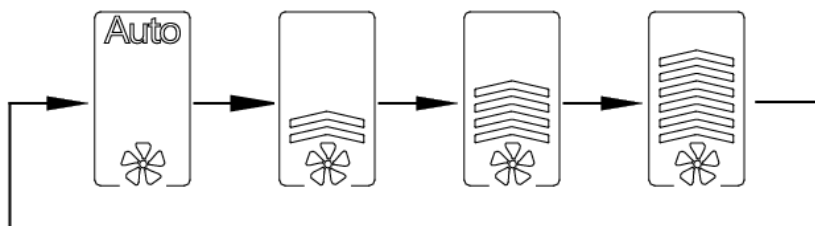

Remark: This button is unavailable when in the mode of Auto or Dry

- 5,6. Swing button: First press, start swing function; second press, stop swing. (Match to some model with swing function).

7. Follow me button: When under cool, heat and auto mode, press this button, follow me function is active. Press again, this function is ineffective.

8. Timer button: Long press this button for 2s, enter week and clock time setting. Short press this button, select timer mode as below:

Weekly timer → On timer → Off timer → On and off timer → No timer → Weekly timer → On timer →

9. Delay/Day off button: During the weekly timer, press the DAY OFF button to set the DAY OFF. The DAY OFF setting is cancelled automatically after the set day has passed.

During the weekly timer, pressing the DELAY button once, display “0h”, Press this button twice, display “1h”, and wait 3 seconds to confirm. It means the unit will override 1 hours; Press this button three times, display “2h” and wait 3 seconds to confirm. It means the unit will override 2 hours.

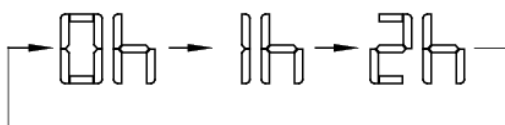

10. Confirm button: Press the CONFIRM button to confirm the settings..
11. Back button: During the weekly timer, press the BACK button to back to last setting until quit the weekly timer and save changed state automatically...
12. Copy button: During the weekly timer, press the COPY button, copy one day's setting to the other day.

Name and function of LCD on the wire controller

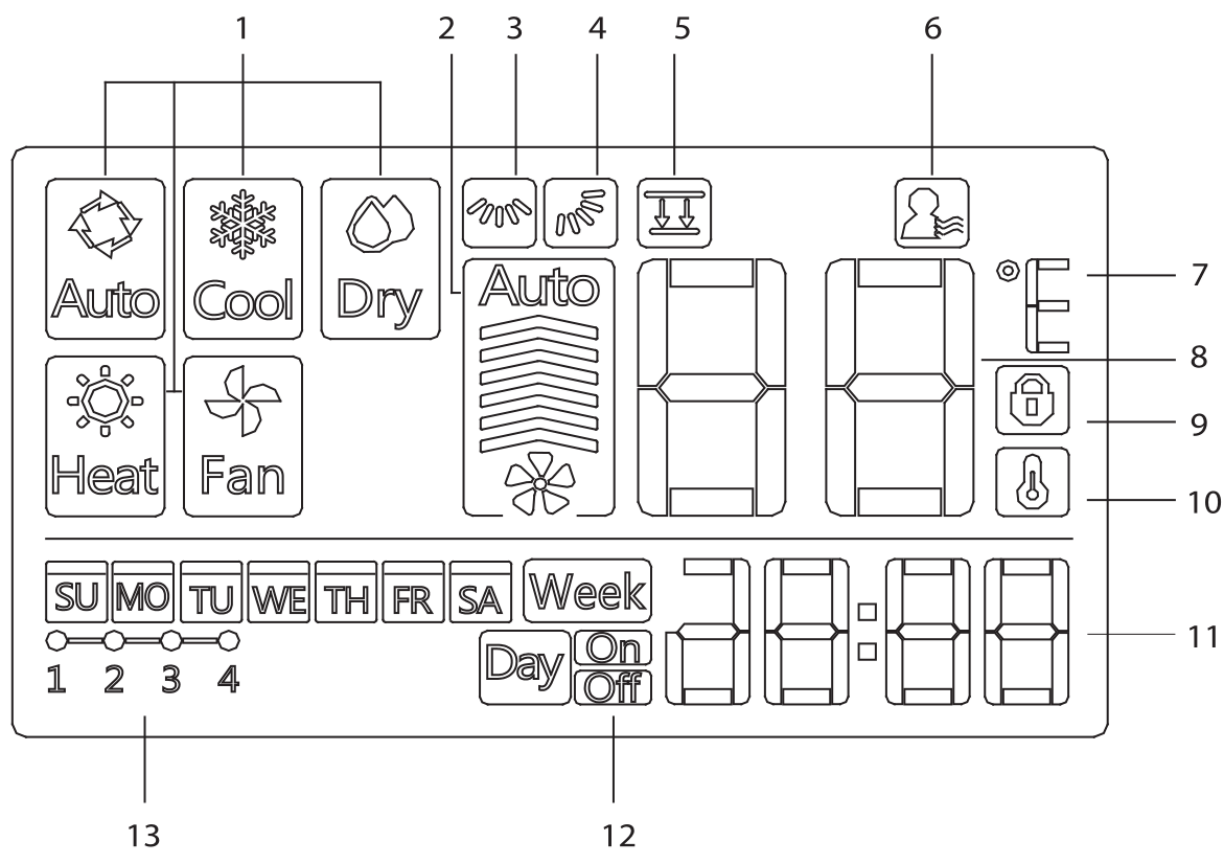

- | | |
|---------------------------------|--------------------------------|
| 1 Operation mode indication | 8 Temperature display |
| 2 Fan speed indication | 9 Lock indication |
| 3 Left-right swing indication | 10 Room temperature indication |
| 4 Up-down swing indication | 11 Clock display |
| 5 Faceplate function indication | 12 On/Off timer |
| 6 Follow me function indication | 13 Timer display |
| 7 C° / F° indication | |

Installation

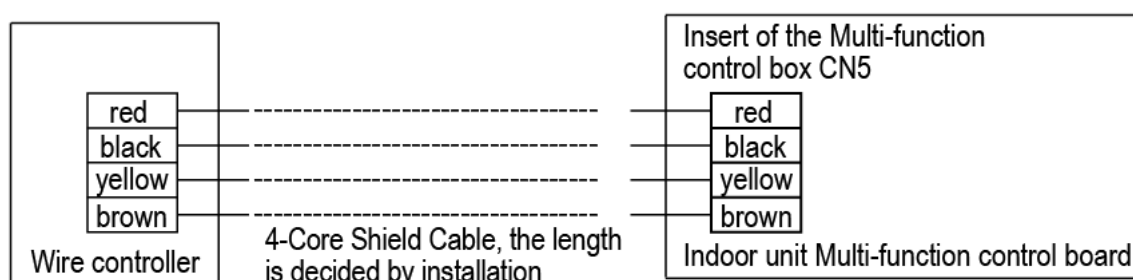

1. Connect the female joint of wires group from the mainboard with the male joint of connective wires group.
2. Please connect the other side of connective wires group with the male joint of wires group leads from wire controller

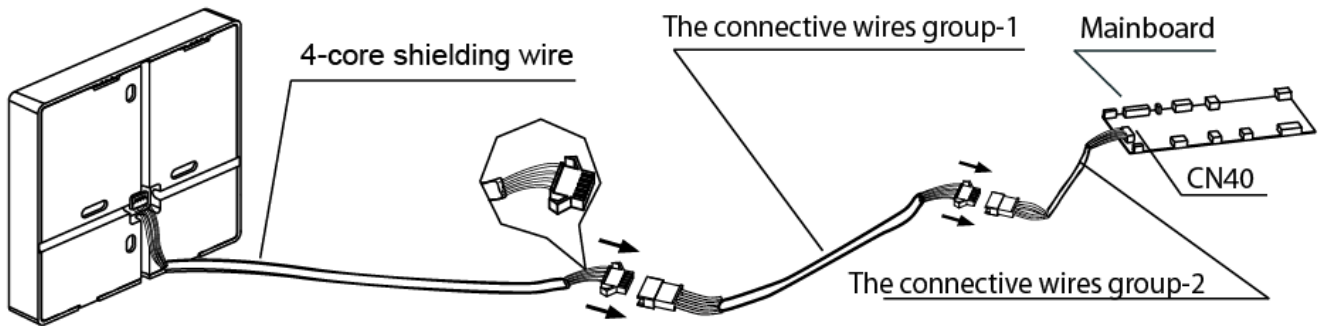

3. Insert a slot screwdriver into the slots in the lower part of the wire controller (2 places), and remove the upper part of the wire controller.

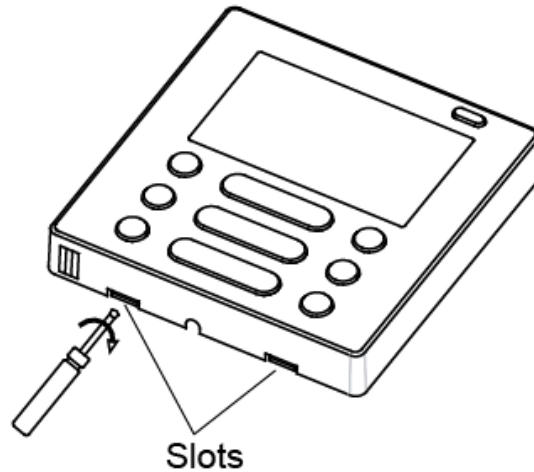

4. Fasten the back plate of the wire controller

4.4 For exposed mounting, fasten the back plate on the wall with the 3 screws (M4×20) and plugs.

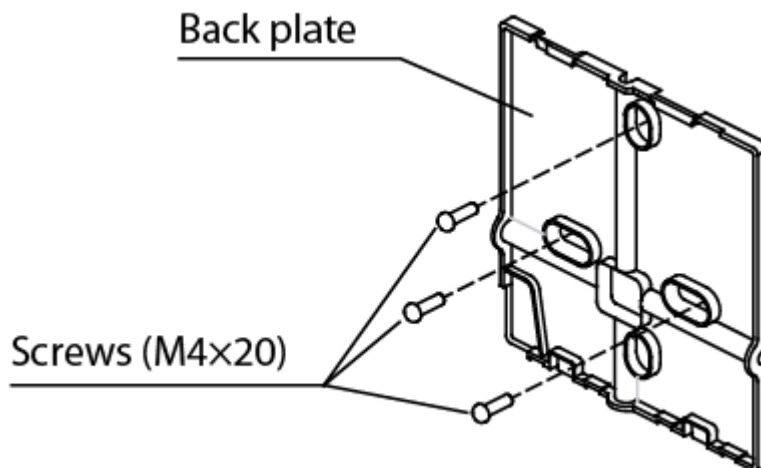

4.5 For flush-mounting, fasten the back plate on the switch box with 2 screws (M4×25) and fasten it on the wall with 1 screw (M4×20).

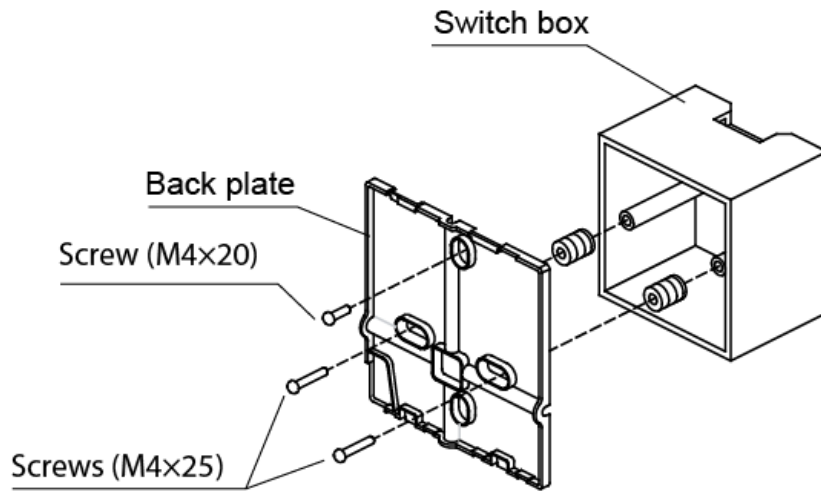

5. Battery installation

4.6 Put the battery into the installationsite and make sure the positive side of the battery is in accordance with the positive side of installationsite.

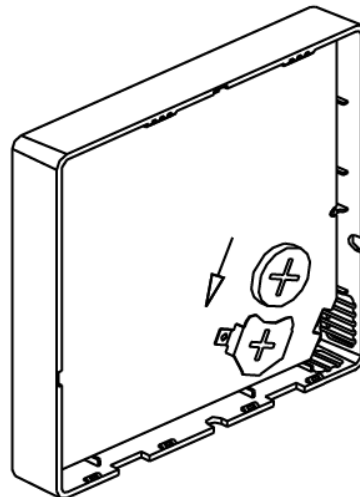

4.7 Please set the time corrected on the first time operation. Batteries in the wire controller can timing under power failure which ensure the time keep right. When the power restores, if the time displayed is not correct, it means the battery is dead and replace the battery.

6. Wiring

A. For exposed mounting, four outletting positions. There are three need cutting.

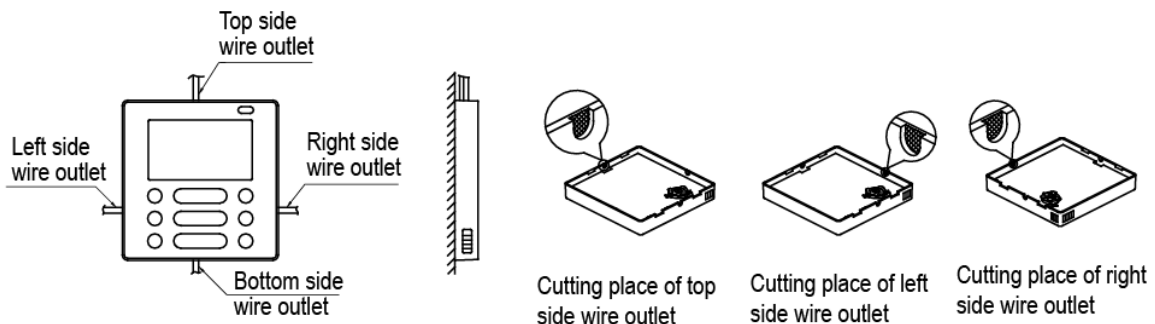

B. Shielded wiring

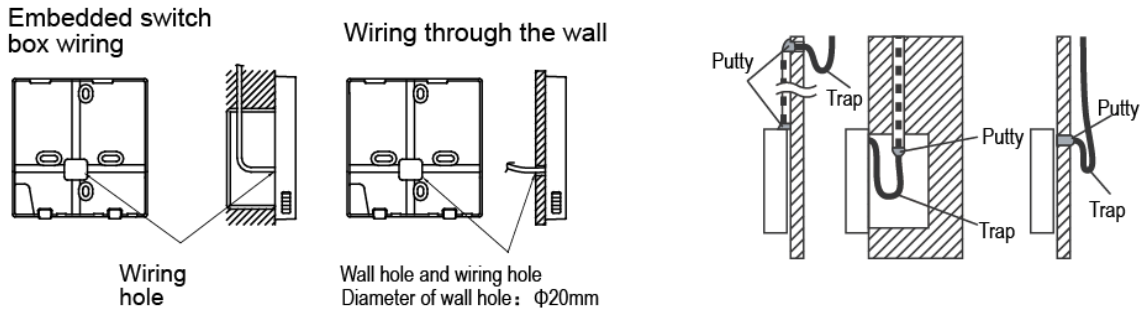

7. Reattach the upper part of the wire controller

After adjusting the upper case and then buckle the upper case; avoid clamping the wiring during installation

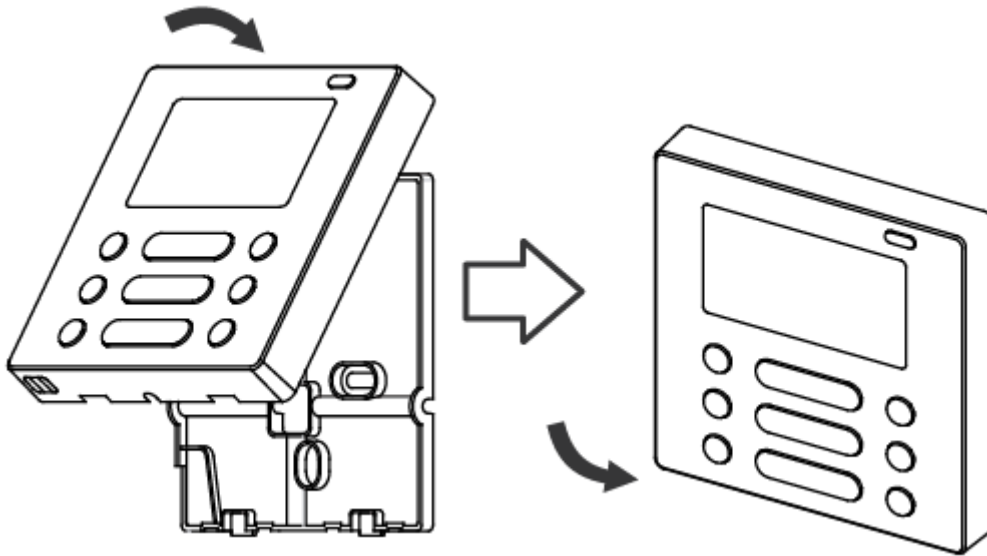

3.2.3 Two-wired non-polarity wired controller(KJR-120G)(Optional)

1.Connection

For Cassette:

The wired controller connects to main control board directly.

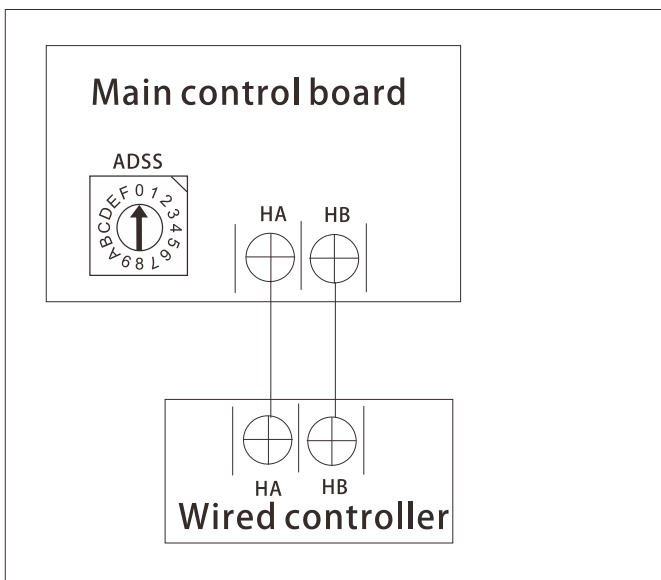

For Duct, Ceiling & floor

The wired controller connects to terminal board, terminal board connects to main control board.

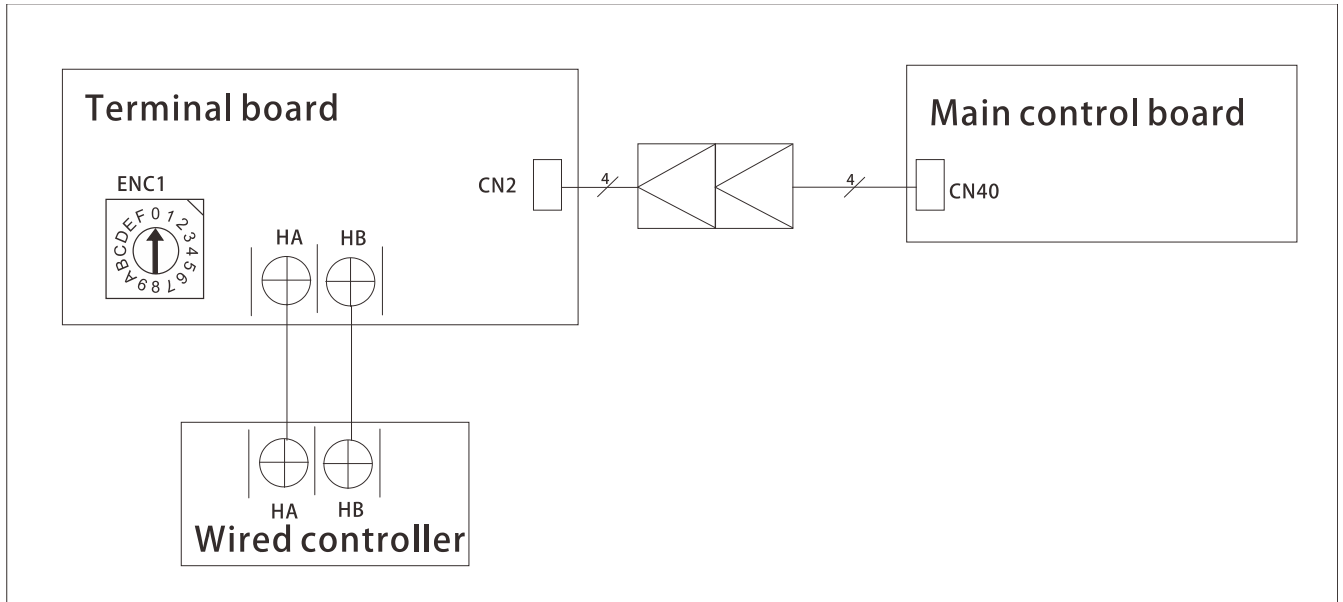

2.Address setting

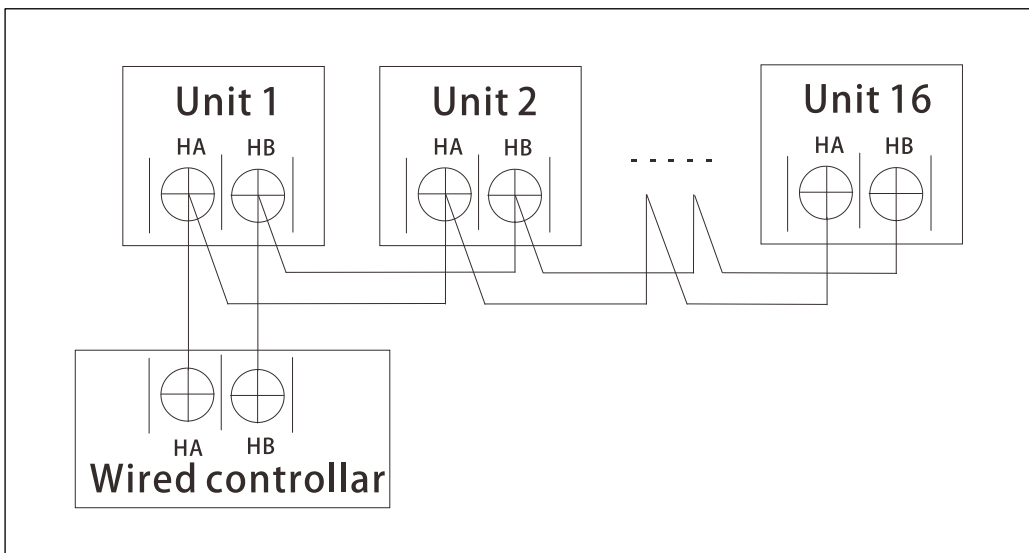

One non-polarity controller can control up to 16 indoor units.

When the non-polarity controller is connected to several units, every air-conditioner in network has only one network address to distinguish each other.

Address code of air-conditioner in LAN is set by code switch ENC1(Duct and Ceiling& Floor) or ADSS(Cassette) of the indoor unit, and the set range is 0-15.

Note: The indoor units are controlled at the same time, not independently. The purpose of setting network address is identify the unit when error occurs.